



User Guide

EVB-ATEK251P4-01

Document Code : 023-102101
Revision No : 05
Revision Date : 07/06/2022

Revisions

Revision No	Revision Date	Revision Reason	Section / Page No
1.0	07.07.2021	Initial Release	
1.1	17.09.2021	Conditions Edited	5/5
1.2	08.01.2022	Format and Content Fixed	
1.3	16.04.2022	Format and Content Fixed	
1.4	06.07.2022	Content Updated	

INDEX

1	GENERAL INFORMATION	3
2	DESIGN INFORMATION.....	4
2.1	SCHEMATIC	4
2.2	BOM	4
3	TYPICAL PERFORMANCE PLOTS.....	5

1 GENERAL INFORMATION

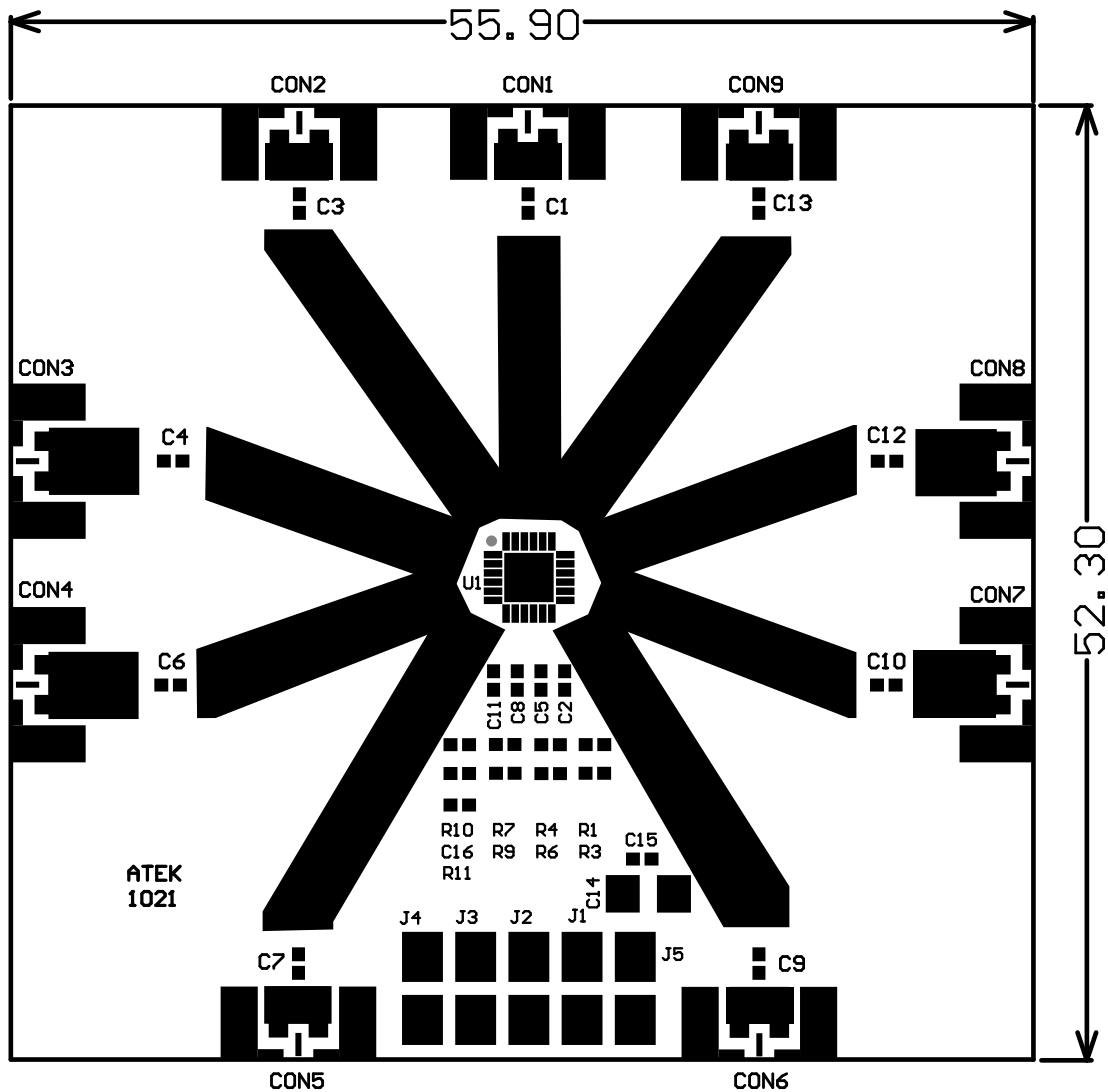

PIN Name	Definition	Comment
CO1	RF IN	SMA Connector
CO2, CO3, CO4, CO5, CO6, CO7, CO8, CO9	RF OUT	SMA Connector
J1 Up, J2 Up, J3 Up, J4 Up, J4 Down, J5 Up	VDD	2.54mm Header
J1 Down	CTRL A	2.54mm Header
J2 Down	CTRL B	2.54mm Header
J3 Down	CTRL C	2.54mm Header
J5 Down	GND	2.54mm Header

Notes:

1. VDD Voltage is detailed in Datasheet.
2. Control Voltages are detailed in Datasheet.
3. The definition of up, down, right, and left is valid for this view of PCB.

2 DESIGN INFORMATION

2.1 SCHEMATIC

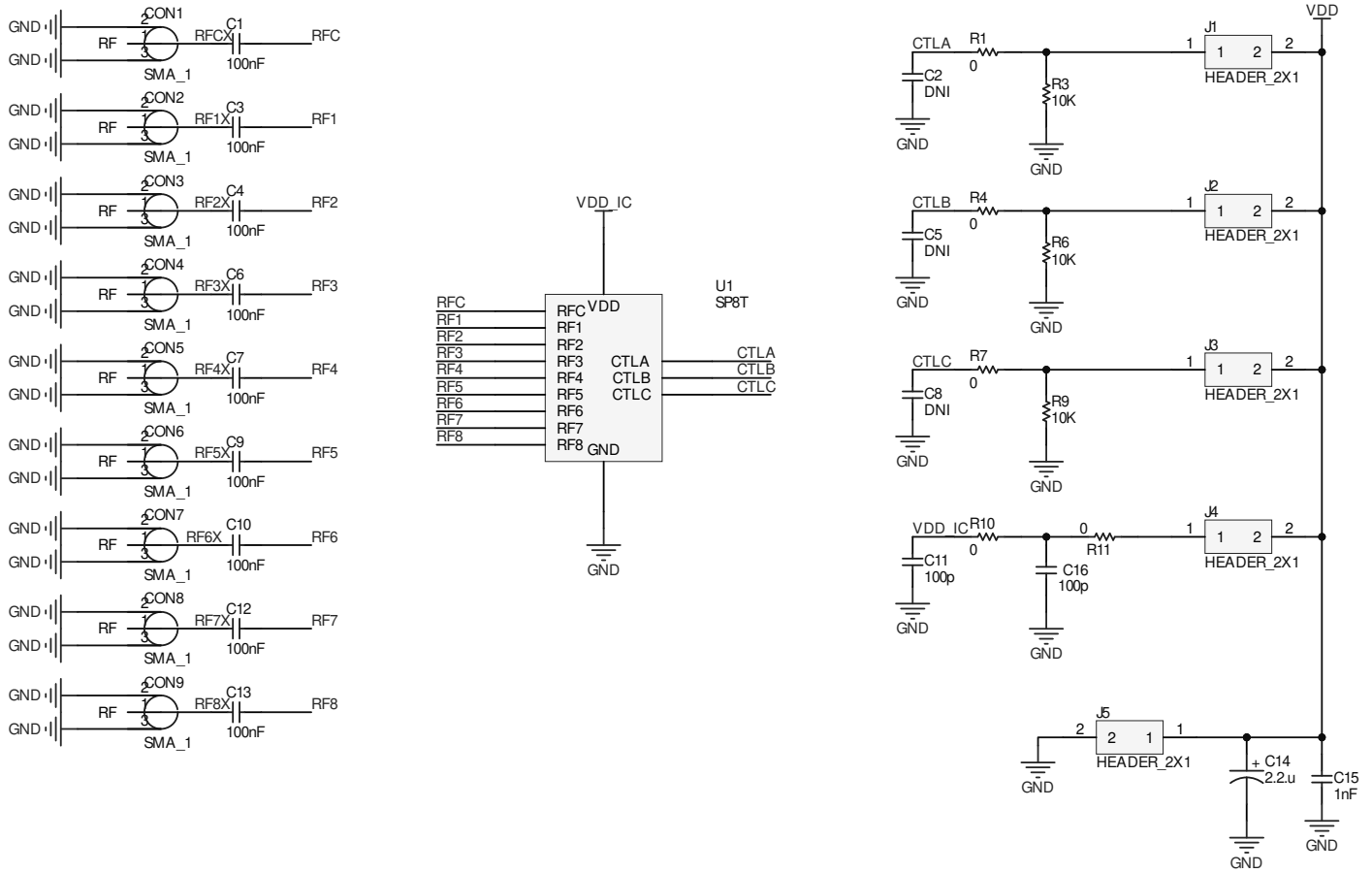

2.2 BOM

Designator	Footprint	Qty	Comment	PN
C1, C3, C4, C6, C7, C9, C10, C12, C13	0402	9	100nF	
C2, C5, C8	0402	3	DNP	
C11, C16	0402	1	100nF	
C14	CASEA	1	2.2uF	
C15	0402	1	1nF	
CON1, CON2, CON3, CON4, CON5, CON6, CON7, CON8, CON9	SMA Connector	9	SMA Connector	
J1, J2, J3, J4, J5	2x1 Header	5	2x1 Header	
R1, R4, R7, R10, R11	0402	5	0R	
R3, R6, R9	0402	3	10k	
U1	ATEKQ4424	1	SP8T	ATEK251P4

3 TYPICAL PERFORMANCE PLOTS

Conditions unless otherwise specified: $V_{CTRL} = 0\text{ V} / 5\text{ V}$, $T = 25\text{ C}$, CW. For details, please refer to the datasheet.

Insertion Loss

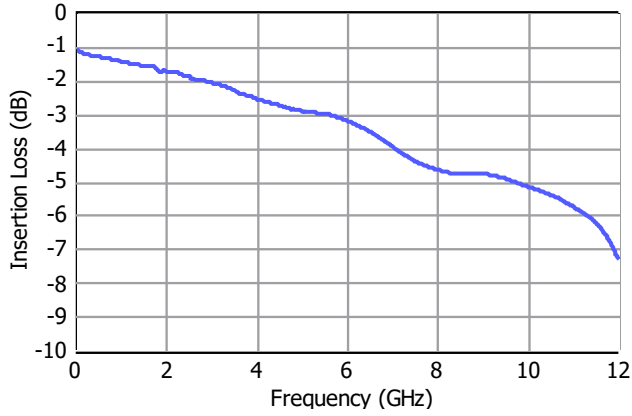

Return Loss

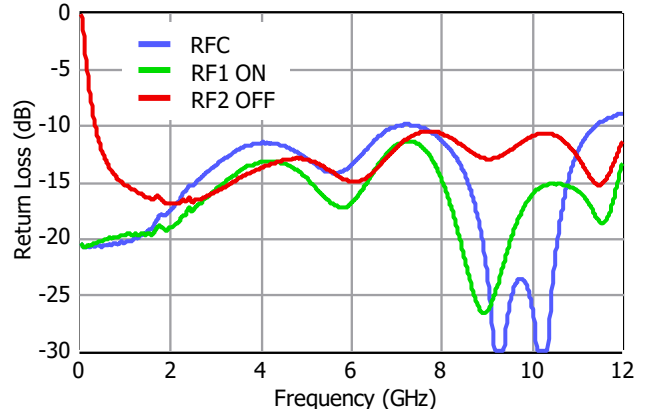

Isolation from RFC to RF2

