

Dc mind Brush motor

Data sheet

89 890 004

Series

89 890

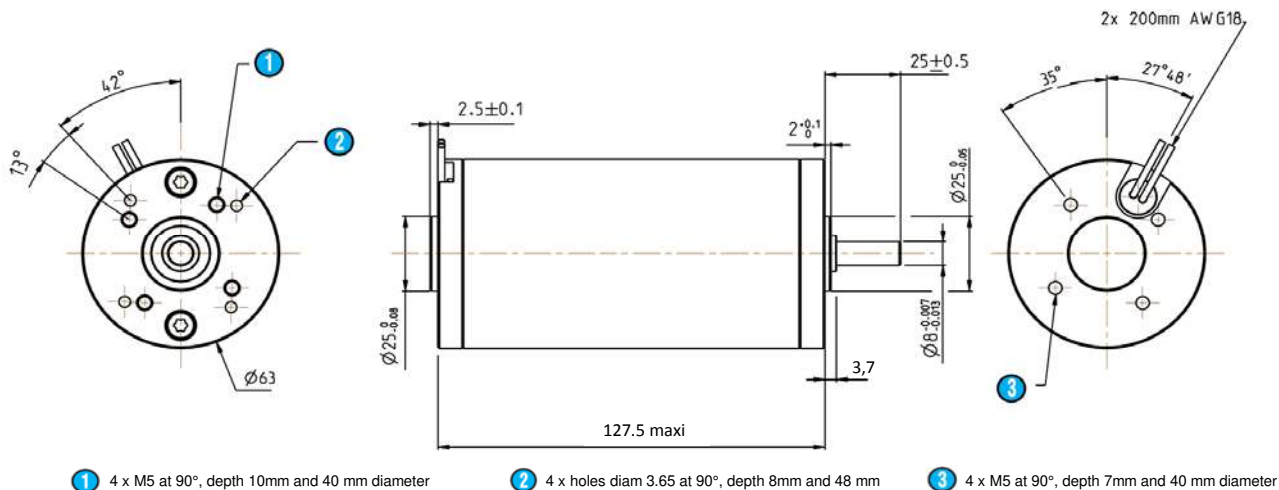

General characteristics

Motor characteristics at (1)		90 Vdc	
At no load - A			
Speed	rpm	3 700	+10%
Current	A	0,09	
EMC (55022)	class	B	
Life (2)	h	20 000	
At max efficiency - B			
Speed	rpm	3 410	+10%
Torque (4)	mNm	218	
Power output	W	78	
Current	A	1,03	
Efficiency	%	84	
EMC (55022)	class	B	
Life (2)	h	10 000	
At nominal load - C			
Speed	rpm	3 320	+10%
Torque (4)	mNm	290	
Power output	W	101	
Current	A	1,34	
Efficiency	%	84	
EMC (55022)	class	B	
Life (2)	h	5 000	
Others			
Starting torque	mNm	2 780	
Starting current	A	12,1	
Max. output power	W	269	
Motor parameters (1)			
Allowed speed	rpm	10 000	max
Rated torque	mNm	290	
Electrical time constant	ms	1,6	
Mechanical time constant	ms	9	
Factor torque / speed	mNm/rpm	0,76316	
Dry friction	mNm	10	
Viscous friction	mNm/krpm	2,4	
Rotor inertia	gcm ²	650	
Thermal Resistance	°/W	5	
Stator poles		2	
Collector blades		12	
Cogging torque	mNm	9	
Weight (g)	g	1 600	
Noise level	dBA	35	

Winding parameters (1)			
Torque constant	mNm/A	232,0	+10%
Constant electromotive force	Volts/(rad/s)	0,232	+10%
	V / Krpm	24,29	+10%
Resistance	Ohms	7,4	+10%
Inductance	mH	12	
Start voltage	Volts	0,6	
Current demagnetization	(magnets at 150 ° C)	A	28

Generic parameters			
Motor for direct current supply			✓
Output shaft with ball bearings			✓
Max. Radial force (20mm from front face)	N	150	
Max. axial force(5)	N	100	
Temperature range	CEI60068-2-1/2	°C	-30 / 70
Storage temperature		°C	-40 / 100
Dielectric (1min 2mA 50Hz)	CEI60335	Vdc	500
Motor insulation	CEI60085	class	E (120°C)
Enameled wire insulation		class	F (155°C)
Salt spray	CEI60068-2-58	severity	2
Degree of protection	CEI60529	IP	65
EMC			
Electrostatic Discharge	CEI61000-4-2	level	3
Electrical fast transient / burst test	CEI61000-4-4	level	3
Surge test	CEI61000-4-5	level	2
Without EMC filter			✓

Approvals			
Designed in accordance with UL			1004
ROHS	2002/95/CE		✓
EC			✓

Values without tolerances, are average production values.

(1) Cold motor, 20 ° C ambient temperature
 (2) Continuous cycle, one direction
 (3) Continuously rated torque, zero radial and axial loads
 (4) Max torque for continuous operation at 20 ° C, decrease this value for higher ambient temperature
 (5) Pinion or pulley fitting are done at the Crouzet factory, before final assembly.

Curves

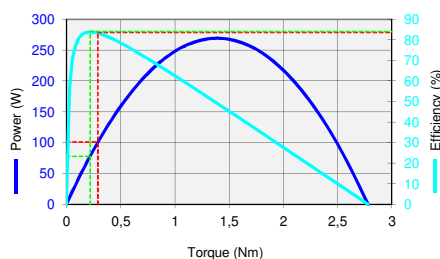
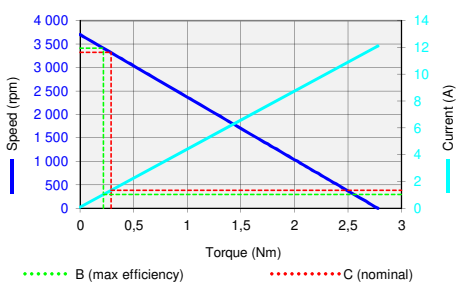

Performance / Motor curves (1)					
Voltage supply		Vdc	90		
		Output data			
		A	B	C	D
Speed	rpm	3 700	3 410	3 320	0
Torque (4)	mNm	0	218	290	2 780
Current	A	0,1	1,0	1,3	12,1
Power output	W	-	78	101	-
Efficiency	%	-	84	84	-

Specifications subject to change without notice. Updated february 29, 2012.