

PRODUCT NUMBER

10127719-00XXLF

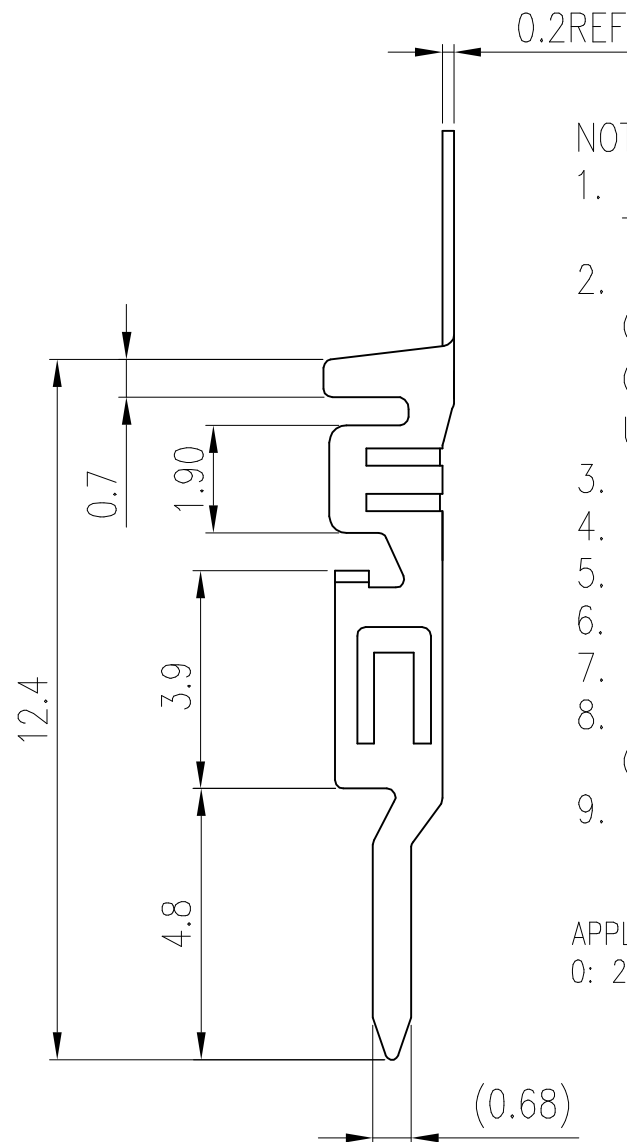
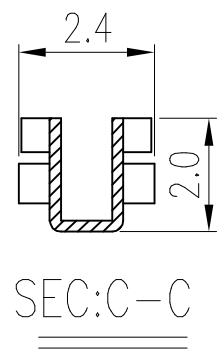
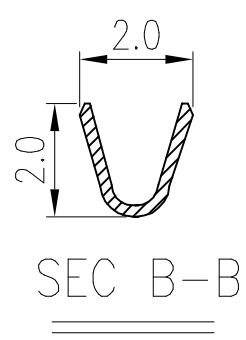
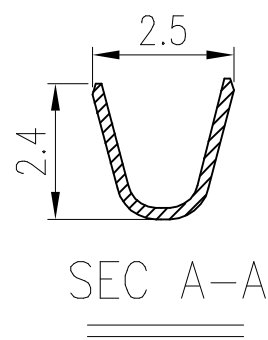
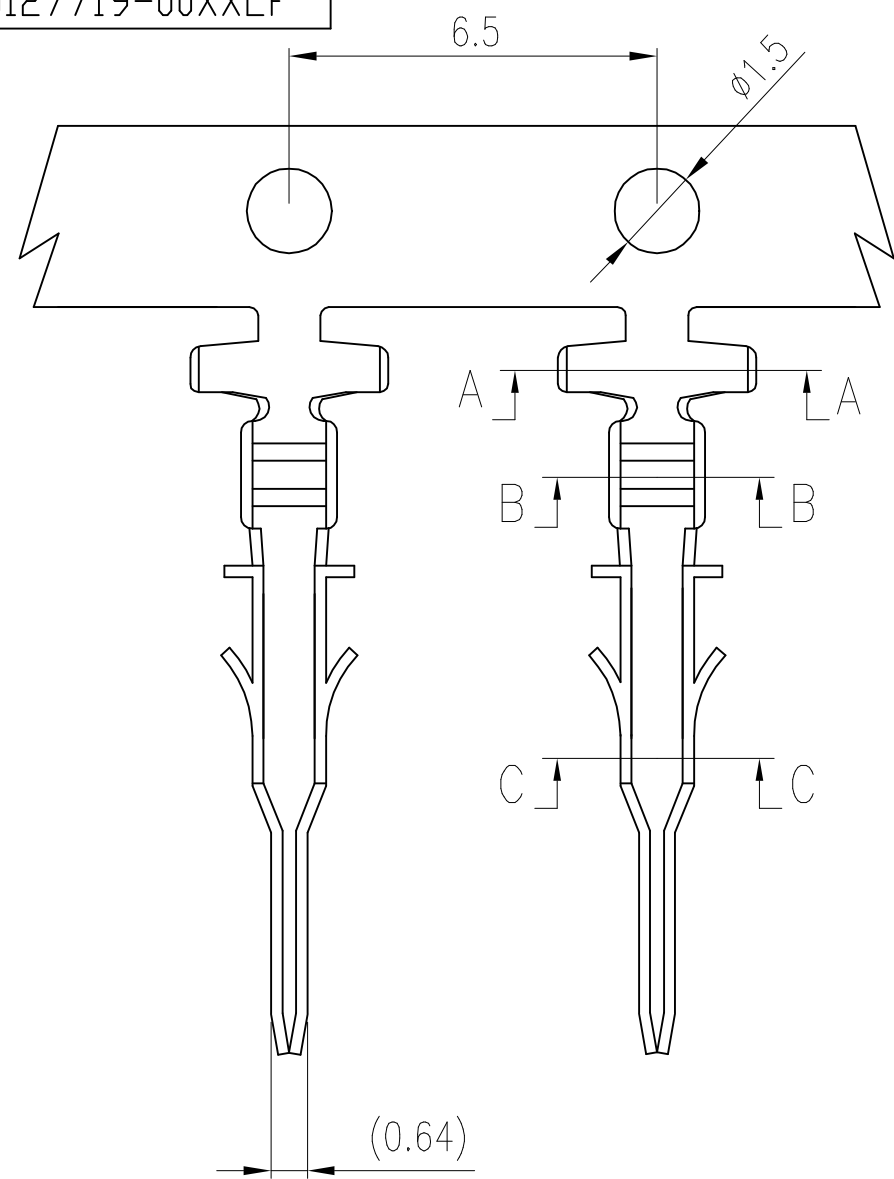

NOTES:

- MATERIAL:
TERMINAL: PHOSPHORUS BRONZE
- PLATING:
CONTACT AREA : OPTIONAL
CRIMP AREA : 80 μ " MIN. BRIGHT TIN
UNDER PLATING : MIN. 30 μ " NICKEL OVERALL
- REFER GS-20-0399 APPLICATION SPECIFICATION FOR MATING CONNECTOR
- PRODUCT SPECIFICATION: GS-12-1177.
- REEL PACKING SPECIFICATION: GS-14-2359.
- APPLICATION SPECIFICATION : GS-20-0399
- MAXIMUM INSULATION DIAMETER : 1.85mm
- LEAD FREE PRODUCTS MEET EUROPEAN UNION DIRECTIVES AND OTHER COUNTRY REGULATIONS AS DESCRIBED IN GS-47-0004
- PRODUCT NUMBER SCHEME:

10127719-X 0 X X LF

APPLICABLE WIRE
0: 20-24 AWG

PLATING TYPE
P: PRE-PLATED
BLANK: POST-PLATED

PLATING CODE
1: 80 μ " BRIGHT TIN OVERALL
2: GOLD FLASH (POST-PLATED).
3: 15 μ " Au (POST-PLATED)
4: 30 μ " Au (POST-PLATED)

| | | | | | | | | | |
|-------------|--|----------------|--|------------------|--|---------------------------------------|--|-------------------------------|--|
| mat'l. code | | surface | | tolerance | | projection | | product family | |
| | | ISO 1302 | | ISO 406 ISO 1101 | | mm | | MINITEK PWR 3.0 | |
| ltr | | ecn no | | date | | tolerances unless otherwise specified | | title | |
| A | | TAI | | 2013-10-21 | | angles linear | | PLUG CRIMP TERMINAL FOR | |
| B | | ELX-T-17032 | | TAI | | .0 \pm .30 | | MINITEK PWR3.0 WIRE CONNECTOR | |
| C | | ELX-T-18006 | | TAI | | .00 \pm .20 | | sheet 1 of 1 size | |
| D | | ELX-T-24280 | | TAI | | 0 \pm 3' | | 10127719 A3 | |
| E | | ELX-I-43461 | | AKHIL | | 2022-01-21 | | type Product Customer Drawing | |
| sheet index | | revision sheet | | E 1 | | KENNY TAI 2013-10-21 | | Amphenol FCI | |
| | | | | | | AKHIL RAJAN 2022-01-21 | | | |
| | | | | | | MITHUN PAUL 2022-01-21 | | | |
| | | | | | | SPK 2022-01-21 | | | |