

DATE	REV	ECN	APP'D. BY
04/08/21	A0	-	JME

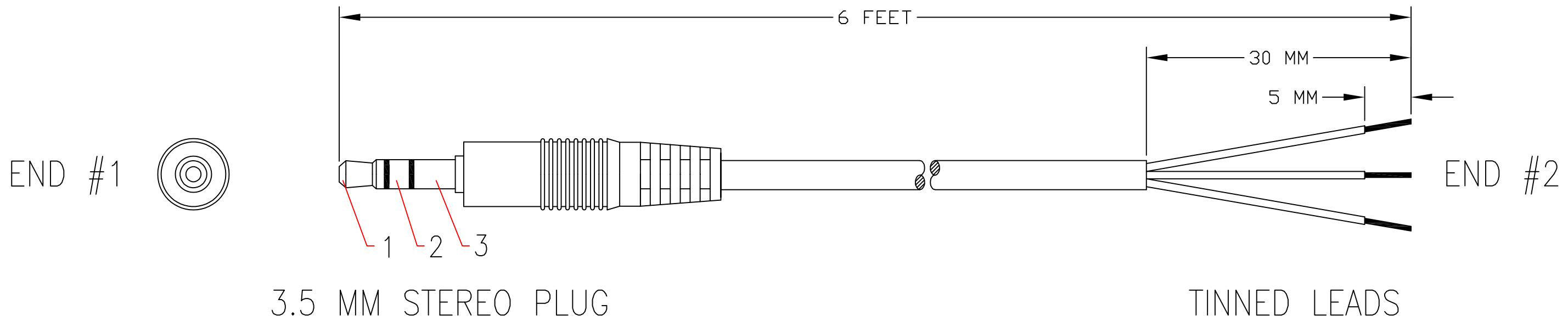

3.5 MM STEREO PLUG

TINNED LEADS

**P/N STRUCTURE**  
 BC-A3ML006F

- UNITS  
F = FEET
- LENGTH  
006 = 6.0
- END #2  
L = LEADS
- END #1  
M = MALE
- CONNECTOR TYPE  
3 = 3 PIN STEREO
- CODE  
A = AUDIO
- FAMILY

- NOTES:**
1. CABLE: 26 AWG + TALC, 3.5MM OD, BLACK JACKET
  2. CONNECTORS:  $\phi$  3.5mm 3 PIN STEREO PLUG, MALE, MOLDED BLACK PVC
  2. LEADS: 30 MM STRIPPED JACKET, 5 MM TINNED

WIRING DIAGRAM

3.5 MM SP	LEADS
1	————— TINNED 5mm BROWN
2	————— TINNED 5mm RED
3	————— TINNED 5mm BLACK



THIRD ANGLE PROJECTION 		206 Van Vorst Street Jersey City, NJ 07302 +1 201 432 0463 <a href="http://www.belfuse.com">http://www.belfuse.com</a>
DO NOT SCALE DRAWING DRAWING IS SUBJECT TO CHANGE WITHOUT NOTICE	TITLE: 3.5 MM STEREO PLUG, MALE, TO STRIPPED LEADS CABLE ASSEMBLY	
DIMENSIONS: INCHES [METRIC] UNLESS OTHERWISE SPECIFIED TOLERANCES ARE $\pm$ .005 [0.13] ANGLES ARE $\pm$ 1°	DRN BY: BTS DATE: 04/07/21	APPD BY: JME DATE: 04/08/21
SHEET NO. 1 OF 1	DWG NO. CT999253	REV. A0