

PRODUCT NUMBER

5 2 6 0 1 - X X X - X X X X X LF

PLATING

S=15μm[0.38μm]GOLD ON CONTACT AREA (NOTE 13)  
100μm[2.54μm]TIN ON TAIL

G=30μm[0.76μm]GOLD ON CONTACT AREA (NOTE 13)  
100μm[2.54μm]TIN ON TAIL

1=30μm[0.76μm] Au PLATING

LEAD FREE OPTION  
NOTE 10,11,12

PACKAGE NOTE 5

RETENTION  
R= RETENTIVE LEG (NOTE 6)

POLARIZATION  
NOTE 9

TAIL		
1	.090/2.29	OBS.
2	.112/2.84	OBS.
4	.120/3.05	
6	.150/3.81	
7	.675/17.15	OBS.
8	SMT	

	TOTAL POSITIONS	HDR. STYLE
10	2 x 5	B
14	2 x 7	C
16	2 x 8	D
20	2 x 10	D
26	2 x 13	D
30	2 x 15	D
34	2 x 17	D
40	2 x 20	D
44	2 x 22	D
50	2 x 25	D
60	2 x 30	D

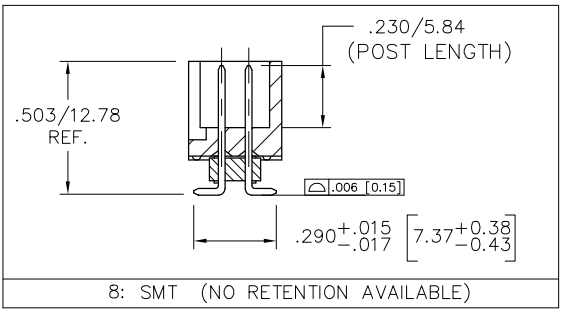

NOTES:

- HOUSING MAT'L: HIGH TEMPERATURE THERMOPLASTIC. UL94V-0  
COLOR: BLACK  
OR  
MINERAL FILLED LCP FLAME RETARDENT  
PER UL-94V-0. COLOR: BLACK.
- PIN MATERIAL: PHOSPHOR-BRONZE
- TO DETERMINE DIMENSIONS:  
N = NUMBER OF POSITIONS PER ROW  
EXAMPLE: 10 POS.,(N-1) x .100[2.54]=.900[22.86]
- 3 LBS./1.36 KG MIN. RETENTION
- PACKAGED IN TRAYS,  
PART NUMBER FOLLOWS BY "T" SUFFIX ARE PACKAGED  
TAPE ON REEL WITH PACK-UP INSTALLED. VACUUM CAP TO BE  
CENTRALLY LOCATED REGARDLESS OF NUMBER OF POSITIONS (SHEET 3)
- RETENTIVE LEG APPLICABLE TO TAIL LENGTHS .125/3.18 MAX.  
5LB/2.3KG MAX INSERTION FORCE AND .25LB./1KG MIN RETENTION FORCE  
PER RETENTIVE PIN USING .062/1.57 THICK CIRCUIT BOARD AND RECOMMENDED  
HOLE PATTERN. RETENTIVE LOCATION AT THE DISCRETION OF THE MANUFACTURER.  
RETENTION PIN MAY BE SHIFTED TO NEXT POSITION.
- OMIT FROM PRODUCT NUMBER IF THIS FEATURE IS NOT APPLICABLE.
- UNDERPLATING: 50μm/1.27μm Ni.
- FOR POLARIZATION SPECIFY POSITION NUMBER (i.e. 03 = PIN 3) TO OMIT PIN.  
OMIT FROM PRODUCT NUMBER IF THIS FEATURE IS NOT APPLICABLE.
- ADD "LF" SUFFIX AT THE END OF PART NUMBER FOR LEAD FREE OPTION.
- THE HOUSING WILL WITHSTAND EXPOSURE TO 260°C PEAK TEMPERATURE  
FOR 15 SECONDS IN A WAVE SOLDER APPLICATION WITH A 1.5mm  
MINIMUM THICK CIRCUIT BOARD. SEE APPLICATION NOTES/PROCEDURES  
IF THEY ARE AVAILABLE.  
  
THE HOUSING WILL WITHSTAND EXPOSURE TO 260°C PEAK TEMPERATURE  
FOR 20 SECONDS IN A CONVECTION, INFRA-RED OR VAPOR PHASE  
REFLOW OVEN. SEE APPLICATION NOTES/PROCEDURES IF THEY ARE AVAILABLE.
- THIS PRODUCT MEETS EUROPEAN UNION DIRECTIVES AND OTHER  
COUNTRY REGULATION AS DESCRIBED IN GS-22-008.
- PLATING OPTIONS:  
MAY BE EITHER GOLD OR GXT PLATED AT MANUFACTURER'S OPTION.

mat'l. code NOTES 1		surface ISD 1302 ✓		tolerance ISD 405 ISD 1101		projection INCH/MM		product family QUICKIE	
ltr	ecn no	dr	date	tolerances unless otherwise specified		title		sheet 1 of 3	
V	M08-0261	MHT	09/30/08	angles	linear	0.100/2.54MM LOW PROFILE SHROUDED VERTICAL HEADER		size	
W	N08-0279	MHT	09/30/08			scale 1:1		A3	
X	N10-0327	A.ZH	11/04/10	0°±2°		Amphenol FCI		52601	
Y	ELX-N-38872	MKX	2020-11-04	dr	D.INGRAM	07/07/99		type Product Customer Drawing	
				enr	L.GREEN	07/12/99			
				chr	L.GREEN	07/12/99			
				appd	L.GREEN	07/21/99			
sheet index	revision sheet	Y	Y	Y					
		1	2	3					

Amphenol  
FCI

© 2016 AFCI

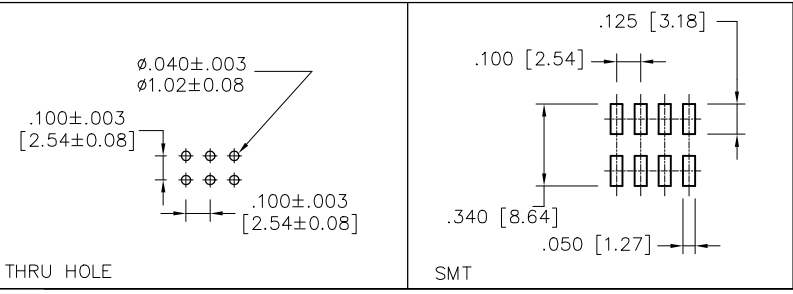
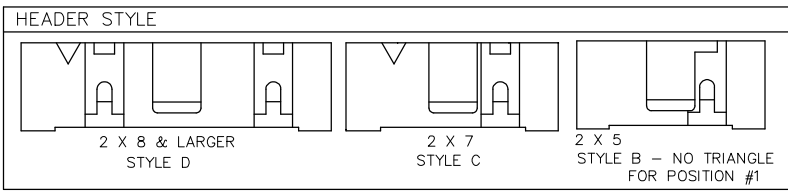
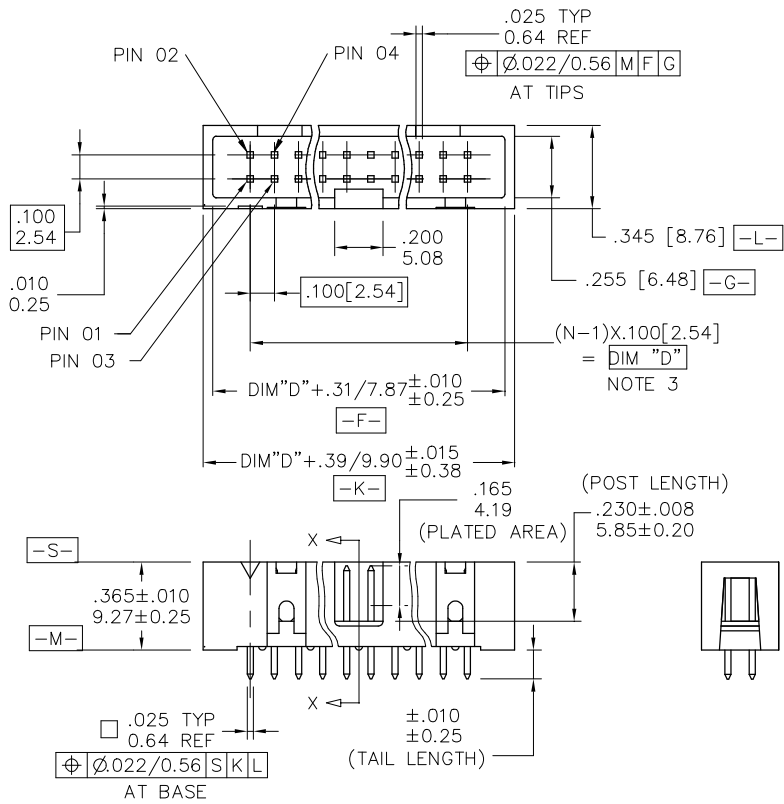

RECOMMENDED BOARD LAYOUT

mat'l. code NOTES 1		surface ISD 1302 ✓	tolerance ISD 405 ISD 1101	projection INCH/MM	product family QUICKIE
ltr	ecn no	dr	date	tolerances unless otherwise specified	
V	M08-0261	MHT	09/30/08	angles	.xx±01/.xx±3
W	N08-0279	MHT	09/30/08	linear	.xxxx±0.005/.xxx±.13
X	N10-0327	A.ZH	11/04/10	0°±2°	.xxxx±0.002/.xxx±.050
Y	ELX-N-38872	MKX	2020-11-04	dr	D.INGRAM 07/07/99
				enr	L.GREEN 07/12/99
				chr	L.GREEN 07/12/99
				appd	L.GREEN 07/21/99
sheet index	revision sheet	See Sheet 1		Amphenol FCI	
		1	2	3	
		title 0.100/2.54MM LOW PROFILE SHROUDED VERTICAL HEADER		dwg no 52601	
		type Product Customer Drawing		sheet 2 of 3 size A3	

PRODUCT No. NOTE 10	NO. OF POSITIONS	HSG. STYLE	POLARIZED POSITION	PACKAGING	POCKET PITCH	DIM M	DIM N
52601-S10-801T	2 X 5	B	01	TAPE-ON-REEL	0.787/20.00	1.260/32.00	0.790/20.07
52601-S10-805T	2 X 5	B	05	TAPE-ON-REEL	0.787/20.00	1.260/32.00	0.790/20.07
52601-S10-807T	2 X 5	B	07	TAPE-ON-REEL	0.787/20.00	1.260/32.00	0.790/20.07
52601-S14-807T	2 X 7	C	07	TAPE-ON-REEL	0.787/20.00	1.732/44.00	1.090/27.69
52601-S14-80714T	2 X 7	C	07,14	TAPE-ON-REEL	0.787/20.00	1.732/44.00	1.090/27.69
52601-X16-8T	2 X 8	D	-	TAPE-ON-REEL	0.787/20.00	1.732/44.00	1.090/27.69
52601-X20-8T	2 X 10	D	-	TAPE-ON-REEL	0.787/20.00	2.204/56.00	1.290/32.77
52601-X30-8T	2 X 15	D	-	TAPE-ON-REEL	0.787/20.00	2.834/72.00	1.786/45.37
52601-X40-8T	2 X 20	D	-	TAPE-ON-REEL	0.787/20.00	3.465/88.00	2.293/58.25

\* SPECIAL CUSTOMER

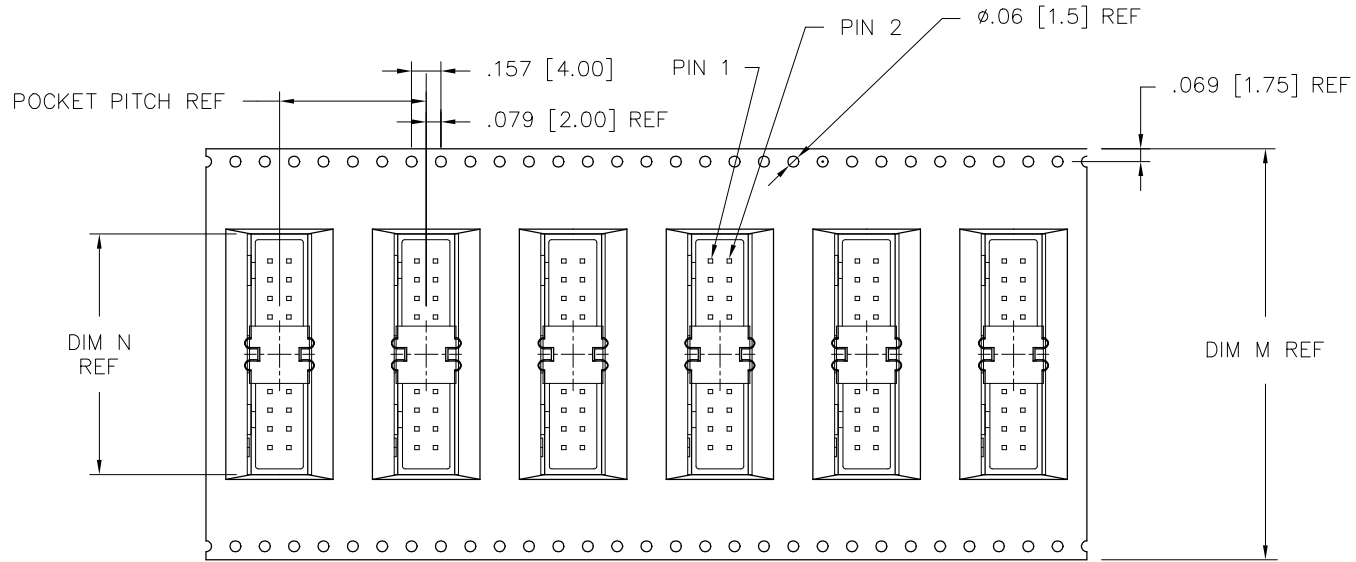

UN-REELING DIRECTION OF FEED →

mat'l. code		surface		tolerance		projection		product family	
NOTES 1		ISD 1302 ✓		ISD 405 ISD 1101				QUICKIE	
ltr	ecn no	dr	date	tolerances unless otherwise specified				title	
V	M08-0261	MHT	09/30/08	angles	linear	.XX±01/.X±3		0.100/2.54MM LOW PROFILE	
W	N08-0279	MHT	09/30/08			.XXX±0.005/.XXX±.13		SHOROUDED VERTICAL HEADER	
X	N10-0327	A.ZH	11/04/10	0°±2°		.XXX±0.002/.XXX±.050		scale 1:1	
Y	ELX-N-38872	MXX	2020-11-04	dr	D.INGRAM	07/07/99		dwg no	
				enr	L.GREEN	07/12/99		sheet 3 of 3	
				chr	L.GREEN	07/12/99		size	
				appd	L.GREEN	07/21/99		52601	
sheet index		revision		See Sheet 1		Amphenol FCI		type Product Customer Drawing	
		sheet	1	2	3				