

- △1 HOUSING: NYLON OR POLYESTER, FLAME RETARDANT, UL 94V-0 RATED, GLASS FILLED, COLOR BLACK.
CONTACTS: BRASS.
SHELL: CARBON STEEL.
EYELETS: BRASS.
BOARDLOCKS: COPPER ALLOY.
INSERTS: ZINC ALLOY.
SCREWLOCKS: ZINC ALLOY.
- △2 CONTACTS: SEE TABLE.
SHELL: 2.54µm [.000100] MIN TIN OVER 1.27µm [.000050] MIN COPPER.
EYELETS: 5.08µm [.000200] MIN TIN OVER COPPER FLASH.
BOARDLOCKS: 5.08µm [.000200] MIN TIN OVER 1.27µm [.000050] MIN NICKEL.
INSERTS: CLEAR CHROMATE.
SCREWLOCKS: CLEAR CHROMATE.
- △3 GOLD FLASH ON THE MATING SURFACES, 2.54µm [.000100] MIN TIN PLATE ON THE SOLDER END, 1.27µm [.000050] MIN NICKEL UNDERPLATE ON THE ENTIRE CONTACT.
- △4 0.76µm [.000030] MIN GOLD PLATE ON THE MATING SURFACES, 2.54µm [.000100] MIN TIN PLATE ON THE SOLDER END, 1.27µm [.000050] MIN NICKEL UNDERPLATE ON THE ENTIRE CONTACT -OR- GOLD FLASH OVER PALLADIUM-NICKEL PLATE, 0.76µm [.000030] MIN TOTAL ON THE MATING SURFACES, 2.54µm [.000100] MIN TIN PLATE ON THE SOLDER END, 1.27µm [.000050] MIN NICKEL UNDERPLATE ON THE ENTIRE CONTACT.
- △5 DIMENSION APPLIES FROM CENTER OF CONTACTS.

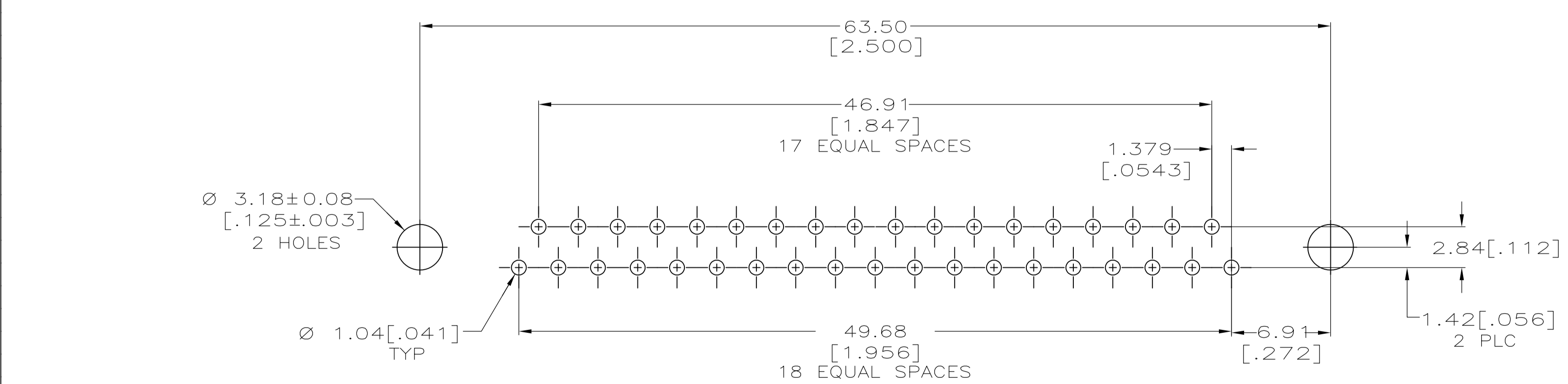
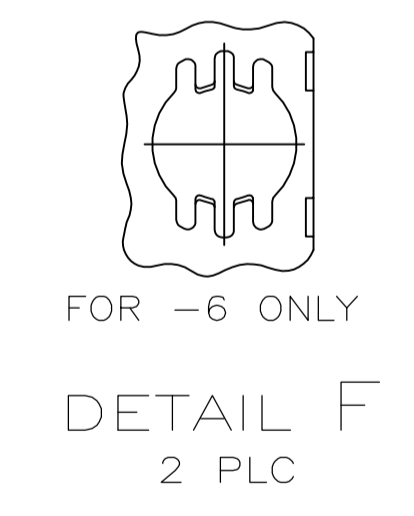
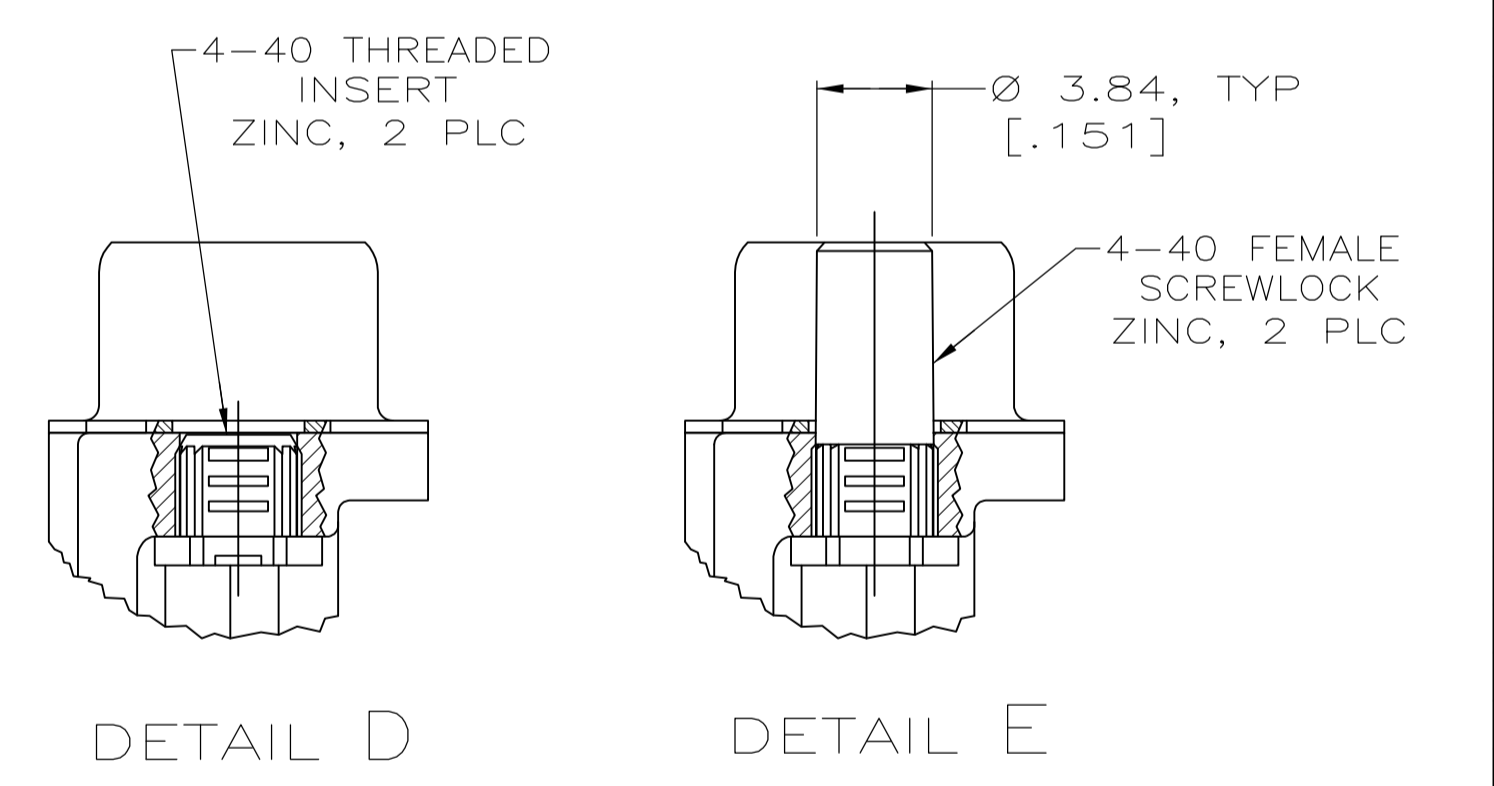
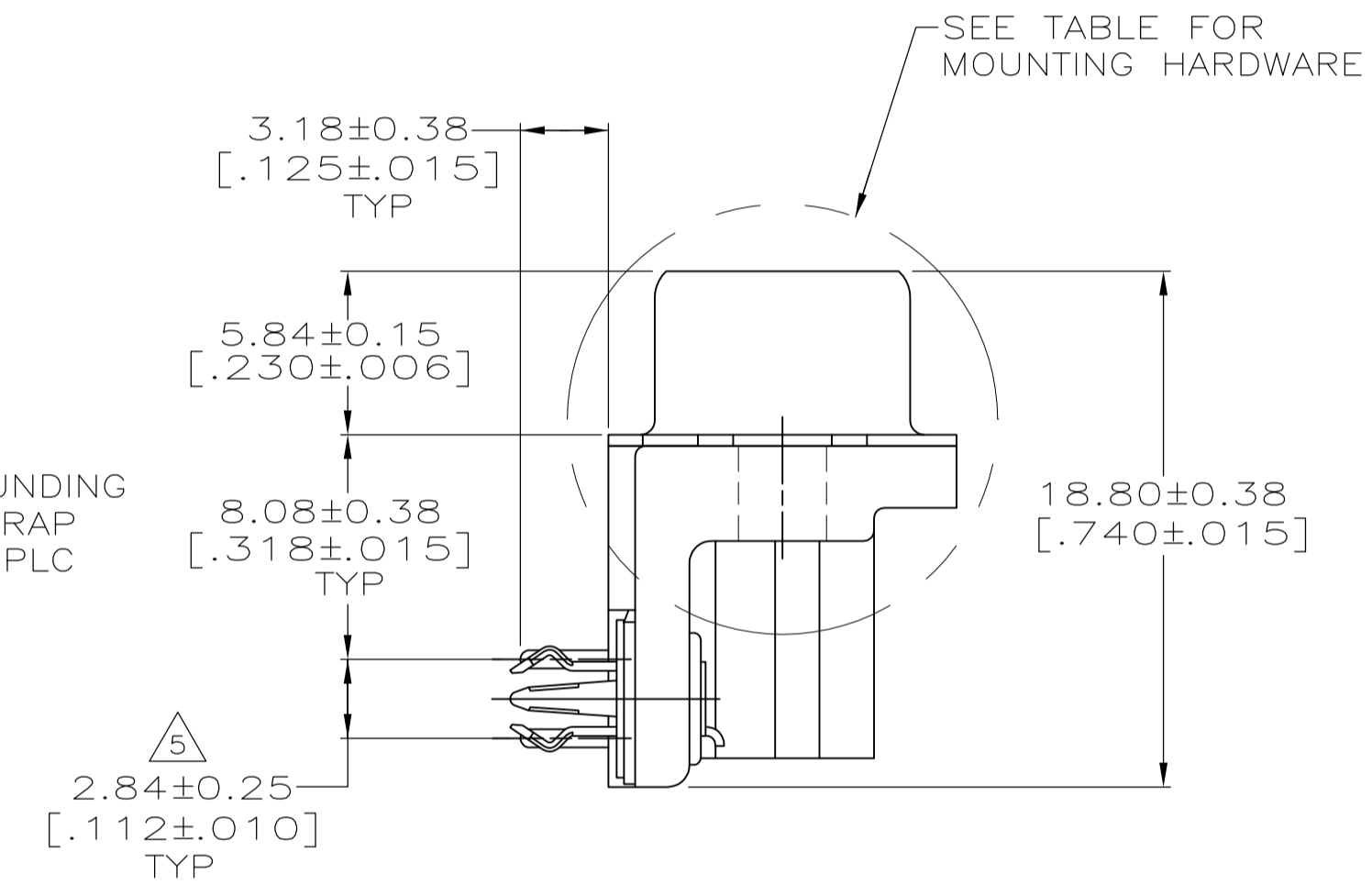
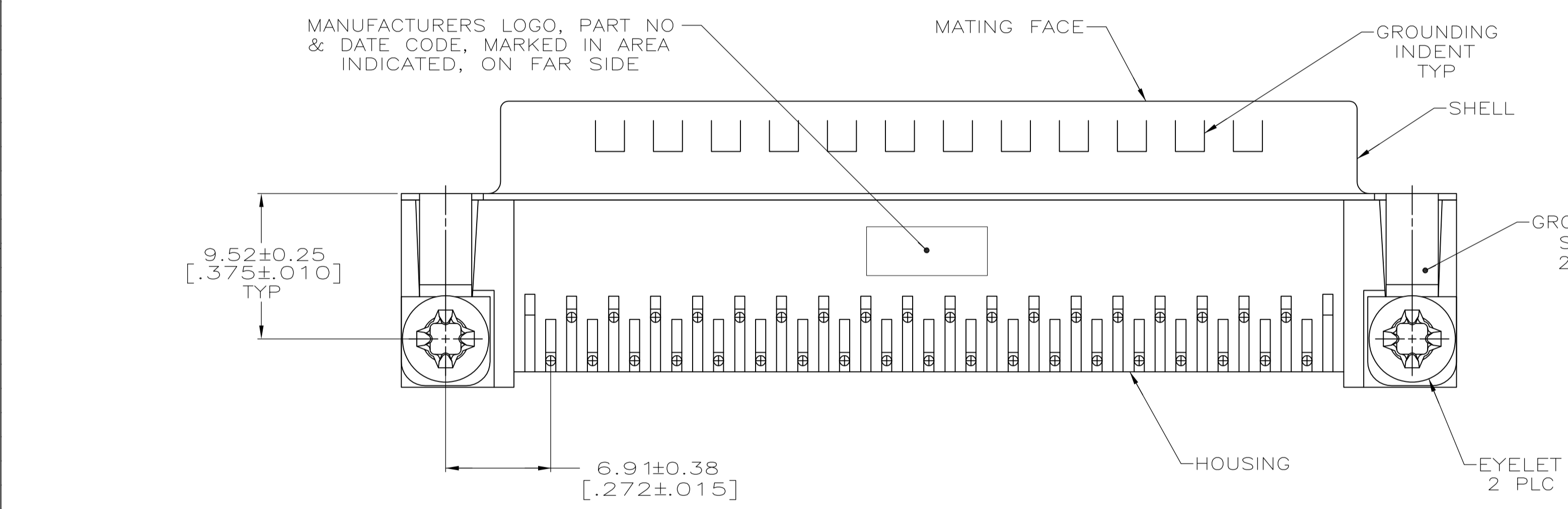

RECOMMENDED P.C. BOARD MOUNTING DIMENSIONS
P.C. BOARD THICKNESS: 1.57 [.062]

SEE DETAIL E	△4	5747843-6
SEE DETAIL D	△4	5747843-4
SEE DETAIL D	△3	5747843-3
NONE	△4	5747843-2
MOUNTING HARDWARE	CONTACT FINISH	PART NUMBER

THIS DRAWING IS A CONTROLLED DOCUMENT. DIMENSIONING AND TOLERANCING PER ASME Y14.5M-2009		DIN G. ATTADIA - 04-13-05		DOCKS - 04-13-05	
DIMENSIONS: mm [INCHES]		TOLERANCES UNLESS OTHERWISE SPECIFIED:		APVD M. WALMSLEY 04-13-05	
0 PLC	± -	NAME		PLUG ASSEMBLY, SIZE 4, 37 POSITION, RIGHT ANGLE, FRONT METAL SHELL, .318 SERIES, BOARDLOCKS, AMPLIMITE HD-20	
1 PLC	± -	PRODUCT SPEC		108-40025	
2 PLC	± -	APPLICATION SPEC		114-40010	
3 PLC	± 0.13 [.005]	SIZE		A1	
4 PLC	± -	CAGE CODE		DRAWING NO	
ANGLES	± -	WEIGHT		00779	
MATERIAL	△1	SCALE		4:1	
FINISH	△2	SHEET		1 OF 1	
CUSTOMER DRAWING		REV		E	