



This document is the property of Amphenol Corporation and is delivered on the express condition that it is not to be disclosed, reproduced or used, in whole or in part, for manufacture or sale by anyone other than Amphenol Corporation without its prior consent, and that no right is granted to disclose or to use any information in this document.

The marking on this product doesn't contain environmental hazardous materials per directive 2011/65/EU & 2015/863/EU for RoHS compliant and per IEC 61249-2-21 for Halogen-Free compliant.



ORIGINAL



REVISIONS				
SYM	ECN No.	DESCRIPTION	DATE	BY
A	NE-12149	RELEASE FOR RoHS	2012-08-16	Debby Hung
B	NE-13034	MODIFY PLATING TO OVERALL	2013-03-13	Debby Hung
C	NE-14168	UPDATE TRAY PACKING QUANTITY ADD T&R AND 2 POS.	2014-09-05	Debby Hung
D	NE-15114	CHG T&R PKG CARRIER WIDTH FROM 24 TO 32	2015-09-15	Aqua Chou
E	NE-19064	CAP'S FOOL-PROOF ,ADD T&R W 44, DATE CODE, PTH NOTE	2020-02-07	Sandy Wu
F	NE-22272	ADD INSULATOR COLOR OPTION: NATURAL	2023-01-12	Karen Su
		ADD 2.60 TAIL LENGTH OPTION/UPDATE PACKAGE		
		CHANGE DIM.0.8 TO 0.7(B3)/ 0.95 TO 0.96(D5)		

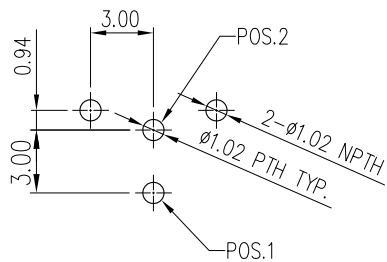
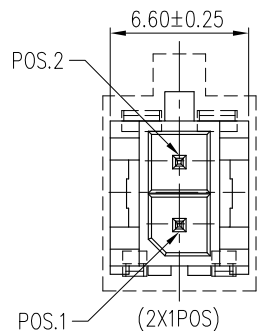

RECOMMENDED PCB LAYOUT (TOP VIEW)  
(ALL TOLERANCES ARE ±0.05)

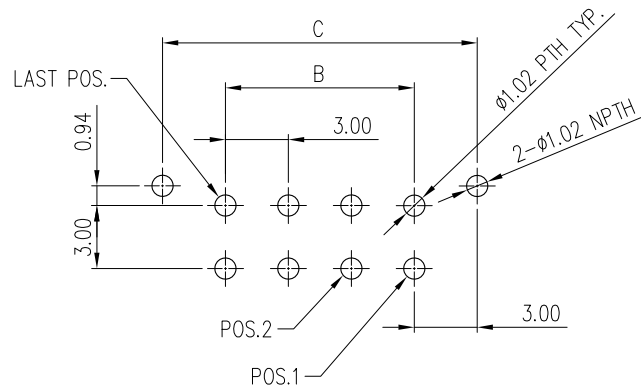
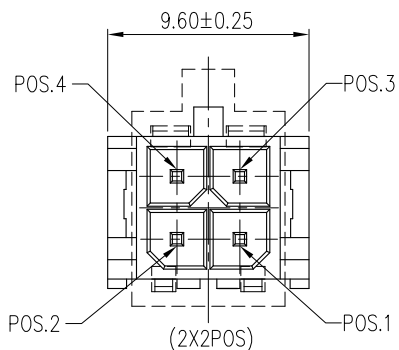

RECOMMENDED PCB LAYOUT (TOP VIEW)  
(ALL TOLERANCES ARE ±0.05)

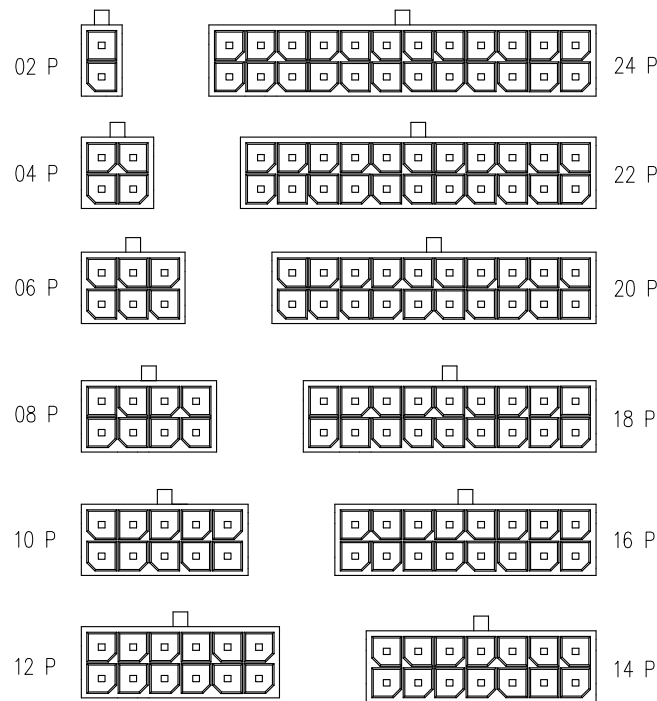
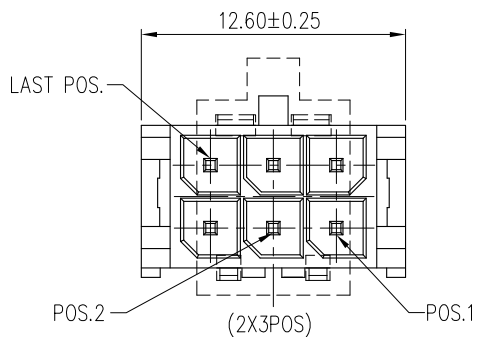

KEY'S DISPLAY DESCRIPTION

TOLERANCE	APPROVALS	DATE	TITLE		Amphenol <sup>®</sup> Amphenol Corporation Amphenol Taiwan Corporation				
X. ±0.30	DRAWN Karen Su	2023-01-12	G881A SERIES MICRO POWER, WAFER 3.00 MM PITCH STRAIGHT DIP, W/O KINK		UNIT mm	SIZE A3	PART No. G881AXX1X2XT3EU	DWG No. G881AXX1X2XT3EU	REV. F
X.X ±0.20	CHECKED Joseph Jiang	2023-01-12							
X.XX ±0.10	APPROVED Roger Tsai	2023-01-12			UNIT mm	SIZE A3	PART No. G881AXX1X2XT3EU		
ANGULAR ±1°	DWG TYPE CUST DWG	PROJECT CODE PHD	SCALE NA	SHEET 2 OF 5					
UNLESS OTHERWISE SPECIFIED									

This document is the property of Amphenol Corporation and is delivered on the express condition that is not to be disclosed, reproduced or used, in whole or in part, for manufacture or sale by anyone other than Amphenol Corporation without its prior consent, and that no right is granted to disclose or to use any information in this document.

The marking on this product doesn't contain environmental hazardous materials per directive 2011/65/EU & 2015/863/EU for RoHS compliant and per IEC 61249-2-21 for Halogen-Free compliant.



ORIGINAL



REVISIONS				
SYM	ECN No.	DESCRIPTION	DATE	BY
A	NE-12149	RELEASE FOR RoHS	2012-08-16	Debby Hung
B	NE-13034	MODIFY PLATING TO OVERALL	2013-03-13	Debby Hung
C	NE-14168	UPDATE TRAY PACKING QUANTITY ADD T&R AND 2 POS.	2014-09-05	Debby Hung
D	NE-15114	CHG T&R PKG CARRIER WIDTH FROM 24 TO 32	2015-09-15	Aqua Chou
E	NE-19064	CAP'S FOOL-PROOF ,ADD T&R W 44, DATE CODE, PTH NOTE	2020-02-07	Sandy Wu
F	NE-22272	ADD INSULATOR COLOR OPTION: NATURAL	2023-01-12	Karen Su
		ADD 2.60 TAIL LENGTH OPTION/UPDATE PACKAGE		
		CHANGE DIM.0.8 TO 0.7(B3)/ 0.95 TO 0.96(D5)		

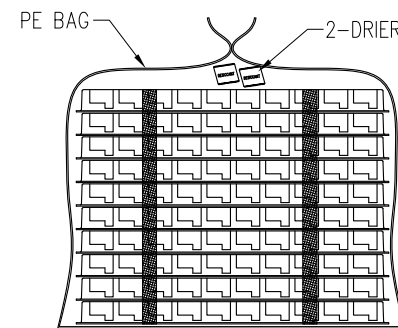
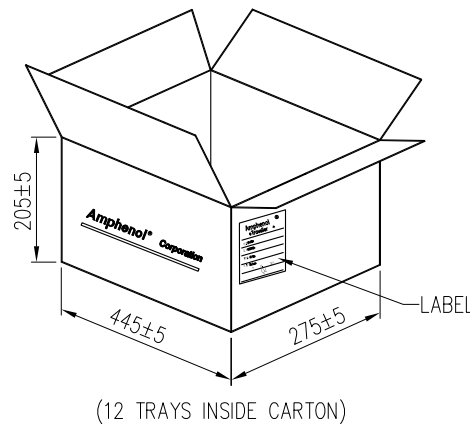
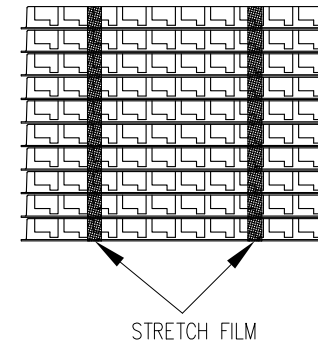
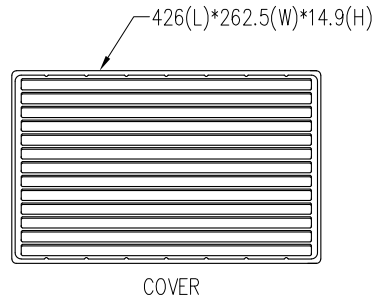
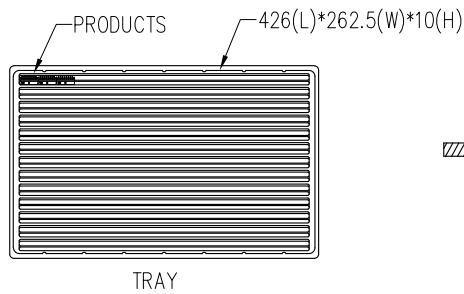

POS	PCS/TRAY	PCS/CARTON
02	900	10800
04	615	7380
06	465	5580
08	375	4500
10	315	3780
12	270	3240
14	240	2880
16	210	2520
18	180	2160
20	165	1980
22	150	1800
24	150	1800

TOLERANCE		APPROVALS		DATE	TITLE		Amphenol <sup>®</sup>						
X.		DRAWN	Karen Su	2023-01-12	G881A SERIES MICRO POWER, WAFER 3.00 MM PITCH STRAIGHT DIP, W/O KINK		Amphenol Corporation Amphenol Taiwan Corporation						
X.X	±0.30	CHECKED	Joseph Jiang	2023-01-12									
X.XX	±0.20	APPROVED	Roger Tsai	2023-01-12									
X.XXX	±0.10						UNIT	mm	SIZE	A3	PART No.	G881AXX1X2XT3EU	
ANGULAR	±1°						SCALE	NA	SHEET	3 OF 5	DWG No.	G881AXX1X2XT3EU	
UNLESS OTHERWISE SPECIFIED		DWG TYPE		CUST DWG	PROJECT CODE		PHD				REV.		F

This document is the property of Amphenol Corporation and is delivered on the express condition that it is not to be disclosed, reproduced or used, in whole or in part, for manufacture or sale by anyone other than Amphenol Corporation without its prior consent, and that no right is granted to disclose or to use any information in this document.

The marking on this product doesn't contain environmental hazardous materials per directive 2011/65/EU & 2015/863/EU for RoHS compliant and per IEC 61249-2-21 for Halogen-Free compliant.



ORIGINAL



REVISIONS				
SYM	ECN No.	DESCRIPTION	DATE	BY
A	NE-12149	RELEASE FOR RoHS	2012-08-16	Debby Hung
B	NE-13034	MODIFY PLATING TO OVERALL	2013-03-13	Debby Hung
C	NE-14168	UPDATE TRAY PACKING QUANTITY ADD T&R AND 2 POS.	2014-09-05	Debby Hung
D	NE-15114	CHG T&R PKG CARRIER WIDTH FROM 24 TO 32	2015-09-15	Aqua Chou
E	NE-19064	CAP'S FOOL-PROOF ,ADD T&R W 44, DATE CODE, PTH NOTE	2020-02-07	Sandy Wu
F	NE-22272	ADD INSULATOR COLOR OPTION: NATURAL	2023-01-12	Karen Su
		ADD 2.60 TAIL LENGTH OPTION/UPDATE PACKAGE		
		CHANGE DIM.0.8 TO 0.7(B.3)/ 0.95 TO 0.96(D5)		

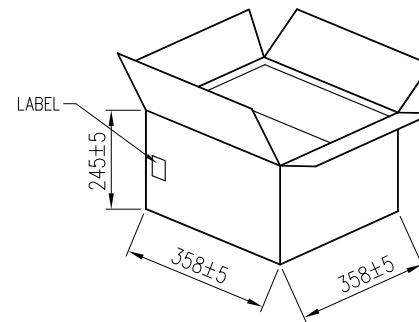
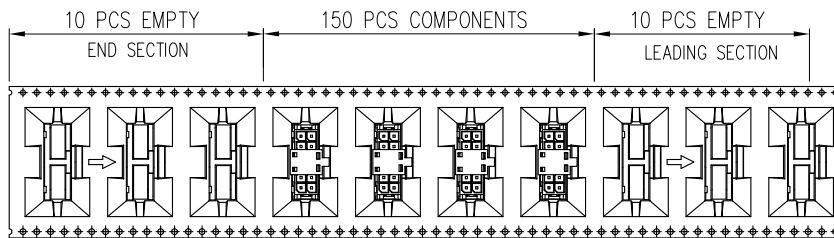
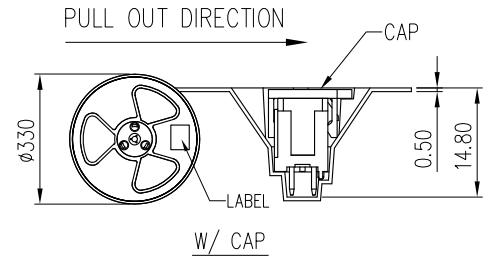
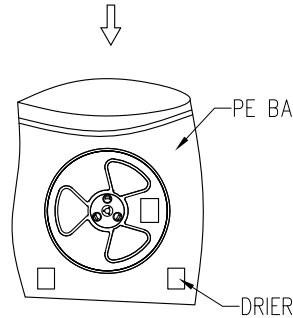
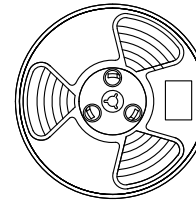
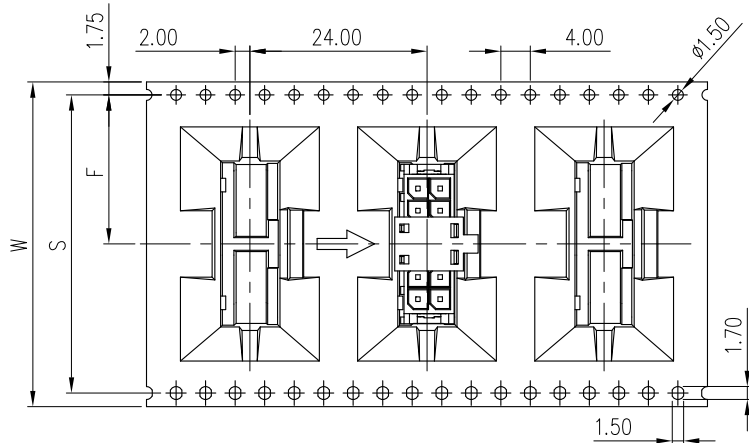

POS.	W	S	F	PCS REEL	REELS CARTON	QUANTITY (PCS)
02	32.0	28.4	14.2	150	6	900
04	44.0	40.4	20.2	150	4	600
06				150	4	600
08				150	4	600
10				150	4	600
12	72.0	68.4	34.2	150	3	450
14				150	3	450
16				150	3	450
18				150	3	450
20				150	3	450
22				150	3	450
24				150	3	450

TOLERANCE		APPROVALS		DATE	TITLE		Amphenol <sup>®</sup>				
X.		DRAWN	Karen Su	2023-01-12	G881A SERIES MICRO POWER, WAFER 3.00 MM PITCH STRAIGHT DIP, W/O KINK		Amphenol Corporation Amphenol Taiwan Corporation				
X.X	±0.30	CHECKED	Joseph Jiang	2023-01-12							
X.XX	±0.20	APPROVED	Roger Tsai	2023-01-12							
X.XXX	±0.10	DWG TYPE	CUST DWG	PROJECT CODE	PHD	UNIT	mm	SIZE	A3	PART No.	G881AXX1X2XT3EU
ANGULAR	±1°					SCALE	NA	SHEET	4 OF 5	DWG No.	G881AXX1X2XT3EU
UNLESS OTHERWISE SPECIFIED										REV.	F

This document is the property of Amphenol Corporation and is delivered on the express condition that is not to be disclosed, reproduced or used, in whole or in part, for manufacture or sale by anyone other than Amphenol Corporation without its prior consent, and that no right is granted to disclose or to use any information in this document.

The marking on this product doesn't contain environmental hazardous materials per directive 2011/65/EU & 2015/863/EU for RoHS compliant and per IEC 61249-2-21 for Halogen-Free compliant.



ORIGINAL



REVISIONS				
SYM	ECN No.	DESCRIPTION	DATE	BY
A	NE-12149	RELEASE FOR RoHS	2012-08-16	Debby Hung
B	NE-13034	MODIFY PLATING TO OVERALL	2013-03-13	Debby Hung
C	NE-14168	UPDATE TRAY PACKING QUANTITY ADD T&R AND 2 POS.	2014-09-05	Debby Hung
D	NE-15114	CHG T&R PKG CARRIER WIDTH FROM 24 TO 32	2015-09-15	Aqua Chou
E	NE-19064	CAP'S FOOL-PROOF ,ADD T&R W 44, DATE CODE, PTH NOTE	2020-02-07	Sandy Wu
F	NE-22272	ADD INSULATOR COLOR OPTION: NATURAL ADD 2.60 TAIL LENGTH OPTION/UPDATE PACKAGE CHANGE DIM.0.8 TO 0.7(B3)/ 0.95 TO 0.96(D5)	2023-01-12	Karen Su

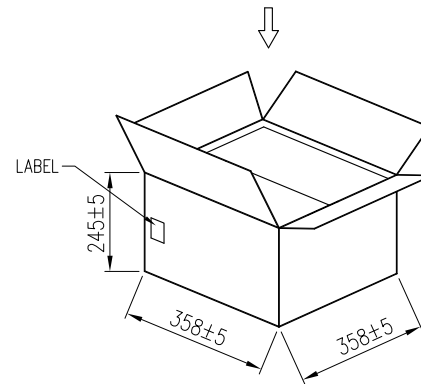
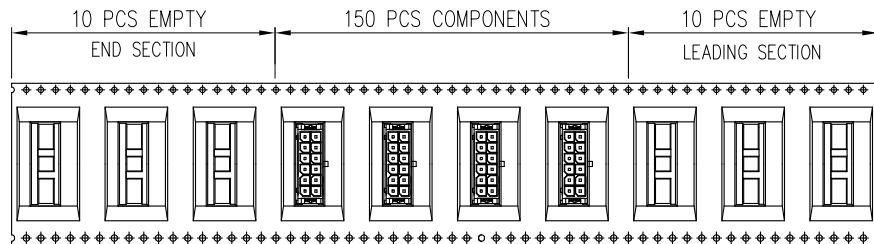
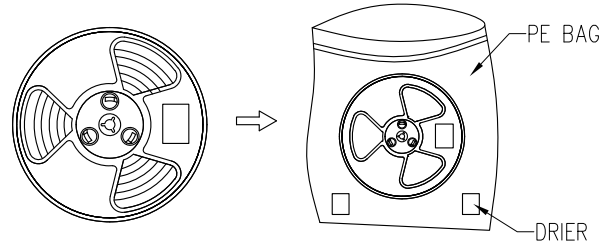
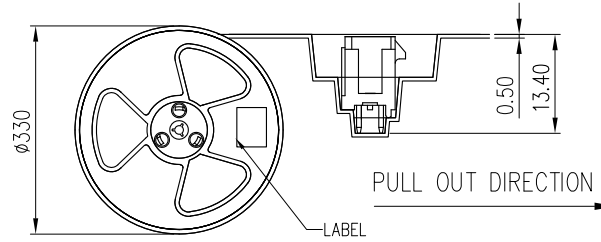
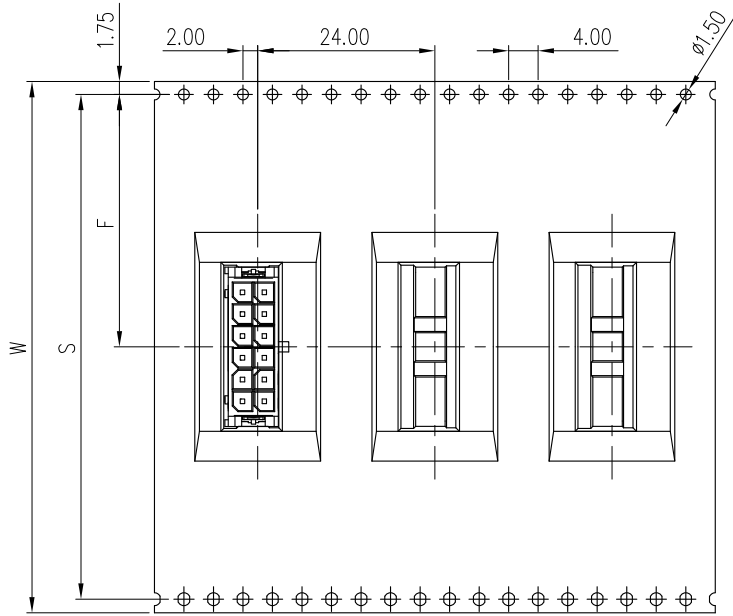

POS.	W	S	F	PCS REEL	REELS CARTON	QUANTITY (PCS)
02	32.0	28.4	14.2	150	6	900
04	72.0	68.4	34.2	150	3	450
06				150	3	450
08				150	3	450
10				150	3	450
12				150	3	450
14				150	3	450
16				150	3	450
18				150	3	450
20				150	3	450
22				150	3	450
24	150	3	450			

TOLERANCE	APPROVALS	DATE	TITLE	Amphenol <sup>®</sup> Amphenol Corporation Amphenol Taiwan Corporation		
X. ±0.30 X.X ±0.20 X.XX ±0.10 X.XXX ±0.10	DRAWN Karen Su	2023-01-12	G881A SERIES MICRO POWER, WAFER 3.00 MM PITCH STRAIGHT DIP, W/O KINK	UNIT	SIZE	PART No.
ANGULAR ±1°	CHECKED Joseph Jiang	2023-01-12		mm	A3	G881AXX1X2XT3EU
UNLESS OTHERWISE SPECIFIED	APPROVED Roger Tsai	2023-01-12		SCALE	SHEET	DWG No.
	DWG TYPE CUST DWG	PROJECT CODE PHD	NA	5 OF 5	G881AXX1X2XT3EU	REV. F

