

High Power Silicon Controlled Rectifier

1300 VOLTS 110 ARMS

C150,2



The General Electric C150 and C152 Silicon Controlled Rectifiers are designed for phase control applications. These are all-diffused, Pic-Pac devices employing the field-proven amplifying gate.

FEATURES:

- High di/dt Rating
- High dv/dt Capability with Selections Available
- Excellent Surge and I²t Ratings Providing Easy Fusing
- Rugged Hermetic Package with Long Creepage Path

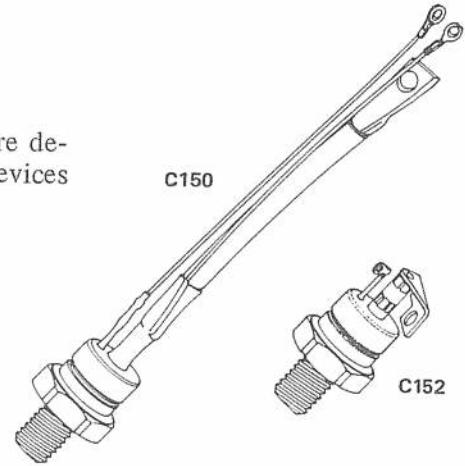

MAXIMUM ALLOWABLE RATINGS

TYPE	REPETITIVE PEAK OFF-STATE VOLTAGE, V_{DRM}^1 $T_J = -40^\circ\text{C to } +125^\circ\text{C}$	REPETITIVE PEAK REVERSE VOLTAGE, V_{RRM}^1 $T_J = -40^\circ\text{C to } +125^\circ\text{C}$	NON-REPETITIVE PEAK REVERSE VOLTAGE, V_{RSM}^1 $T_J = +125^\circ\text{C}$
C150, C152E	500 Volts	500 Volts	600 Volts
C150, C152M	600	600	720
C150, C152S	700	700	850
C150, C152N	800	800	950
C150, C152T	900	900	1075
C150, C152P	1000	1000	1200
C150, C152PA	1100	1100	1325
C150, C152PB	1200	1200	1450
C150, C152PC	1300	1300	1550

¹ Half sinewave waveform, 10 msec. max. pulse width.

RMS On-State Current, $I_{T(RMS)}$	100 Amperes (All Conduction Angles)
Average On-State Current, $I_{T(AV)}$	Depends on Conduction Angle (See Charts 1 and 4)
Peak One-Cycle Surge (Non-Repetitive) On-State Current, I_{TSM} (60 Hz)	1500 Amperes
Peak One-Cycle Surge (Non-Repetitive) On-State Current, I_{TSM} (50 Hz)	1400 Amperes
Critical Rate-of-Rise of On-State Current (Non-Repetitive)*	800 A/ μ s
Critical Rate-of-Rise of On-State Current (Repetitive)*	500 A/ μ s
I ² t (for fusing), for times \geq 1.5 milliseconds	7000 (RMS Ampere) ² Seconds
Peak Gate Power Dissipation, P_{GM}	10 Watts
Average Gate Power Dissipation, $P_{G(AV)}$	2 Watts
Storage Temperature, T_{stg}	-40°C to +150°C
Operating Temperature, T_J	-40°C to +125°C
Stud Torque	125 Lbs.-In. (Min.) – 150 Lbs.-In. (Max.) 14 N-m (Min.) – 17 N-m (Max.)

*di/dt ratings established in accordance with EIA-NEMA Standard RS-397, Section 5.2.2.6 for conditions of V_{DRM} stated above; 20 volts, 20 ohms gate trigger source with 0.5 μ sec short circuit trigger current rise time.

CHARACTERISTICS

TEST	SYMBOL	MIN.	TYP.	MAX.	UNITS	TEST CONDITIONS
Repetitive Peak Reverse and Off-State Current	I_{DRM} and I_{RRM}				mA	$T_J = +25^\circ\text{C}$ $V_{DRM} = V_{RRM} =$
C150, C152E		—	3	10		500 Volts Peak
C150, C152M		—	3	10		600
C150, C152S		—	3	10		700
C150, C152N		—	3	10		800
C150, C152T		—	3	10		900
C150, C152P		—	3	10		1000
C150, C152PA		—	3	10		1100
C150, C152PB		—	3	6		1200
C150, C152PC		—	3	5		1300
Repetitive Peak Reverse and Off-State Current	I_{DRM} and I_{RRM}				mA	$T_J = +125^\circ\text{C}$ $V_{DRM} = V_{RRM}$
C150, C152E		—	15	20		500 Volts Peak
C150, C152M		—	15	20		600
C150, C152S		—	15	20		700
C150, C152N		—	15	20		800
C150, C152T		—	15	20		900
C150, C152P		—	15	20		1000
C150, C152PA		—	15	20		1100
C150, C152PB		—	10	13		1200
C150, C152PC		—	8	11		1300
Thermal Resistance	$R_{\theta JC}$	—	.2	.3	$^\circ\text{C}/\text{Watt}$	Junction-to-Case
Critical Rate-of-Rise of Off-State Voltage (Higher values may cause device switching)	dv/dt	200	500	—	$\text{V}/\mu\text{sec}$	$T_J = +125^\circ\text{C}$, Rated V_{DRM} , Using Linear Exponential Rising Waveform. Gate Open Circuited. Exponential $dv/dt = \frac{V_{DRM}}{\tau}$ (.632)
Higher minimum dv/dt selections available — consult factory.						
Holding Current	I_H	—	20	500	mAdc	$T_C = +25^\circ\text{C}$, Anode Supply = 24 Vdc. Initial Forward Current = 2 Amps.
Turn-On Delay Time	t_d	—	1	—	μsec	$T_C = +25^\circ\text{C}$, $I_T = 50$ Adc, $V_{DRM} = \text{Rated}$. Gate Supply: 10 Volt Open Circuit, 20 Ohm, 0.1 μsec max. rise time
Gate Pulse Width Necessary to Trigger		—	8	10	μsec	$T_C = +25^\circ\text{C}$. Gate Supply: 20 Volt Open Circuit, 40 Ohm, 0.5 μsec rise time. $I_T = 1.0$ Amps. for High di/dt Capability. See Chart 9.
DC Gate Trigger Current	I_{GT}	—	50	150	mAdc	$T_C = +25^\circ\text{C}$, $V_D = 6$ Vdc, $R_L = 3$ Ohms
		—	75	200		$T_C = -40^\circ\text{C}$, $V_D = 6$ Vdc, $R_L = 3$ Ohms
		—	15	125		$T_C = +125^\circ\text{C}$, $V_D = 6$ Vdc, $R_L = 3$ Ohms
DC Gate Trigger Voltage	V_{GT}	—	1.25	3.0	Vdc	$T_C = -40^\circ\text{C}$ to $+120^\circ\text{C}$, $V_D = 6$ Vdc, $R_L = 3$ Ohms
		0.15	—	—		$T_C = +125^\circ\text{C}$, $V_D = \text{Rated}$, $R_L = 1000$ Ohms
Peak On-State Voltage	V_{TM}	—	2.0	2.6	Volts	$T_C = +25^\circ\text{C}$, $I_{TM} = 500$ Amps. Peak. Duty Cycle $\leq 0.01\%$
Circuit Commutated Turn-Off Time**	t_q	—	100	†	μsec	(1) $T_J = +125^\circ\text{C}$ (2) $I_{TM} = 50$ Amps (3) $V_R = 50$ Volts Min. (4) V_{DRM} (Reapplied) = Rated (5) Rate-of-Rise of Reapplied Off-State Voltage = $20\text{V}/\mu\text{sec}$ Linear

† Consult factory if guaranteed turn-off time is required.

** Typical turn-off time increases 30%, if I_{TM} is increased to 500 amps. 819

C150, C152

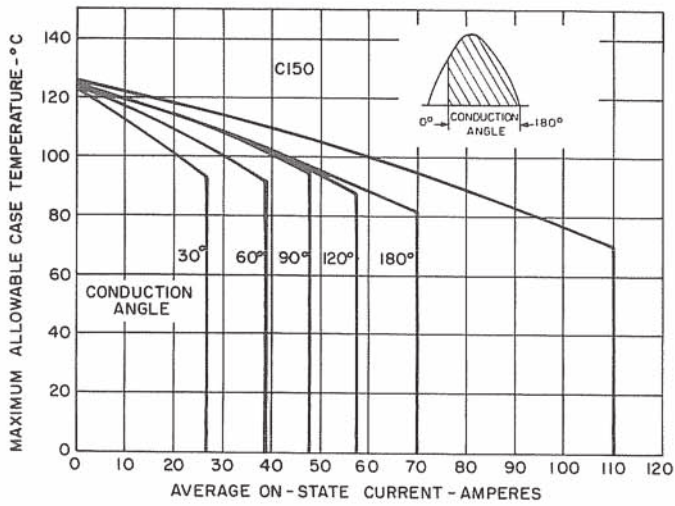

1. MAXIMUM ALLOWABLE CASE TEMPERATURE FOR SINUSOIDAL CURRENT WAVEFORM 50 TO 400 CPS

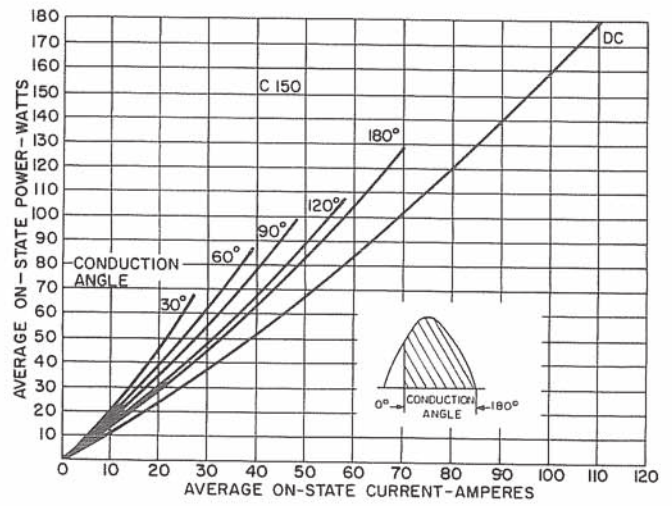

2. MAXIMUM ON-STATE POWER DISSIPATION FOR SINUSOIDAL CURRENT WAVEFORM 50 TO 400 CPS

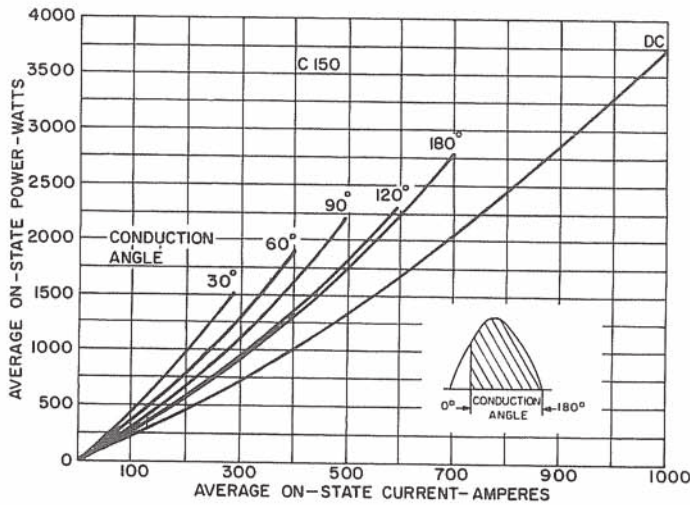

3. MAXIMUM ON-STATE POWER DISSIPATION FOR SINUSOIDAL CURRENT WAVEFORM (EXTENDED RANGE)

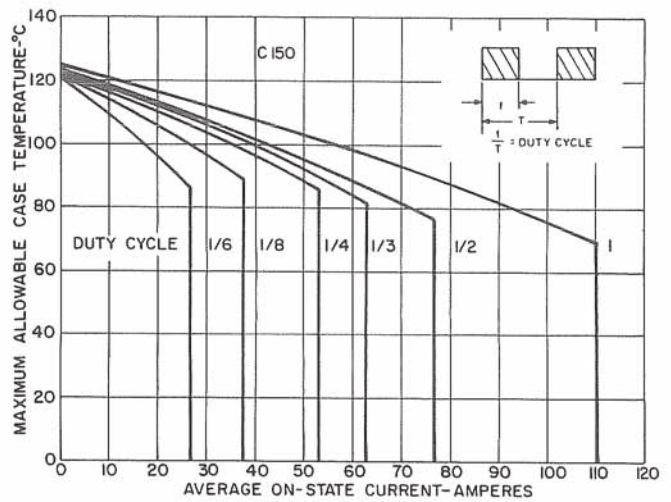

4. MAXIMUM ALLOWABLE CASE TEMPERATURE FOR RECTANGULAR CURRENT WAVEFORM - 50 TO 400 CPS

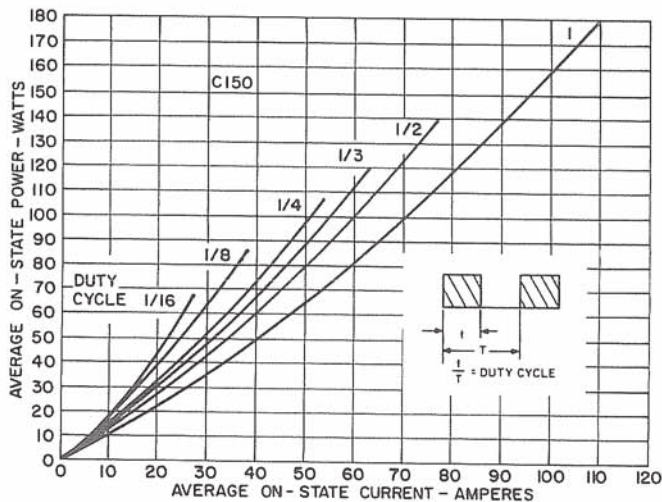

5. MAXIMUM ON-STATE POWER DISSIPATION FOR RECTANGULAR CURRENT WAVEFORM 50 TO 400 CPS

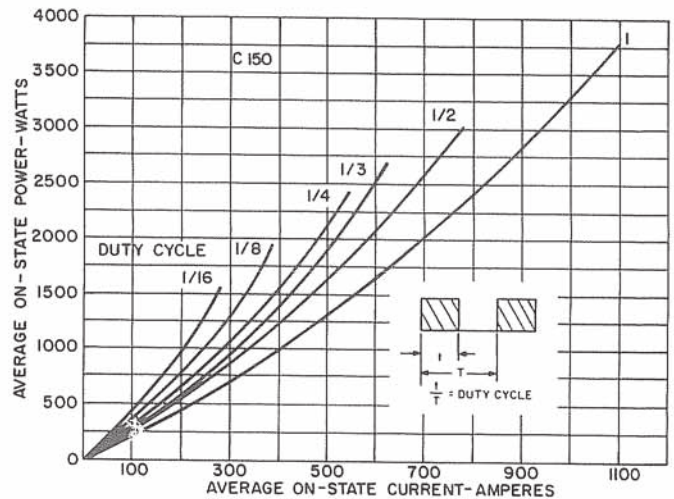

6. ON-STATE POWER DISSIPATION FOR RECTANGULAR CURRENT WAVEFORM 50 TO 400 CPS

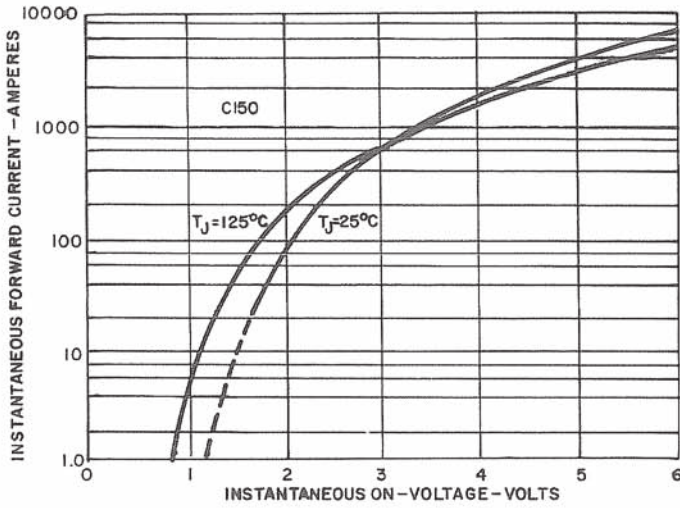

7. C150 FORWARD CONDUCTION CHARACTERISTIC, ON-STATE

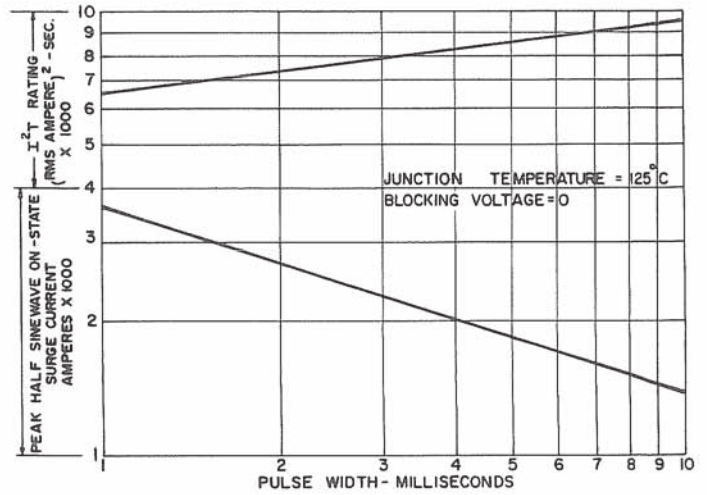

8. SUB-CYCLE SURGE RATING FOLLOWING RATED LOAD CONDITIONS

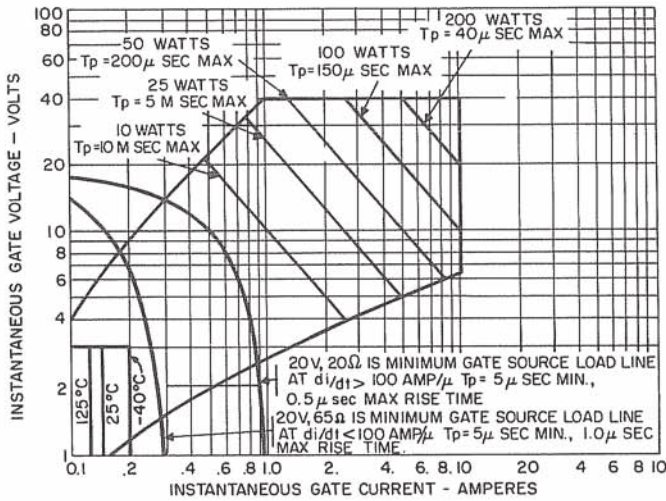

9. GATE TRIGGERING CHARACTERISTICS

NOTES:

1. Maximum allowable gate power dissipation = 2 Watts.
2. The locus of possible DC trigger points lie outside the boundaries shown at various case temperatures.
3. T_p = Rectangular Gate Current Pulse Width.

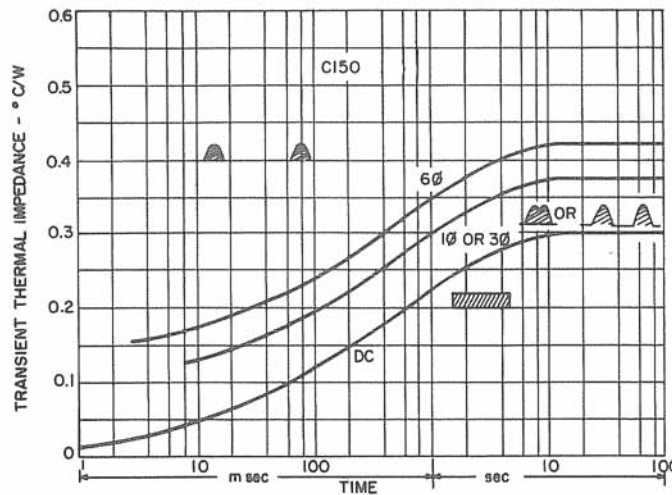

10. TRANSIENT THERMAL IMPEDANCE - JUNCTION-TO-CASE

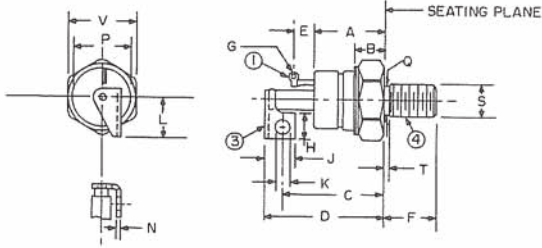

MODEL	TERMINAL ①	TERMINAL ③	TERMINAL ④	S THREAD SIZE
C152	GATE	CATHODE +	ANODE -	1/2-20 UNF-2A

SYM	INCHES		METRIC MM		SYM	INCHES		METRIC MM		NOTES
	MIN.	MAX.	MIN.	MAX.		MIN.	MAX.	MIN.	MAX.	
A	1.020	1.140	25.90	28.96	L	.590	.640	14.98	16.26	
B	.390	.500	9.90	12.70						
C	1.460 REF.		7.92 REF.		N	.058	.070	1.47	1.78	
D	1.660	1.800	42.16	45.72						
E	.312 REF.		7.92 REF.		P	.840	.910	21.33	23.11	
F	.797	.827	20.24	21.01						
G	.060	.075	1.52	1.91	Q	.425	.499	10.79	12.67	
H	.385	.415	9.77	10.54	T	—	.060	—	1.52	2
J	.445	.485	11.30	12.32	V	1.052	1.063	26.72	27.00	
K	.198	.212	5.02	5.38						

NOTES:

1. One nut and one lockwasher supplied with each unit. Material of hardware is steel, cad plated.
2. "T" dimension is area of unthreaded portion. Complete threads are within 2.5 threads of seating plane.
3. Angular orientation of terminals is undefined.

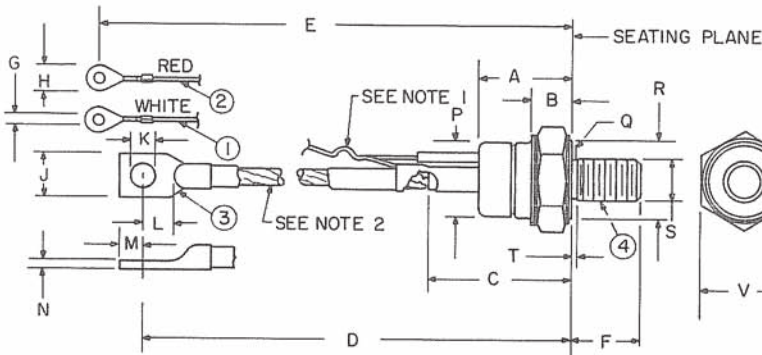

MODEL	TERMINAL ①	TERMINAL ②	TERMINAL ③	TERMINAL ④	S THREAD SIZE
C150	GATE	AUX CATHODE	CATHODE +	ANODE -	1/2 20UNF-2A

SYM	INCHES		METRIC MM		SYM	INCHES		METRIC MM		NOTES
	MIN.	MAX.	MIN.	MAX.		MIN.	MAX.	MIN.	MAX.	
A	1.020	1.140	25.90	28.96	L	.330	—	8.38	—	
B	.390	.500	9.90	12.70	M	.275	.325	6.98	8.26	
C	1.570	1.750	39.87	44.45	N	.065	.095	1.65	2.41	
D	6.000	6.390	152.40	162.31	P	.840	.910	21.33	23.11	
E	6.850	7.500	173.99	190.50	Q	.425	.499	10.79	12.67	
F	.797	.827	20.24	21.01	R	.920	—	23.36	—	4
G	.140	.150	3.55	3.81	T	—	.060	—	1.57	5
H	—	.300	—	7.62						
J	.500	.610	12.70	15.49	V	1.052	1.063	26.72	27.00	
K	.260	.281	6.60	7.14						

NOTES:

1. Gate and auxiliary cathode leads supplied lightly twisted together.
2. Flexible copper lead.
3. One nut and one lockwasher supplied with each unit. Material of hardware is steel, cad plated.
4. "R" dimension is diameter of effective seating area.
5. "T" dimension is area of unthreaded portion. Complete threads are within 2.5 threads of seating plane.
6. Angular orientation of terminals is undefined.

