

IL CAN BK-TC-XC-PAC

Inline CANopen[®] bus coupler Extreme conditions version



Data sheet
106153_en_01

© PHOENIX CONTACT 2014-08-04

1 Description

The Inline CANopen[®] bus coupler allows communication between the I/O modules of the Inline product range and the CANopen[®] network. Diagnostic indicators are provided local Inline I/O communication as well as CANopen[®] communication.

Thanks to special engineering measures and tests, the terminal can be used under extreme ambient conditions.

Inline features

- Connects up to 63 I/O modules
- Programmable fault response modes
- Stored I/O configuration
- Digital inputs with latch function
- Auto configuration
- Up to 510 digital input and output points
- Up to 254 analog input and output points
- Up to 63 intelligent special function modules

CANopen[®] features

- Direct PCP peer-to-peer communication
- Alarm message
- Error states and error values
- Baud rates that can be set: 10 kbaud, 20 kbaud, 50 kbaud, 125 kbaud, 250 kbaud, 500 kbaud, 1 Mbaud
- 32 process data transmit objects and 32 process data receive objects
- Trigger modes: event timer, remote request
- Device guarding and heartbeat
- Analog interrupt triggers:
 - Set upper limit, lower limit
 - Unsigned delta
- Supports two configuration modules simultaneously

Other features

- Can be used under extreme ambient conditions
- Coated PCBs
- Extended temperature range T2 (-40°C ... +55°C)



This data sheet is only valid in association with the IL SYS INST UM E user manual.



Make sure you always use the latest documentation.
It can be downloaded at phoenixcontact.net/products.

2 Table of contents

1	Description.....	1
2	Table of contents	2
3	Ordering data.....	2
4	Technical data	3
6	Design of the bus coupler	6
7	Terminal point assignment.....	6
8	Networking information	8
10	Configuring the bus coupler using the DIP switches.....	10
11	Diagnostics	11
12	Diagnostic and status indicators	12

3 Ordering data

Product

Description	Type	Order No.	Pcs. / Pkt.
CANopen [®] bus coupler, 24 V DC, bus interface 2 x 5-pos. TWIN-COMBICON connector, complete with accessories (connector, labeling field, end brackets)	IL CAN BK-TC-XC-PAC	2702130	1

Accessories

Description	Type	Order No.	Pcs. / Pkt.
End brackets	CLIPFIX 35	3022218	50
Insert strip	ESL 62X10	0809492	1
Labeling field	IB IL FIELD 2	2727501	10
Inline connector (as a replacement item)	IB IL SCN-8-CP	2727608	10

Documentation

Description	Type	Order No.	Pcs. / Pkt.
User manual, English, Automation terminals of the Inline product range	IL SYS INST UM E	-	-
User manual, English, Inline bus coupler for CANopen [®] IL CAN BK-TC-PAC	UM EN IL CAN BK-TC-PAC	-	-
Quick start guide, English, Configuring a CANopen [®] system using SyCon	UM QS EN IL CAN BK-TC-PAC	-	-

4 Technical data

Dimensions (nominal sizes in mm)

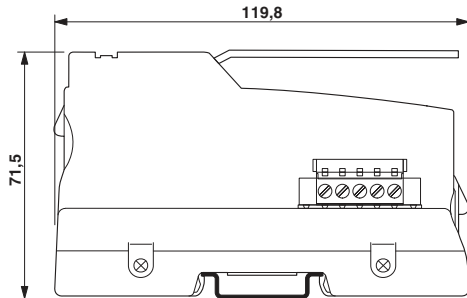

Housing dimensions (width x height x depth)	85 mm x 119.8 mm x 71.5 mm
---	----------------------------

General data

Color	Green
Weight	326 g, approximately (with connectors)
Permissible temperature (operation)	-40°C ... 55°C (see also the "Tested successfully: Use under extreme ambient conditions" section.).
Permissible temperature (storage/transport)	-40°C to +85°C
Permissible humidity (operation/storage/transport)	10% to 95%, according to DIN EN 61131-2
Temperature class	T2 (-40°C ... 55°C, EN 50155)
Permissible air pressure (operation/storage/transport)	70 kPa to 106 kPa (up to 3000 m above sea level)
Degree of protection	IP20
Protection class	III, IEC 61140, EN 61140, VDE 0140-1

Connection data

Designation	Inline connector plug
Connection method	Spring-cage connection
Conductor cross section, solid/stranded	0.08 mm ² ... 1.5 mm ²
Conductor cross section [AWG]	28 ... 16

CANopen[®] system data

Number of PDOs	6Tx/4Rx
Number of SDOs	1Tx/1Rx
Maximum number of digital input and output points	510
Maximum number of analog input and output points	254
Communication profile	DS-301 V3.0
Device profile	DS-401 V1.4

System limits of the bus coupler

Number of devices per station	63, maximum
Settable baud rates	10 kbaud, 20 kbaud, 50 kbaud, 125 kbaud, 250 kbaud, 500 kbaud, 1 Mbaud
Transmission speed on the local bus	500 kbps
Maximum power supply at U _L	2 A
Maximum power supply at U _{ANA}	0.5 A
Maximum power supply at U _S	8 A

System limits of the bus coupler

Maximum power supply at U_M	8 A
Maximum current consumption of the I/O modules	See terminal-specific data sheet



When configuring an Inline station, observe the current consumption of each device. The logic current consumption is indicated in each terminal-specific data sheet. The current consumption can differ depending on the individual terminal. If the maximum current carrying capacity of a potential jumper is reached, use an additional power terminal.

CANopen[®] interface

CAN bus, connected via 2 x 5-pos. TWIN-COMBICON connector; supply electrically isolated; shielding directly connected to functional earth ground

Common data for 24 V supplies U_{BK} , U_S , U_M

Connection	Via Inline connector
Connection technology	Spring-cage terminal blocks
Recommended cable lengths	30 m, maximum; do not route cable through outdoor areas
Continuation	Through potential routing
Special demands on the power supply	The U_M/U_S supplies are electrically isolated from the U_{BK} bus coupler supply, if they are supplied separately. This is only ensured if two separate power supply units are used.
Nominal value	24 V DC
Permissible range	19.2 V DC to 30 V DC (including all tolerances, ripple included)
Protective measures	
Surge voltage	Yes, suppressor diode
Polarity reversal	Yes, suppressor diode antiparallel to supply voltage



NOTE: Module damage when overloaded

Provide external fuses for each 24 V area. The power supply unit must be able to supply four times (400%) the nominal current of the external fuse, to ensure that the fuse blows safely in the event of an error.



The bus coupler supply U_{BK} generates the communications power U_L (7.5 V) and the analog supply U_{ANA} (24 V).

Notes on voltages U_L and U_{ANA}

Communications power U_L (7.5 V)	U_L is not electrically isolated from the 24 V bus coupler voltage U_{BK} . U_L is not electrically isolated from I/O voltages U_M and U_S . Communications power U_L is electronically short-circuit protected.
Analog supply U_{ANA} (24 V)	Decoupling of the 24 V input voltage by means of a diode. Smoothing via base frequency of 9.8 kHz and attenuation of 40 dB/decade. U_{ANA} is not electrically isolated from the 24 V bus coupler supply and the 7.5 V communications power.

Current consumption/power consumption

Current consumption from U_{BK} (24 V)	
Without connected I/O terminals	< 100 mA
With the maximum number of connected I/O terminals	1.25 A, maximum
Power supply at U_S (24 V) (total current with U_M)	8 A, maximum
Power supply at U_M (24 V) (total current with U_S)	8 A, maximum
Power dissipation of entire device	2.7 W, typical

Mechanical requirements

Vibration test; sinusoidal vibrations according to IEC 60068-2-6; EN 60068-2-6	5g load, 2 hours in each space direction
Shock test according to IEC 60068-2-27; EN 60068-2-27	30g load for 11 ms, half sinusoidal wave, three shocks in each space direction and orientation

Conformance with EMC directive 2004/108/EC**Noise immunity test according to EN 61000-6-2**

Electrostatic discharge (ESD)	EN 61000-4-2 / IEC 61000-4-2	Criterion B 6 kV contact discharge, 8 kV air discharge
Electromagnetic fields	EN 61000-4-3 / IEC 61000-4-3	Criterion A Field strength: 10 V/m
Fast transients (burst)	EN 61000-4-4 / IEC 61000-4-4	Criterion A All interfaces: 1 kV Criterion B All interfaces: 2 kV
Surge voltage	EN 61000-4-5 / IEC 61000-4-5	Criterion B DC supply lines: 0.5 kV/1 kV (symmetrical/asymmetrical) Fieldbus cable shield: 1 kV
Conducted interference	EN 61000-4-6 / IEC 61000-4-6	Criterion A Test voltage: 10 V

Noise emission test according to EN 61000-6-4

Noise emission of housing	EN 55011	Class A
---------------------------	----------	---------

Approvals

For the latest approvals, please visit phoenixcontact.net/products.

5 Tested successfully: Use under extreme ambient conditions

The terminal has been tested successfully over 250 temperature change cycles according to IEC 61131-2 in the range from -40°C to +70°C.

The following conditions were observed:

- The Inline devices for all connecting cables were connected with a minimum conductor cross section of 0.5 mm²
- The Inline station was installed on a wall-mounted horizontal DIN rail
- Fans were used to ensure continuous movement of air in the control cabinet
- The Inline station was not exposed to vibration or shock
- The Inline station was operated with a maximum of 24.5 V (ensured by using electronically regulated power supply units)

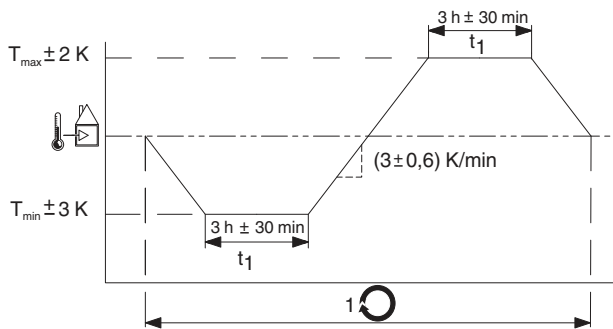

Figure 1 Temperature change cycle



Temperature in the control cabinet/ambient temperature



Cycle



WARNING:

The terminal is not approved for use in potentially explosive areas.

The terminal is not approved for use in safety technology.

6 Design of the bus coupler

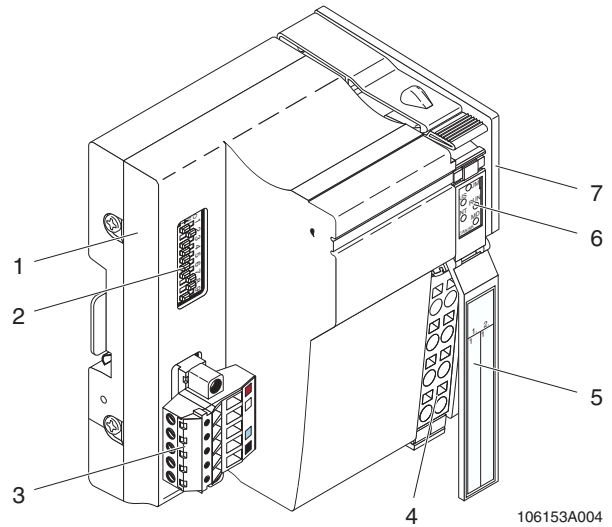

Figure 2 Inline CANopen® bus coupler

- 1 Electronics base
- 2 DIP switches for setting the address and baud rate
- 3 TWIN-COMBICON connector
- 4 Power connector
- 5 Labeling field
- 6 Diagnostic and status indicators
- 7 End plate

7 Terminal point assignment

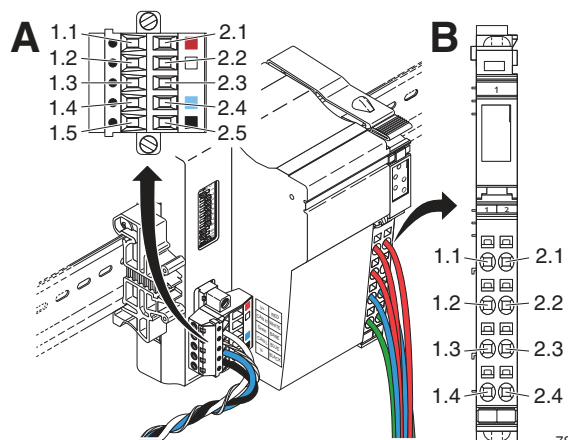

Figure 3 Terminal point assignment
A: 5-pos. network connector,
B: Power connector

7.1 Network connector

Terminal point	Marking		Assignment	Color in the network cable
1.1, 2.1	V+	RED	No connection	
1.2, 2.2	CAN H	WHITE	CAN H	White
1.3, 2.3	Drain	BARE	CAN shield	Bare
1.4, 2.4	CAN L	BLUE	CAN L	Blue
1.5, 2.5	V-	BLACK	CAN ground	Black



When the bus coupler is used in environments with heavy noise, Phoenix Contact recommends the following: Install a grounding terminal block to the left of the bus coupler and connect the network cable shield to this terminal. In this case, terminal point 1.3 of the network connector is not used.

7.2 Power connector

Terminal point	Assignment
1.1	Segment circuit U_S (+24 V DC)
1.2	Bus coupler supply U_{BK} (+24 V DC)
2.1, 2.2	Main circuit U_M (+24 V DC)
1.3	GND U_{BK}
2.3	GND U_M, U_S
1.4, 2.4	FE (functional earth ground)

7.3 Connection example

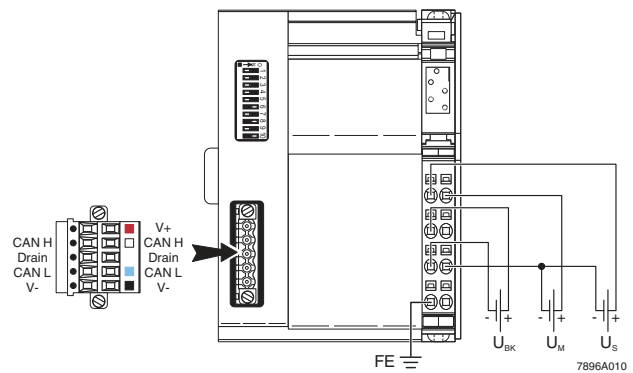

Figure 4 Typical bus coupler wiring



Terminal points 2.1 and 2.2 (U_M) are connected internally.
Terminal points 1.4 and 2.4 (FE) are connected internally.

7.4 Power supply of the bus coupler



NOTE: Module damage when overloaded

The maximum total current flowing through potential jumpers U_S , U_M and GND is 8 A.



NOTE: Malfunctions

Connect the bus coupler via one of the FE terminal points (1.4 or 2.4) on the power connector (see Figure 3). To do this, connect the FE terminal contact to a grounding terminal block via a 0.2 mm² to 1.5 mm² wire.

7.5 24 V segment supply (U_S) and 24 V main supply (U_M)

Both the segment supply and the main supply have the same reference potential. Therefore, an electrically isolated voltage area on the I/O side cannot be created without adding a power terminal.

The main supply and the segment supply are protected against polarity reversal and surge voltage.



NOTE: Module damage in the event of short-circuit

The main supply and segment supply do not have short-circuit protection.

The user must provide short-circuit protection. The rating of the fuse must be such that the maximum permissible load current is not exceeded.

7.6 24 V segment supply (U_S)

The segment voltage can be supplied at the bus coupler or a power terminal. There are several ways of providing the segment voltage at the bus coupler:

1. You can provide the segment voltage separately at terminal points 1.1 and 2.3 (GND) of the power connector.
2. Connections 1.1 and 2.1 or 2.2 can be jumpered to ensure the supply for the segment circuit from the main circuit.
3. A switch can be inserted between terminal points 1.1 and 2.1 or 2.2 to create a switched segment circuit (e.g., an emergency stop circuit).

7.7 24 V bus coupler supply (U_{BK})

The 24 V bus coupler supply generates the internal communications power U_L (supply of the connected Inline I/O modules with communications power) and the analog supply U_{ANA} . The use of a separate supply is recommended. The U_{BK} supply is protected against polarity reversal and surge voltage. This protects the power supply unit.



NOTE: Module damage in the event of short-circuit

The bus coupler supply does not have short-circuit protection.

The user must provide short-circuit protection. The rating of the fuse must be such that the maximum permissible load current is not exceeded.

8 Networking information

CANopen[®] has a linear bus topology (see Figure 5). A termination resistor is required at each end of the trunk line. Branch lines are permitted but should be as short as possible (0.3 m at 1 Mbaud).

The total length of trunk and branch lines depends on the data rate and the type of cable. The guide values listed in the tables in Section 8.2 "Branch line" can be used to determine the type of trunk line, the length, the termination resistors and number of devices. For detailed information on the cable length of trunk and branch lines, please refer to CANopen[®] specification DR303-1.

8.1 Trunk line

If there are no branch lines in the network, the trunk line is used to connect the devices. If branch lines are present, T-connectors will be linked via the trunk line (see Figure 5). The maximum number of devices within the CANopen[®] network is limited to 127. The maximum length of the trunk line ranges from 40 m to 1 km, depending on the baud rate. The total length of the cables can be extended by using repeaters.

8.2 Branch line

The branch line is used to connect devices to the trunk line. They are connected using a T-connector. However, please observe the recommended length of the branch lines, especially at higher baud rates. At 1 Mbit, the maximum length of a branch line is 0.3 m.

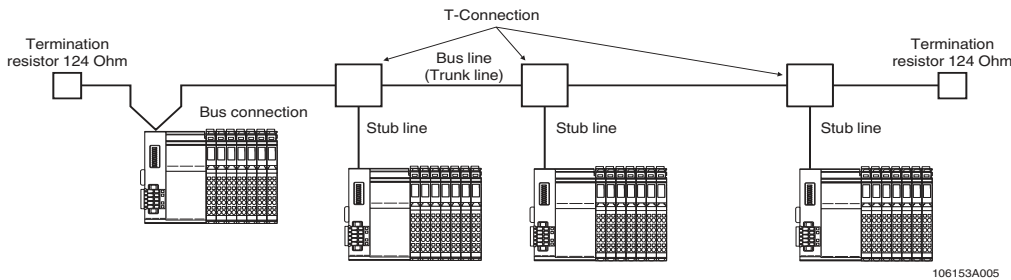

Figure 5 CANOpen® example topology

Cable length/type vs. baud rate

Bus cable length (meters)	mΩ per meter	Cable cross-section (mm ²)	Termination resistor (Ω)	Baud rate (kbit)
0 to 40	70	0.25 to 0.34	124	1000 at 40 m
40 to 300	<60	0.34 to 0.60	150 to 300	>500 at 100 m
300 to 600	<40	0.50 to 0.60	150 to 300	>100 at 500 m
600 to 1000	<26	0.75 to 0.80	150 to 300	>50 at 1km



Note: Recommended bus cable parameters for alternating current: 120 Ω impedance with 5 ns/m line delay.

Cable length/type vs. number of nodes

Cable cross-section (mm ²)	Maximum length in meters (0.2 safety margin)			Maximum length in meters (0.1 safety margin)		
	32 nodes	64 nodes	100 nodes	32 nodes	64 nodes	100 nodes
0.25	200	170	150	230	200	170
0.50	360	310	270	420	360	320
0.75	550	470	410	640	550	480

8.3 Termination resistors

CANOpen® requires a termination resistor to be installed at each end of the trunk line. A typical termination resistor at the end of a CANOpen® trunk line has a resistance of 124 Ω and a power dissipation of 0.25 W. For the precise values and additional information about termination resistors, please refer to CANOpen® specification DR303-1.

9 DIP switch settings for address and baud rate

Each bus coupler has ten DIP switches. The DIP switches are located on the left side of the CANopen® bus coupler (see Figure 6). DIP switches 1 to 7 are used to set the device address, DIP switches 8 to 10 are used to set the baud rate.

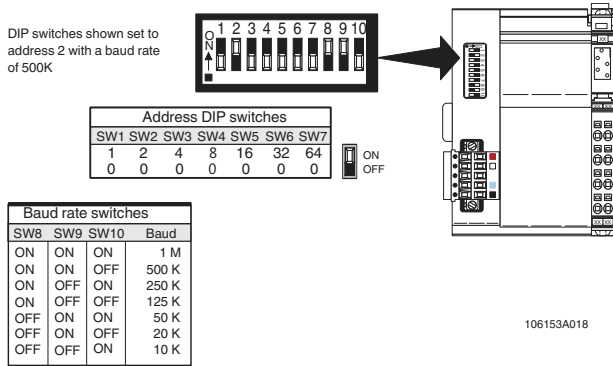

Figure 6 Meaning of the DIP switches

9.1 Setting the device address

The device address is set using DIP switches 1 to 7. DIP switch 1 is the least significant digit of the device address and DIP switch 7 the most significant digit. Valid device address settings range from 1 to 127. Note that the U_{BK} supply will need to be restarted in order to implement any changes to the device address. Device address 0 is reserved and is used to auto-configure the I/O connected to the module. The module will not be switched on with the address set to 0.

9.2 Setting the baud rate using DIP switches 8, 9, and 10

The baud rate is set using DIP switches 8 to 10. Figure 6 shows DIP switch settings for various baud rates.



Note that the U_{BK} supply will need to be restarted in order to implement any changes to the baud rate.

10 Configuring the bus coupler using the DIP switches

Auto-configuration using the DIP switches allows for “in-the-field” configuration of the bus coupler without any software. The following default settings are used:

1. Receive Process Data Object (RPDO) 1 contains the digital outputs from 1 to 64. If there are less digital outputs connected, the RPDO will contain the outputs from 1 to the number of connected digital outputs.
2. Transmit Process Data Object (TPDO) 1 contains the digital inputs from 1 to 64. If there are less digital inputs connected, the TPDO will contain the inputs from 1 to the number of connected digital inputs.
3. RPDO 2 contains the analog outputs from 1 to 4, if they are present.
4. TPDO 2 contains the analog inputs from 1 to 4, if they are present.
5. RPDO 3 contains the analog outputs from 5 to 8, if they are present.
6. TPDO 3 contains the analog inputs from 5 to 8, if they are present.
7. RPDO 4 contains the analog outputs from 9 to 12, if they are present.
8. TPDO 4 contains the analog inputs from 9 to 12, if they are present.



All other I/O modules will not be mapped during configuration. This also includes the special function modules. All unmapped I/O modules must be manually mapped to PDO 5 to PDO 32.

Inline function modules include the following module types:

- IB IL SSI — Absolute encoder
- IB IL INC — Incremental encoder
- IB IL CNT — High-speed counter
- ASI MA IB IL — Inline-to-AS-i controller
- IB IL RS 232 — RS-232 module
- IB IL RS 485/422 — RS-485/422 module

10.1 Configuration procedure

For auto-configuration, proceed as follows:

1. Set DIP switches 1 to 7 of the device address to 0.
2. Switch on the bus coupler (U_{BK} , U_S , and U_M supplies) with all required I/O modules. If the RUN LED on the bus coupler is permanently on (green), the I/O configuration is stored in the station flash memory.



The module will not be switched on with the address set to 0.

3. Switch off the bus coupler.
4. Set the desired switch settings for both the device address and the baud rate.
5. Switch on the bus coupler.

11 Diagnostics

11.1 Diagnostics indicators (LEDs)

See 12 "Diagnostic and status indicators"

11.2 Alarm message and diagnostic object indices



For further details on the following explanation, please refer to the UM EN IL CAN BK-TC-PAC user manual.

Diagnostic information is made available by means of several methods. The alarm message and the Service Data Objects (SDOs) enable reading of the status of the Inline station.

- Alarm message
In the CANopen[®] bus coupler, an alarm message is generated when a fault occurs. This alarm message contains the Inline status and the number of the faulty module along with other useful information.
- Error Register object index (1001_{hex})
This object index can be used to receive the manufacturer-specific bit 7 using a Service Data Object (SDO). Bit 7 indicates an error in the Inline station. Using this bit or an alarm message allows the user to retrieve further diagnostic information.
- Manufacturer Status Register object index(1002_{hex})
Manufacturer-specific status of the Inline station and the number of the faulty Inline module are available.
- Predefined Error Field object index (1003_{hex})
This object index reads up to the last ten errors (subindex). Subindex 0 indicates the total number of available errors in the "stack".

- Inline Station Status object index (3101_{hex})
This object index indicates the current status of the Inline station, (error code, see Figure 8).
- Inline Faulted Module Number object index (3102_{hex})
This object index indicates the current number of the faulty Inline module.
- Inline Latched Fault object index (310C_{hex})
Latches and indicates the last Inline station status (low byte). This object index has the same bit meaning as the Inline Station Status object index (3101_{hex}) except that the bits are latched.
- Inline Latched Faulted Module object index (310D_{hex})
Latches and indicates the number of the last faulty Inline module. This object index has the same bit meaning as the Inline Faulted Module object index (3103_{hex}) except that the module number is latched.



In the operational state, a fault within the Inline station will always generate an alarm message. By default, due to the settings of the fault bits, pre-programmed fault data (zero by default) will be sent to the local outputs. It is possible that diagnostic information may be overwritten due to intermittent error conditions. In such cases, it is recommended to access the Predefined Error Field object index (1003_{hex}). Each subindex in this object index (1003_{hex}) represents a stored fault sequence.

12 Diagnostic and status indicators

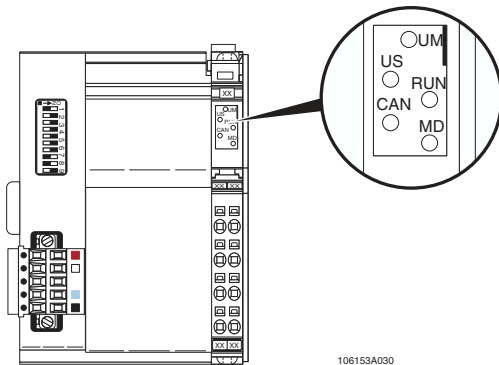

Figure 7 Diagnostic and status indicators

LED		Meaning
CAN	Red/green	CANopen® status
	ON (green):	“Operational” state: The device is ready to operate.
	2 Hz (medium) flashing (green):	“Pre-operational” state: No PDO transmission possible.
	0.5 Hz (slow) flashing (green):	“Stopped” state: Failsafe state; no PDO transmission possible.
	ON (red):	CAN controller is not connected to the bus.
	One flash (red):	At least one error counter has reached the warning level.
	Two flashes (red):	A guard event or heartbeat event has been triggered.
	Three flashes (red):	Sync timeout error.
	OFF:	Supply voltage U _{BK} is missing or module in reset state.
MD	Green/red LED	Module status
	ON (green)	Device is ready to operate.
	ON (green/red)	Self test/read local bus.
	ON (red)	Serious error, replace device.
	Flashing (red)	Minor error (e.g., DO short circuit).
	OFF	Supply voltage U _{BK} is missing or module in reset state.
RUN	LED (multi-color)	Backplane communication status
	ON (green)	Local bus is running data cycles.
	Flashing (green)	I/O error (1 Hz)
	ON (red)	Local bus stopped
	ON (red/yellow-orange)	Configuration mismatch
	ON (green/yellow-orange)	Preprogrammed error values are being written to the outputs.
	OFF	Supply U _{BK} not present
US	LED (green)	Segment supply
	ON/OFF	Segment supply present/not present
UM	LED (green)	Main supply
	ON/OFF	Main supply present/not present

13 Inline fault control

Objects 1029_{hex} and 3002_{hex} to 300A_{hex} enable output behavior control in the event of various faults.

- Object 1029_{hex} controls what mode the module will be put in during a communication fault.
- Objects 3003_{hex} to 300A_{hex} determine the CANopen[®] state depending on specific fault types.
- Object 3002_{hex} is used to determine how the bus coupler will control the outputs when specific faults occur. There are four modes available for controlling the outputs. Each mode is defined in the following.

13.1 Inline fault mode 0: Stop running data cycles on fault

The outputs are turned OFF automatically if a local fault occurs.

13.2 Inline fault mode 1: Auto restart (default)

The outputs are turned OFF automatically if a local fault occurs. They remain in a waiting state until the fault has been corrected. Once the fault has been removed the outputs can be controlled.

Bit 7	Bit 6	Bit 5	Bit 4	Bit 3	Bit 2	Bit 1	Bit 0
Reserved	Faulted cycles mode	Inlineconnecti on fault	Local bus inactive fault	Module change fault	Power fault	Peripheral fault	CRC fault

Figure 8 Inline station status, object index 3101_{hex}, bit meanings

13.3 Inline fault mode 2: Go to fault state

The outputs are turned OFF automatically for up to two seconds if a local fault occurs. After two seconds, the station will always set the outputs to the preprogrammed CANopen[®] fault states.

13.4 Inline fault mode 3: Continue on fault

The outputs are turned OFF automatically for up to two seconds if a local fault occurs. After two seconds, the station will perform an update for all remaining active I/O modules.

13.5 Fault states

The bus coupler supports the standard CANopen[®] digital and analog outputs, fault modes and values.

- Digital output support:
Hold last state,
turn off during a fault condition (default),
turn on during a fault condition
- Analog output support:
Hold last value,
set to value determined by the error value object

14 Supported object indices

For a detailed description of the objects listed in the following sections, please refer to the UM EN IL CAN BK-TC-PAC user manual. Some of the abbreviations used are:

RO	Read only
const	Constant
M	Mandatory
O	Optional
C	Conditional
RW	Read/write
RWW	Read/write and can be mapped into a receive process data object

14.1 Object dictionary entries for communication

Standard objects

Index (hex)	Object	Name	Data type	Access	M/O
1000	VAR	Device type	UNSIGNED32	RO	M
1001	VAR	Error register	UNSIGNED8	RO	M
1002	VAR	Manufacturer status register	UNSIGNED32	RO	O
1003	VAR	Predefined error field	UNSIGNED32	RO	O
1005	VAR	COB-ID SYNC	UNSIGNED32	RW	O
1008	VAR	Manufacturer device name	Vis-String	const	O
1009	VAR	Manufacturer hardware version	Vis-String	const	O
100A	VAR	Manufacturer software version	Vis-String	const	O
100C	VAR	Guard time	UNSIGNED16	RW	O
100D	VAR	Life time factor	UNSIGNED8	RW	O
1010	ARRAY	Store parameters	UNSIGNED32	RW	O
1011	ARRAY	Restore default parameters	UNSIGNED32	RW	O
1012	VAR	COB-ID TIME	UNSIGNED32	RW	O
1014	VAR	COB-ID EMCY	UNSIGNED32	RW	O
1015	VAR	Inhibit time EMCY	UNSIGNED16	RW	O
1016	ARRAY	Consumer heartbeat time	UNSIGNED32	RW	O
1017	VAR	Producer heartbeat time	UNSIGNED16	RW	O
1018	RECORD	Identity Object	Identity (23h)	RO	M
1020	ARRAY	Verify Configuration	UNSIGNED32	RW	O
1027	ARRAY	Module List	UNSIGNED16	RO	O
1029	ARRAY	Error Behavior	UNSIGNED8	RW	O

Server SDO parameters

Index (hex)	Object	Name	Data type	Access	M/O
1200	RECORD	1 st Server SDO parameter	SDO Par. (22 _{hex})	RO	O
1201	RECORD	2 nd Server SDO parameter	SDO Par. (22 _{hex})	RW	O

Client SDO parameters

Not Supported

Receive PDO communication parameters

Index (hex)	Object	Name	Data type	Access	M/O
1400	RECORD	1 st receive PDO Par.	PDO CommPar (20 _{hex})	RW	M/O
1401	RECORD	2 nd receive PDO Par.	PDO CommPar (20 _{hex})	RW	M/O
...
141F	RECORD	32 nd receive PDO Par.	PDO CommPar (20 _{hex})	RW	M/O

Receive PDO mapping parameters

Index (hex)	Object	Name	Data type	Access	M/O
1600	RECORD	1 st receive PDO	PDO Mapping (21 _{hex})	RW	M/O
1601	RECORD	2 nd receive PDO	PDO Mapping (21 _{hex})	RW	M/O
...
161F	RECORD	32 nd receive PDO	PDO Mapping (21 _{hex})	RW	M/O

Transmit PDO communication parameters

Index (hex)	Object	Name	Data type	Access	M/O
1800	RECORD	1 st transmit PDO Par.	PDO CommPar (20 _{hex})	RW	M/O
1801	RECORD	2 nd transmit PDO Par.	PDO CommPar (20 _{hex})	RW	M/O
...
181F	RECORD	32 nd transmit PDO Par.	PDO CommPar (20 _{hex})	RW	M/O

Transmit PDO mapping parameters

Index (hex)	Object	Name	Data type	Access	M/O
1A00	RECORD	1 st transmit PDO	PDO Mapping (21 _{hex})	RW	M/O
1A01	RECORD	2 nd transmit PDO	PDO Mapping (21 _{hex})	RW	M/O
...
1A1F	RECORD	32 nd transmit PDO	PDO Mapping (21 _{hex})	RW	M/O

14.2 Manufacturer-specific I/O objects

Index (hex)	Object	Name	Data type	Access
2000	ARRAY	DIP Latch Enable 8-Bit	UNSIGNED8	RW
2001	ARRAY	DIP Latch State 8-Bit	UNSIGNED8	RW
2400	ARRAY	AIP Range	UNSIGNED16	RW
2410	ARRAY	AOP Response Data	UNSIGNED16	RW

14.3 Inline configuration objects

Index (hex)	Object	Name	Data type	Access
3000	VAR	Reconfigure I/O	BOOLEAN	RW
3002	VAR	Fault Mode	UNSIGNED8	RW
3003	VAR	CRC Fault Mode	UNSIGNED8	RW
3004	VAR	PF Fault Mode	UNSIGNED8	RW
3005	VAR	Power Fault Mode	UNSIGNED8	RW
3006	VAR	Module Change Fault Mode	UNSIGNED8	RW
3007	VAR	Local Bus Inactive Fault Mode	UNSIGNED8	RW
3008	VAR	Connection Fault Mode	UNSIGNED8	RW
3009	VAR	Faulted Cycles Fault Mode	UNSIGNED8	RW
300A	VAR	Processor Power Fault Mode	UNSIGNED8	RW
300F	VAR	Erase Configuration	BOOLEAN	RW

14.4 Inline interface objects

Index (hex)	Object	Name	Data type	Access
3100	VAR	Baud Rate	UNSIGNED8	RO
3101	VAR	Station Status	UNSIGNED16	RO
3102	VAR	Faulted Module	UNSIGNED8	RO
3103	VAR	Retry Max	UNSIGNED8	RW
3104	VAR	Number Modules	UNSIGNED8	RO
3105	VAR	Count of Bits	UNSIGNED16	RO
3106	VAR	Count of Bytes	UNSIGNED16	RO
3109	VAR	Loop Diagnostic Count	UNSIGNED16	RO
310A	VAR	Faulted Module (Before Break)	UNSIGNED8	RO
310B	VAR	Faulted Module (After Break)	UNSIGNED8	RO
310C	VAR	Latched Fault	UNSIGNED8	RO
310D	VAR	Latched Faulted Module	UNSIGNED8	RW
310E	VAR	Latched Faulted Module (Before Break)	UNSIGNED8	RO
310F	VAR	Latched Faulted Module (After Break)	UNSIGNED8	RO
3110	VAR	Inline Power Status	UNSIGNED8	RO
3111	VAR	Inline Control Byte	UNSIGNED8	RW

14.5 Inline module objects

Index (hex)	Object	Name	Data type	Access
3200	ARRAY	Stored Module ID	UNSIGNED16	RO
3201	ARRAY	Current Module ID	UNSIGNED16	RO
3202	ARRAY	IN Data COP Index	UNSIGNED16	RO
3203	ARRAY	IN Data COP First Subindex	UNSIGNED8	RO
3204	ARRAY	IN Data COP Last Subindex	UNSIGNED8	RO
3205	ARRAY	OUT Data COP Index	UNSIGNED16	RO
3206	ARRAY	OUT Data COP First Subindex	UNSIGNED8	RO
3207	ARRAY	OUT Data COP Last Subindex	UNSIGNED8	RO

14.6 Inline special function module objects

Index (hex)	Object	Name	Data type	Access
3300	ARRAY	Special Func. Data Size	UNSIGNED8	RO
3301	ARRAY	Special Func. Status	BOOLEAN	RO
3302	ARRAY	Special Func. Data In (1 Byte)	UNSIGNED8	RO
3303	ARRAY	Special Func. Data Out (1 Byte)	UNSIGNED8	RWW
3304	ARRAY	Special Func. Data In (2 Bytes)	UNSIGNED16	RO
3305	ARRAY	Special Func. Data Out (2 Bytes)	UNSIGNED16	RWW
3306	ARRAY	Special Func. Data In (3 Bytes)	UNSIGNED24	RO
3307	ARRAY	Special Func. Data Out (3 Bytes)	UNSIGNED24	RWW
3308	ARRAY	Special Func. Data In (4 Bytes)	UNSIGNED32	RO
3309	ARRAY	Special Func. Data Out (4 Bytes)	UNSIGNED32	RWW
330A	ARRAY	Special Func. Data In (6 Bytes)	UNSIGNED48	RO
330B	ARRAY	Special Func. Data Out (6 Bytes)	UNSIGNED48	RWW
330C	ARRAY	Special Func. Data In (8 Bytes)	UNSIGNED64	RO
330D	ARRAY	Special Func. Data Out (8 Bytes)	UNSIGNED64	RWW
330E	ARRAY	Special Func. Data In (>8 Bytes)	UNSIGNED8	RO
330F	ARRAY	Special Func. Data Out (>8 Bytes)	UNSIGNED8	RWW

14.7 Digital input objects

Index (hex)	Object code	Name	Data type	Category
6000	ARRAY	Read Input 8-Bit	UNSIGNED8	C: DI
6005	VAR	Global Int. Enable Dig.	BOOLEAN	O
6006	ARRAY	Int. Mask Any Change 8-Bit	UNSIGNED8	O
6100	ARRAY	Read Input 16-bit	UNSIGNED16	O
6106	ARRAY	Int. Mask Any Change 16-Bit	UNSIGNED16	O
6120	ARRAY	Read Input 32-bit	UNSIGNED32	O
6126	ARRAY	Int. Mask Any Change 32-Bit	UNSIGNED32	O

14.8 Digital output objects

Index (hex)	Object	Name	Data type	Category
6200	ARRAY	Write Output 8-Bit	UNSIGNED8	C: DO
6206	ARRAY	Error Mode Output 8-Bit	UNSIGNED8	O
6207	ARRAY	Error State Output 8-Bit	UNSIGNED8	O
6300	ARRAY	Write Output 16-Bit	UNSIGNED16	O
6306	ARRAY	Error Mode Output 8-Bit	UNSIGNED16	O
6307	ARRAY	Error State Output 8-Bit	UNSIGNED16	O
6320	ARRAY	Write Output 32-Bit	UNSIGNED32	O
6326	ARRAY	Error Mode Output 32-Bit	UNSIGNED32	O
6227	ARRAY	Error State Output 32-Bit	UNSIGNED32	O

14.9 Analog input objects

Index (hex)	Object	Name	Data type	Category
6400	ARRAY	Read Analog Input 8-Bit	INTEGER8	O
6401	ARRAY	Read Analog Input 16-Bit	INTEGER16	C: AI

14.10 Analog output objects

Index (hex)	Object	Name	Data type	Category
6410	ARRAY	Write Analog Output 8-Bit	INTEGER8	O
6411	ARRAY	Write Analog Output 16-Bit	INTEGER16	C: AO

14.11 Analog input configuration objects

Index (hex)	Object	Name	Data type	Category
6421	ARRAY	AI Int. Trigger Selection	UNSIGNED8	O
6423	VAR	AI Global Int. Enable	Boolean	C: AI
6424	ARRAY	AI Int. Upper Limit Integer	INTEGER32	O
6425	ARRAY	AI Int. Lower Limit Integer	INTEGER32	O
6426	ARRAY	AI Int. Delta Unsigned	UNSIGNED32	O

14.12 Analog output configuration objects

Index (hex)	Object	Name	Data type	Category
6443	ARRAY	Analog Output Error Mode	UNSIGNED8	O
6444	ARRAY	Analog Output Error Value	INTEGER32	O

14.13 PCP interface objects

Index (hex)	Object	Name	Data type	Category
3400	ARRAY	PCP PDU Size	UNSIGNED8	RO
3401	ARRAY	PCP PCP Size	UNSIGNED8	RO
3402	ARRAY	PCP Status	UNSIGNED8	RO
3403	ARRAY	PCP Request	DOMAIN	RW
3404	ARRAY	PCP Response	DOMAIN	RO
3405	ARRAY	PCP Module	UNSIGNED8	RW
3406	ARRAY	PCP Write Index	UNSIGNED16	RW
3407	ARRAY	PCP Write Subindex	UNSIGNED8	RW
3408	ARRAY	PCP Write Data	DOMAIN	RW
3409	ARRAY	PCP Read Index	UNSIGNED16	RW
340A	ARRAY	PCP Read Subindex	UNSIGNED8	RW
340B	ARRAY	PCP Read Data	DOMAIN	RO
340C	ARRAY	PCP Request Fragment	PCP_FRAG_REQUEST	RW
340C	ARRAY	PCP Response Fragment	PCP_FRAG_RESPONSE	RO
340D	ARRAY	PCP Write Invoke ID	UNSIGNED8	RW
340E	ARRAY	PCP Read Invoke ID	UNSIGNED8	RW
340F	ARRAY	PCP Write Data Confirmation	DOMAIN	RO
34010	ARRAY	PCP Read Data Confirmation	DOMAIN	RO