

LOOSE PIECE		TAPE MOUNTED		SPECIFICATIONS						
MATERIAL NUMBER	ENGINEERING NUMBER	MATERIAL NUMBER	ENGINEERING NUMBER	STUD SIZE	"S" ±.005 [0.13]	"W" ±.010 [0.25]	"C" MIN.	"L" MAX.	"H"	STOCK ±.001 [0.025] THICKNESS
190560055	B-318-14	---	---	14	.265 [6.73]	.534 [13.56]	.554 [14.07]	1.115 [28.32]	---	.031 [0.79]
190560057	B-318-38	---	---	38	.390 [9.91]					
190560059	B-318-56	---	---	56	.328 [8.33]					
190560063	B-323-04	---	---	4	.119 [3.02]	.250 [6.35]	.209 [5.31]	.639 [16.23]	.980 [24.89]	.031 [0.79]
190560065	B-323-06	190560067	B-323-06T	6	.146 [3.71]					
190560068	B-323-08	---	---	8	.173 [4.39]					
190560070	B-325-10	---	---	10	.198 [5.03]	.467 [11.86]	.388 [9.86]	.916 [23.27]	.980 [24.89]	.031 [0.79]
190560072	B-325-14	190560074	B-325-14T	14	.265 [6.73]					
190560075	B-325-56	---	---	56	.328 [8.33]					
190560102	B-337-04	---	---	4	.119 [3.02]	.312 [7.92]	.285 [7.24]	.730 [18.54]	.980 [24.89]	.031 [0.79]
190560104	B-337-06	---	---	6	.146 [3.71]					
190560106	B-337-08	190560108	B-337-08T	8	.173 [4.39]					
190560109	B-337-10	190560111	B-337-10T	10	.198 [5.03]					
190560114	B-339-06	---	---	6	.146 [3.71]	.342 [8.69]	.310 [7.87]	.775 [19.69]	---	.031 [0.79]
190560116	B-339-08	---	---	8	.173 [4.39]					
190560118	B-339-10	---	---	10	.198 [5.03]					

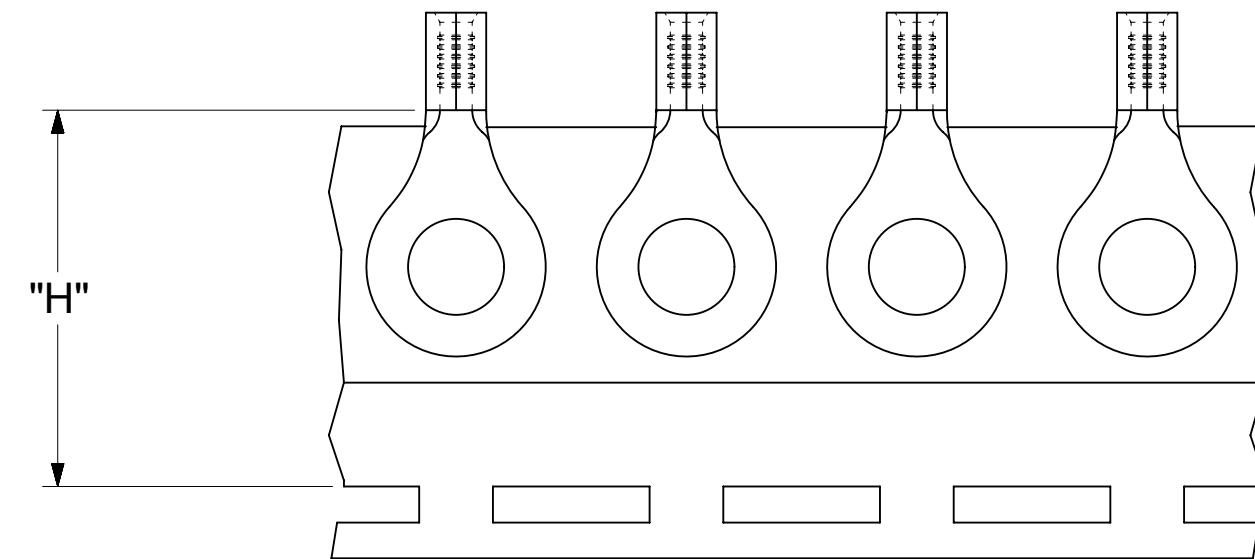
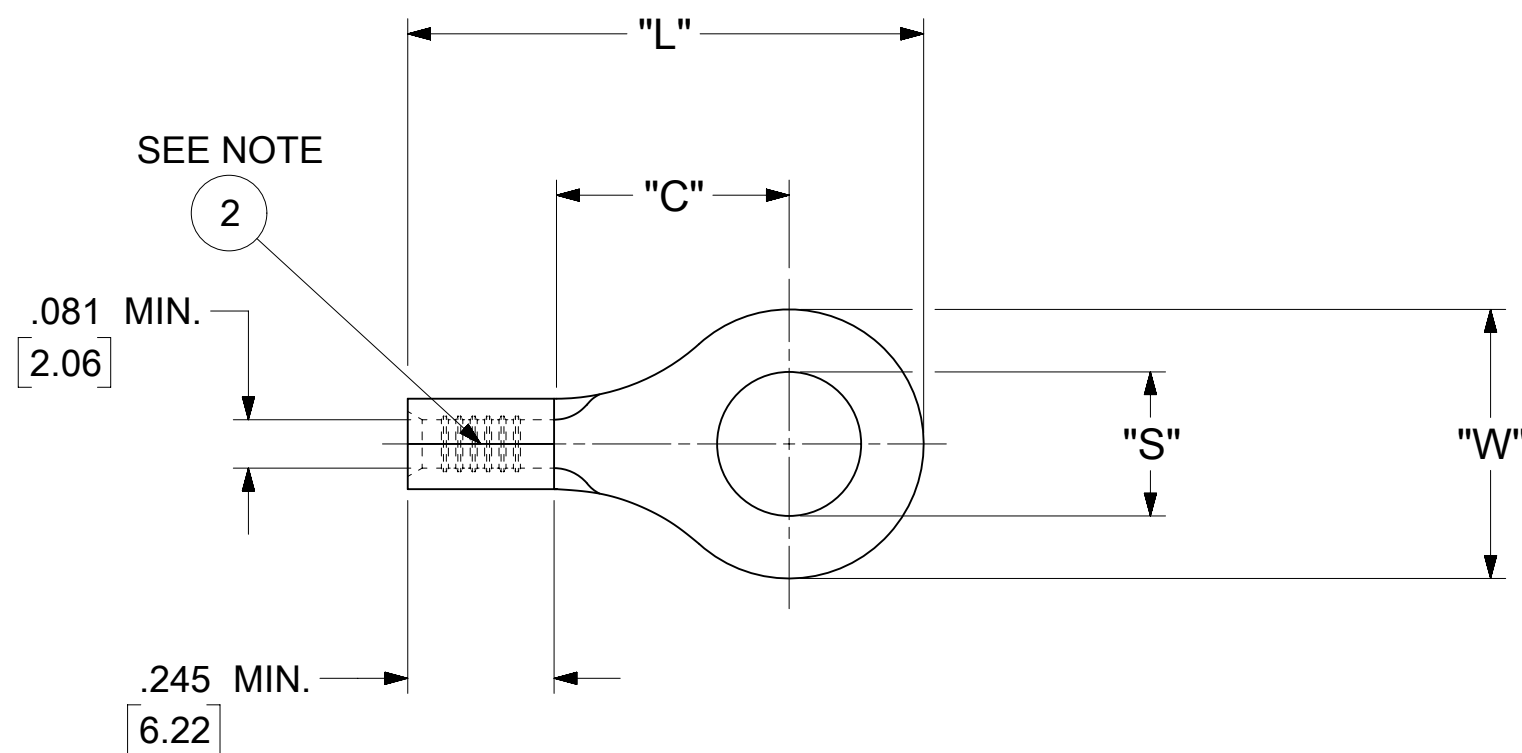

PARTS ON TAPE

NOTES:

- MATERIAL: COPPER
PLATING: ELECTRO-TIN (.0003 MIN).
- BRAZED SEAM
- WIRE SIZE: 16-14 AWG
1.0-2.5 MM²
- ALL DIMENSIONS IN INCHES/[MM].
- PARTS ARE ROHS COMPLIANT.
- DIMS. SHOWN ARE FOR REFERENCE ONLY.

SYMBOLS	THIS DRAWING CONTAINS INFORMATION THAT IS PROPRIETARY TO MOLEX ELECTRONIC TECHNOLOGIES, LLC AND SHOULD NOT BE USED WITHOUT WRITTEN PERMISSION										
	DIMENSION UNITS	SCALE		CURRENT REV DESC: MIGRATION TO ECTR/NX							
▽ = 0	INCH/MM	NTS		EC NO: 620952							
▽ = 0	GENERAL TOLERANCES (UNLESS SPECIFIED)			DRWN: ABENJAMINLW 2019/06/13						VERSAKRIMP 300-SERIES	
▽ = 0		MM	INCH	CHK'D: GROJAS01 2019/07/19						PRODUCT CUSTOMER DRAWING	
▽ = 0	4 PLACES	± ---	± ---	APPR: JMACNEIL 2019/08/05						DOCUMENT NUMBER	
▽ = 0	3 PLACES	± ---	± .005	INITIAL REVISION:						DOC TYPE	
▽ = 0	2 PLACES	± 0.13	± .01	DRWN: JJ 1984/11/28						DOC PART	
▽ = 0	1 PLACE	± 0.25	± ---	APPR: JMACNEIL 2019/08/05						REVISION	
▽ = 0	0 PLACES	± ---	± ---	DRAFT WHERE APPLICABLE MUST REMAIN WITHIN DIMENSIONS						190560053	
▽ = 0	ANGULAR TOL	± 0.5 °		THIRD ANGLE PROJECTION		DRAWING		SERIES		MATERIAL NUMBER	
▽ = 0				C-SIZE		19056		CUSTOMER		SHEET NUMBER	
								GENERAL MARKET		1 OF 1	

NOTES:

- ① MAT'L: COPPER (STOCK TKN. $\frac{.031}{.79}$)
PLATING: ELECTRO-TIN (.0003 MIN.)
- ② BRAZED SEAM

STUD SIZES: ($\pm .005$)

- 02 = .094
- 04 = .119
- 06 = .146
- 08 = .173
- 10 = .198
- 14 = .265
- 56 = .328
- 38 = .390

"UL" LISTING # E32244
"CSA" LISTING # 18689

ALL DIMENSIONS = INCHES
M

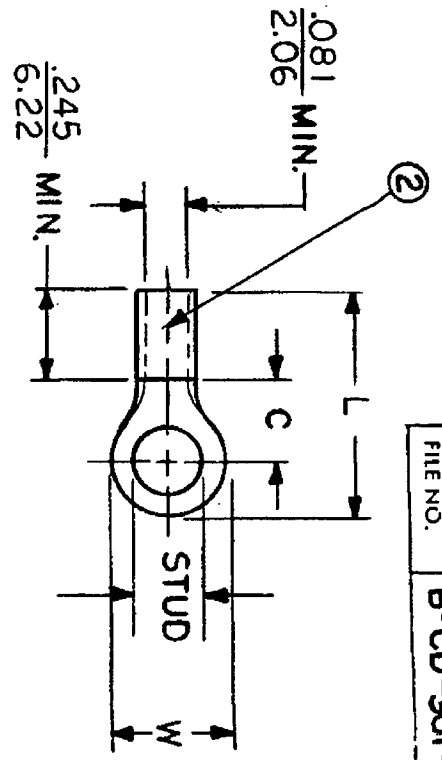

FILE NO. B-CD-301-01

WIRE SIZE: 16-14 AWG
1.0-2.5 MM²

PART NUMBER	"W" $\pm .010$	"C" MIN.	"L" MAX.	AVAILABLE STUD SIZES
B-318-	$\frac{.534}{13.56}$	$\frac{.554}{14.07}$	$\frac{1.115}{28.32}$	10, 14, 56, 38
B-323-	$\frac{.250}{6.35}$	$\frac{.209}{5.31}$	$\frac{.639}{16.23}$	02, 04, 06, 08
B-325-	$\frac{.467}{11.86}$	$\frac{.388}{9.86}$	$\frac{.916}{23.27}$	10, 14, 56
B-337-	$\frac{.312}{7.92}$	$\frac{.285}{7.24}$	$\frac{.730}{18.54}$	04, 06, 08, 10
B-339-	$\frac{.342}{8.69}$	$\frac{.310}{7.87}$	$\frac{.775}{19.69}$	04, 06, 08, 10

DIMENSIONAL TOLERANCES UNLESS OTHERWISE SPECIFIED		REFERENCE	SCALE: NTS	DATE	TITLE:
FRAC.	DEC.	ANG.	DRWN. BY: JJ	11/28/84	RING TONGUE TERMINAL
\pm	\pm	\pm	CHKD. BY: GZ	11/30/84	VERSAKRIMP 300-SERIES
			APPRD. BY:		



DWG. NO. A CUSTOMER DWG.