

QUICK START GUIDE FOR DEMONSTRATION CIRCUIT 644 HIGH LINEARITY UPCONVERTING MIXER

LT5520

DESCRIPTION

Demonstration circuit 644 is an upconverting mixer featuring the LT[®]5520. The LT[®]5520 is a 1.3GHz to 2.3GHz High Linearity Upconverting Mixer optimized for wireless and cable infrastructure applications. A high-speed, internally matched LO amplifier drives a double-balanced mixer core, allowing the use of a low power, single-ended LO source.

An RF output transformer is integrated, thus eliminating the need for external matching components at the RF out-

put, while reducing system cost, component count, board area, and system-level variations.

The IF port can be easily matched to a broad range of frequencies for use in many different applications.

Demonstration circuit 644 is designed for an RF output frequency range from 1.3GHz to 2.3GHz and is optimized for a 140MHz IF input frequency.

Design files for this circuit board are available. Call the LTC factory.

Table 1. Typical Performance Summary (T_A = 25°C)

PARAMETER	CONDITION (f _{IF} = 140MHz, f _{LO} = 1760MHz)	VALUE
Supply Voltage		4.5V to 5.25V
Supply Current	V _{CC} = 5V, EN = High	60mA
Maximum Shutdown Current	V _{CC} = 5V, EN = Low	100μA
Frequency Range		1.3GHz to 2.3GHz
IF Input Return Loss	Z ₀ = 50 Ω, with external matching	20dB
LO Input Return Loss	Z ₀ = 50 Ω	16dB
RF Input Return Loss	Z ₀ = 50 Ω	20dB
LO Input Power		-10dBm to 0dBm
Conversion Gain	P _{IF} = -10dBm, P _{LO} = -5dBm	-1dB
SSB Noise Figure	P _{LO} = -5dBm	15dB
Input 3 rd Order Intercept	2-Tone, -10dBm/Tone, Δf = 1MHz, P _{LO} = -5dBm	15.9dBm
Input 2 nd Order Intercept	1-Tone, -10dBm, P _{LO} = -5dBm	45dBm
Input 1dB Compression	P _{LO} = -5dBm	4dBm
LO to RF leakage	P _{LO} = -5dBm	-41dBm
LO to IF leakage	P _{LO} = -5dBm	-35dBm
IF Common Mode Voltage	Internally biased	1.77V

QUICK START GUIDE FOR DEMONSTRATION CIRCUIT 644

HIGH LINEARITY UPCONVERTING MIXER

APPLICATION NOTE

FREQUENCY RANGE

Demonstration circuit 644 is optimized for an IF input frequency of 140MHz. This frequency is set by the input IF matching components on the PCB. Other values may be used to maintain best performance for IF frequencies ranging from 10MHz to 500MHz.

CURRENT CONSUMPTION

If lower power consumption is required, the LT5520's supply current can be reduced by increasing the value of

the DC return resistors, R1, R2. Operation at a lower supply current will, however, degrade linearity.

LO TO RF LEAKAGE

Minimum LO to RF leakage is realized when R1 & R2 are closely matched; 0.1% tolerance resistors are recommended for this reason. Resistors with a greater tolerance (ie; 1%) may be used with some degradation of LO to RF leakage.

QUICK START PROCEDURE

Demonstration circuit 644 is easy to set up to evaluate the performance of the LT5520. Refer to Figure 1 for proper measurement equipment setup and follow the procedure below:

NOTE:

- a. Use high performance signal generators with low harmonic output for 2nd & 3rd order distortion measurements. Otherwise, low-pass filters at the signal generator outputs should be used to suppress harmonics, particularly the 2nd harmonic.
 - b. High quality combiners that provide a 50 ohm termination on all ports and have good port-to-port isolation should be used. Attenuators on the outputs of the signal generators are recommended to further improve source isolation and to reduce reflection into the sources.
1. Connect all test equipment as shown in Figure 1.
 2. Set the DC power supply's current limit to 70mA, and adjust output voltage to 5V.
 3. Connect Vcc to the 5V DC supply, and then connect EN to 5V; the mixer is enabled (on).
 4. Set Signal Generator #1 to provide a 1760MHz, -5dBm, CW signal to the demo board LO input port.
 5. Set the Signal Generators #2 and #3 to provide two -10dBm CW signals to the demo board RF input port— one at 140MHz, and the other at 141MHz.
 6. To measure 3rd order distortion and conversion gain, set the Spectrum Analyzer start and stop frequencies to 1898MHz and 1903MHz, respectively. Sufficient spectrum analyzer input attenuation should be used to avoid saturating the instrument.
 7. The 3rd order intercept point is equal to $(P_1 - P_3) / 2 + P_{in}$, where P_1 is the power level of the two fundamental output tones at 1900MHz and 1901MHz, P_3 is the 3rd order product at 1899MHz and 1902MHz, and P_{in} is the input power (in this case, -10dBm). All units are in dBm.
 8. To measure input 2nd order distortion, set the Spectrum Analyzer start and stop frequencies to 2039MHz and 2041MHz, respectively. Sufficient spectrum analyzer input attenuation should be used to avoid saturating the instrument.
 9. The 2nd order intercept point is equal to $P_1 - P_2 + P_{in}$, where P_1 is the power level of the fundamental output tone at 1900MHz, P_2 is the 2nd order product at 2040MHz, and P_{in} is the input power (in this case, -10dBm). All units are in dBm.

QUICK START GUIDE FOR DEMONSTRATION CIRCUIT 644 HIGH LINEARITY UPCONVERTING MIXER

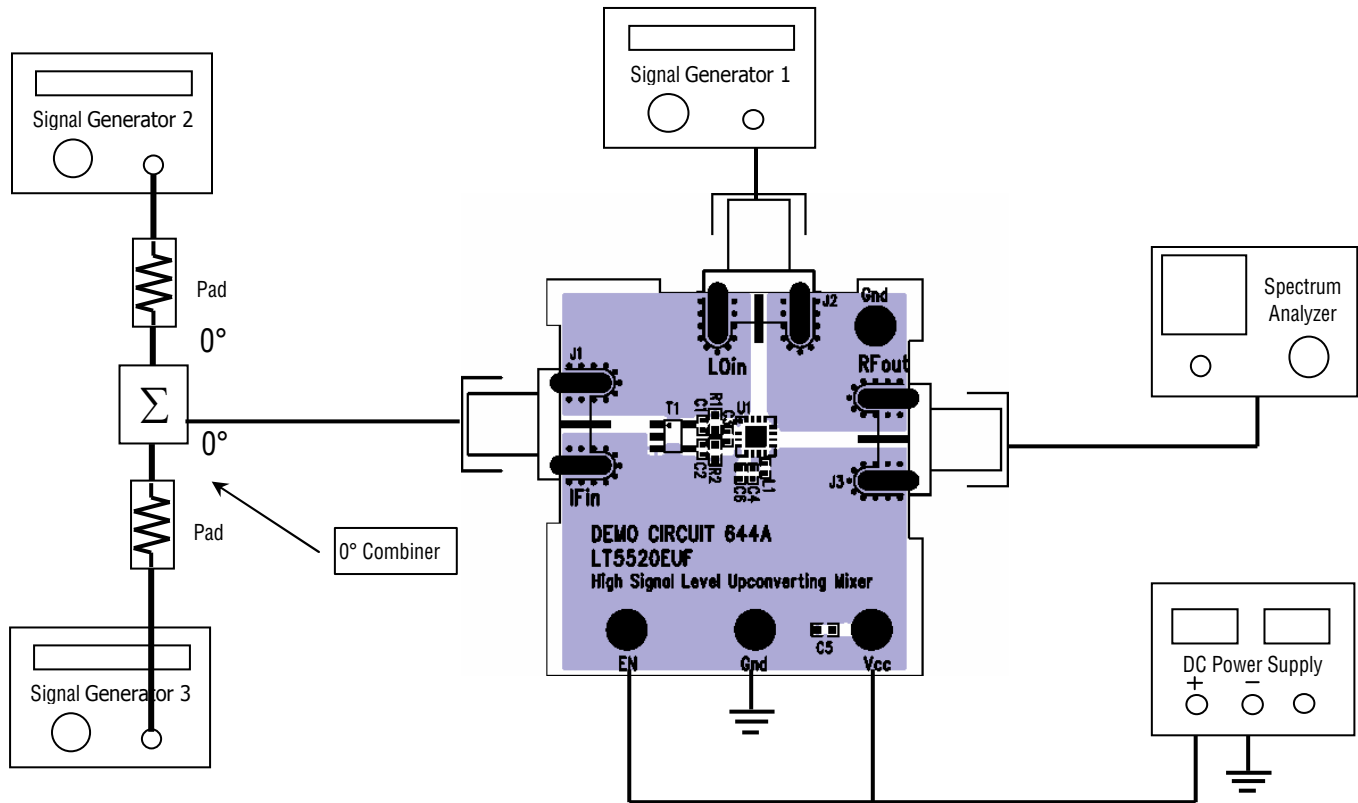
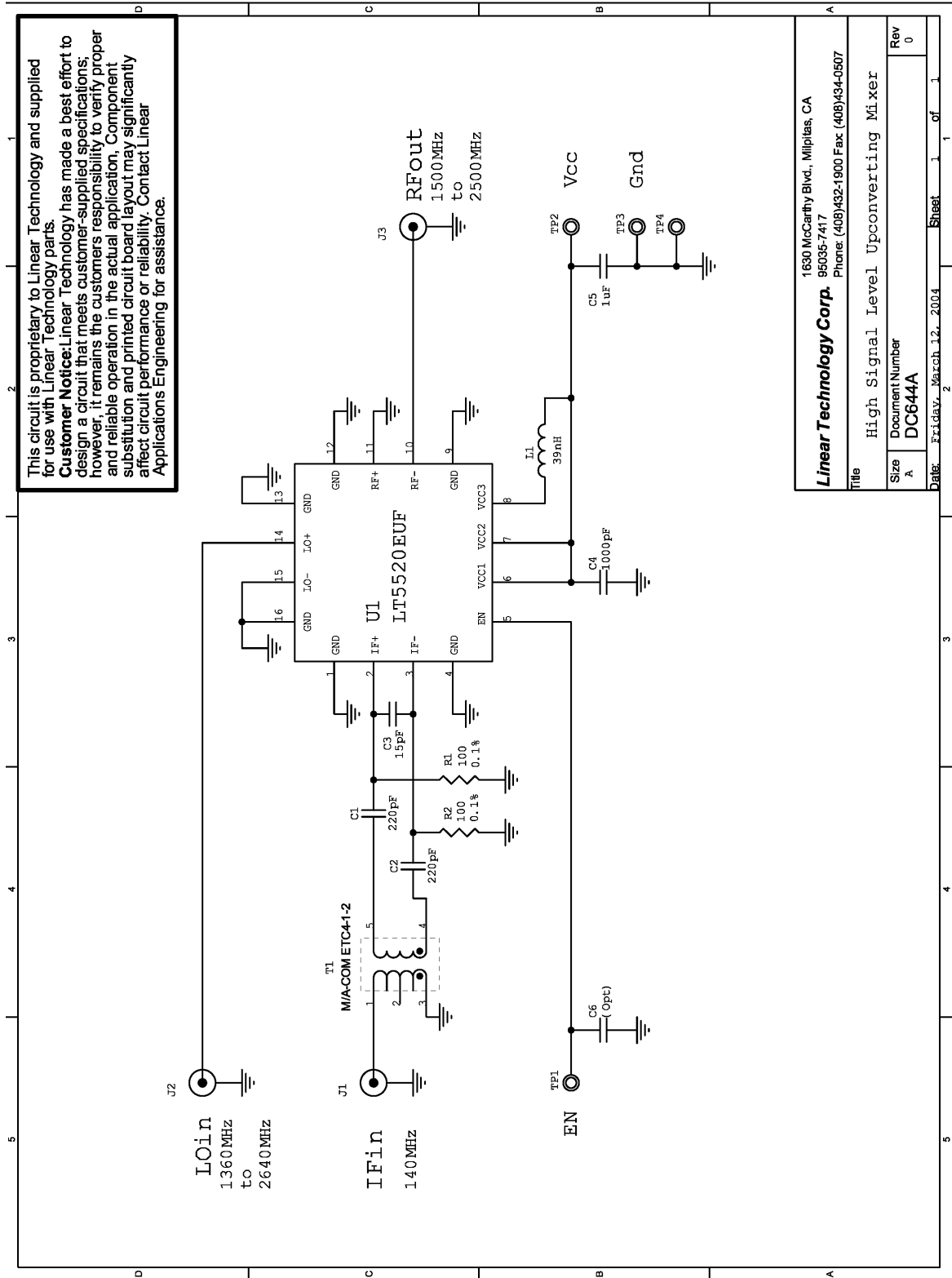

Figure 1. Proper Measurement Equipment Setup

QUICK START GUIDE FOR DEMONSTRATION CIRCUIT 644 HIGH LINEARITY UPCONVERTING MIXER



This circuit is proprietary to Linear Technology and supplied for use with Linear Technology parts.
Customer Notice: Linear Technology has made a best effort to design a circuit that meets customer-supplied specifications; however, it remains the customer's responsibility to verify proper and reliable operation in the actual application. Component substitution and printed circuit board layout may significantly affect circuit performance or reliability. Contact Linear Applications Engineering for assistance.

Linear Technology Corp. 1680 McCarthy Blvd., Milpitas, CA 95035-7417 Phone: (408)432-1900 Fax: (408)434-0507	
Title: High Signal Level Upconverting Mixer	
Size: A	Document Number: DCG44A
Date: Friday, March 12, 2004	Rev: 0
Sheet: 1	of: 1