

## Speaker Amplifier with Speaker Protection

### General Description

The RT5509 is a mono BTL class-D amplifier with cutting-edge speaker protection algorithm. Also, a built-in DC-DC step-up converter is used to provide efficient power for class-D amplifier. I<sup>2</sup>S interface supports two different audio sources while a pair of auxiliary DATAI/O is used for stereo mode or pass-through application. Chip information including gain, speaker protection output or current sense is able to be monitored via DATAO through proper register setting. Speaker protection provides mechanical / thermal protection with accuracy of 10%/±10°C of rated limit.

### Ordering Information

RT5509□  
 □ Package Type  
 WSC : WL-CSP-48B 3.04x2.99 (BSC)

Note :

Richtek products are :

- ▶ RoHS compliant and compatible with the current requirements of IPC/JEDEC J-STD-020.
- ▶ Suitable for use in SnPb or Pb-free soldering processes.

### Marking Information

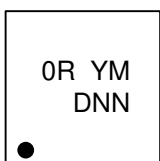

0R : Product Code  
 YMDNN : Date Code

### Features

- **Class-D Speaker AMP**
  - ▶ 4.3W Output Power @ 9.5V, 8Ω Load, THD < 1%
  - ▶ 0/3/6/9/12/15/18dB Boost Gain
  - ▶ 20μV Output Noise @ 0dB Gain
- **Boost Converter**
  - ▶ Adaptive Boost for Speaker, Boost from Battery Supply Up to Programmed Voltage, Max 9.5V
  - ▶ Power Modes : Adaptive Boost, Fixed Boost, Bypass Mode
  - ▶ Switching Frequency 2MHz, Maximum Output Current 1.5A
  - ▶ Support CCM / DCM Compensation, Feedback AD
  - ▶ Digital Part : Voltage Loop in Boost Mode
- **Digital**
  - ▶ Digital Audio Interface Support I<sup>2</sup>S, Left-Justified, Right-Justified
  - ▶ I<sup>2</sup>S Sampling Rate Support Up to 48kHz, 24-bit
  - ▶ Digital Filter, Digital Volume, DRC/Noise Gate
  - ▶ Speaker Protection
  - ▶ Speaker Amplitude Estimation Accuracy : Error < 10%
  - ▶ BI Calibration Function
  - ▶ Temperature Sensing
  - ▶ Speaker Temperature Estimation Accuracy : Error < ±10°C

### Applications

- Smart Phone
- Tablet

### Simplified Application Circuit

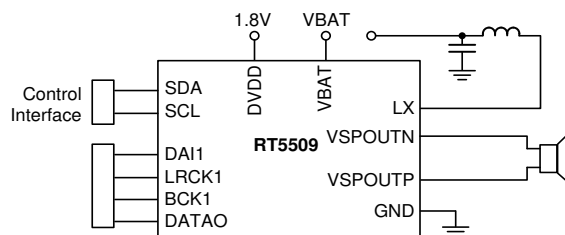

Pin Configuration

(TOP VIEW)

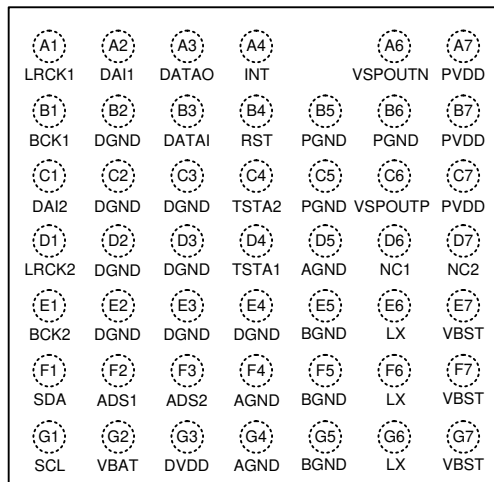

WL-CSP-48B 3.04x2.99 (BSC)

Functional Pin Description

Pin No.	Pin Name	Type	Pin Function
A1	LRCK1	I	I <sup>2</sup> S word select 1.
A2	DAI1	I	I <sup>2</sup> S data input 1.
A3	DATAO	O	I <sup>2</sup> S data output.
A4	INT	O	Interrupt output.
A6	VSPOUTN	O	Class-D inverting output.
A7	PVDD	P	Class-D supply voltage.
B1	BCK1	I	I <sup>2</sup> S Bit clock 1.
B2	DGND	G	Digital / Analog ground.
B3	DATAI	I	I <sup>2</sup> S data input 3.
B4	RST	I	Reset input.
B5	PGND	G	Power ground.
B6	PGND	G	Power ground.
B7	PVDD	P	Class-D supply voltage.
C1	DAI2	I	I <sup>2</sup> S data input 2.
C2	DGND	G	Digital ground.
C3	DGND	G	Digital ground.
C4	TSTA2	O	Test output 2 / short to GND.
C5	PGND	G	Power ground.
C6	VSPOUTP	O	Class-D non-inverting output.
C7	PVDD	P	Class-D supply voltage.
D1	LRCK2	I	I <sup>2</sup> S word select 2.

Pin No.	Pin Name	Type	Pin Function
D2	DGND	G	Digital ground.
D3	DGND	G	Digital ground.
D4	TSTA1	O	Test output 1/ short to GND.
D5	AGND	G	Analog ground.
D6	NC1		No internal connection.
D7	NC2		No internal connection.
E1	BCK2	I	I <sup>2</sup> S bit clock 2.
E2	DGND	G	Digital ground.
E3	DGND	G	Digital ground.
E4	DGND	G	Digital ground.
E5	BGND	G	Boosted ground.
E6	LX	P	Boost converter input.
E7	VBST	O	Boosted supply voltage.
F1	SDA	I/O	I <sup>2</sup> C data.
F2	ADS1	I	Address select 1.
F3	ADS2	I	Address select 2.
F4	AGND	G	Analog ground.
F5	BGND	G	Boosted ground.
F6	LX	P	Boost converter input.
F7	VBST	O	Boosted supply voltage.
G1	SCL	I	I <sup>2</sup> C clock.
G2	VBAT	I	Battery supply sense input.
G3	DVDD	P	Digital / Analog supply voltage.
G4	AGND	G	Analog ground.
G5	BGND	G	Boosted ground.
G6	LX	P	Boost converter input.
G7	VBST	O	Boosted supply voltage.

Functional Block Diagram

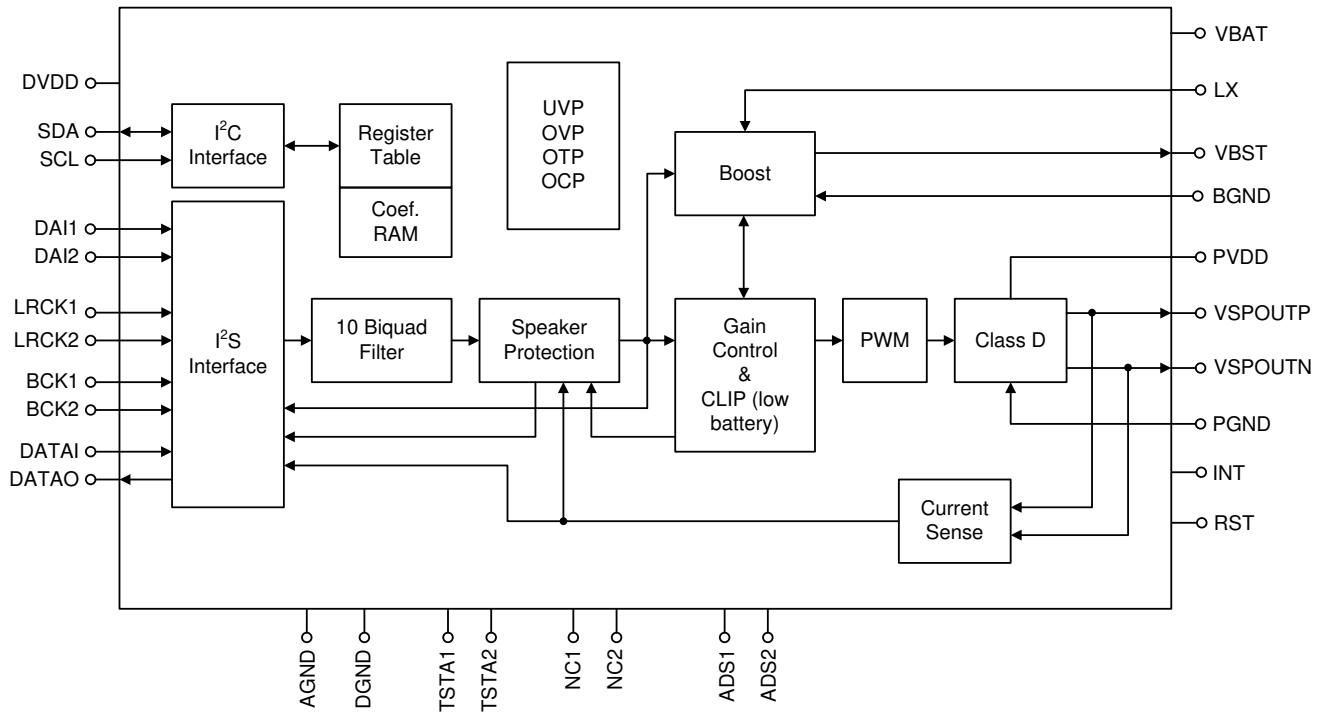

**Absolute Maximum Ratings** (Note 1)

- VBST, PVDD ----- -0.3 to 13V
- VSPOUTP, VSPOUTN, LX ----- -0.3 to 13V
- VSPOUTP, VSPOUTN, LX ----- -1.4 to 16V (Note 6)
- VBAT ----- -0.3 to 6V
- DVDD ----- -0.3 to 2.5V
- LRCK, BCK, DATA I/O, ADS1, ADS2 ----- -0.3 to (DVDD + 0.3V)
- SCL, SDA ----- -0.3 to 6V
- RST ----- -0.3 to (DVDD + 0.3V)
- Power Dissipation, P<sub>D</sub> @ T<sub>A</sub> = 25°C
  - WL-CSP-48B 3.04x2.99 (BSC) ----- 3.7W
- Package Thermal Resistance (Note 2)
  - WL-CSP-48B 3.04x2.99 (BSC), θ<sub>JA</sub> ----- 27°C/W
- Lead Temperature (Soldering, 10 sec.) ----- 260°C
- Junction Temperature ----- 150°C
- Storage Temperature Range ----- -65°C to 150°C
- ESD Susceptibility (Note 3)
  - HBM (Human Body Model) ----- 2kV

**Recommended Operating Conditions** (Note 4)

- Ambient Temperature Range ----- -40°C to 85°C
- Junction Temperature Range ----- -40°C to 125°C

**Electrical Characteristics**

(VBAT = 3.6V, DVDD = 1.8V, T<sub>A</sub> = 25°C, unless otherwise specified)

Parameter	Symbol	Test Conditions	Min	Typ	Max	Unit
<b>Power Supplies</b>						
Digital Supply Voltage	DVDD		1.71	1.8	2	V
Speaker Amp Supply Voltage	PVDD		2.7	3.6	9.5	V
Battery Supply Voltage	VBAT		2.7	3.6	5.5	V
Boost Converter Output Voltage	VBST		2.7	--	9.5	V
Shutdown Current (VBAT)	I <sub>SD_VBAT</sub>	DVDD = 1.8V	0	1	5	μA
Leakage Current (VBAT)	I <sub>LEAKAGE_VBAT</sub>	DVDD = 0V	0	1	5	μA
Leakage Current (DVDD)	I <sub>LEAKAGE_DVDD</sub>	VBAT = 2.7 to 5.5V, DVDD = 1.8V, BCK = LRCK = DAI = 0V	0	8	20	μA
Offset Voltage	V <sub>OS</sub>	PVDD = 3.6V	0	2	6	mV

Parameter	Symbol	Test Conditions	Min	Typ	Max	Unit
<b>DAC to Stereo Speaker Amplifier</b>						
Signal to Noise Ratio	SNR	PVDD = 9.5V, THD+N < 1%, Gain = 12dB, A-Weighting	92	100	108	dB
Noise level	Vn	Gain = 0dB, A-Weighting	15	20	25	μV
		Gain = 12dB, A-Weighting	35	40	45	
		Gain = 18dB, A-Weighting	55	60	65	
Maximum Output Power	Po	1kHz, PVDD = 3.6V, 8Ω load + 22μH, THD + N = 1%	0.6	0.65	0.7	W
		1kHz, PVDD = 9.5V, 8Ω load + 22μH, THD + N = 1%	4.2	4.3	4.4	
THD+N		1kHz, Po = 350mW, 8Ω load + 22μH	-90	-75	-50	dB
PSRR		217Hz ripple = 200mVpp	-85	-75	-65	dB
Quiescent Current (VBAT)	I <sub>Q_VBAT</sub>	Normal operation, DSP, speaker protection bypassed	1	3	5	mA
Quiescent Current (DVDD)	I <sub>Q_DVDD</sub>	Normal operation, DSP, speaker protection bypassed	6	12	18	mA
		Normal operation, DSP, speaker protection activated	12	18	24	
Output Power Efficiency	η	P <sub>O</sub> = 2.5W, including DC to DC converter, 100Hz audio signal	70	76	80	%
<b>I<sup>2</sup>C Interface Electrical Characteristics</b> (Note 5)						
SDA, SCL Input Threshold	V <sub>IH</sub>		0.7 x DVDD	--	--	V
	V <sub>IL</sub>		--	--	0.3 x DVDD	
Pull-Down Current	I <sub>FO2</sub>		--	2	--	μA
Digital Output Low (SDA)	V <sub>OL</sub>	I <sub>PULLUP</sub> = 3mA	--	--	0.4	V
Clock Operating Frequency	f <sub>SCL</sub>		--	--	400	kHz
Bus Free Time Between Stop and Start Condition	t <sub>BUF</sub>		1.3	--	--	μs
Hold Time After (Repeated) Start Condition	t <sub>HD,STA</sub>		0.6	--	--	μs
Repeated Start Condition Setup Time	t <sub>SU,STA</sub>		0.6	--	--	μs
Stop Condition Time	t <sub>SU,STD</sub>		0.6	--	--	μs
Data Hold Time	t <sub>HD,DAT (OUT)</sub>		225	--	--	ns
Input Data Hold Time	t <sub>HD,DAT (IN)</sub>		0	--	900	ns
Data Setup Time	t <sub>SU,DAT</sub>		100	--	--	ns
Clock Low Period	t <sub>LOW</sub>		1.3	--	--	μs
Clock High Period	t <sub>HIGH</sub>		0.6	--	--	μs

Parameter	Symbol	Test Conditions	Min	Typ	Max	Unit
Clock Data Fall Time	$t_F$		20	--	300	ns
Clock Data Rise Time	$t_R$		20	--	300	ns
Spike Suppression Time	$t_{SP}$		--	--	50	ns
<b>I<sup>2</sup>S Interface Electrical Characteristics</b> (Note 5)						
High-Level Input Voltage	$V_{IH}$		0.7x DVDD	--	--	V
Low-Level Input Voltage	$V_{IL}$		--	--	0.3x DVDD	V
Setup Time, LRCK to SCLK Rising Edge	$t_{su1}$		10	--	--	ns
Hold Time, LRCK from SCLK Rising Edge	$t_{h1}$		10	--	--	ns
Setup Time, SDIN to SCLK Rising Edge	$t_{su2}$		10	--	--	ns
Hold Time, SDIN from SCLK Rising Edge	$t_{h2}$		10	--	--	ns
Rise/Fall Time for SCLK/LRCLK	$t_r$		--	--	8	ns

**Note 1.** Continuously stresses beyond those listed “Absolute Maximum Ratings” may cause permanent damage to the device. These are stress ratings only, and functional operation of the device at these or any other conditions beyond those indicated in the operational sections of the specifications is not implied. Exposure to absolute maximum rating conditions may affect device reliability.

**Note 2.**  $\theta_{JA}$  is measured under natural convection (still air) at  $T_A = 25^\circ\text{C}$  with the component mounted on a high effective-thermal-conductivity four-layer test board on a JEDEC 51-7 thermal measurement standard.

**Note 3.** Devices are ESD sensitive. Handling precaution recommended.

**Note 4.** The device is not guaranteed to function outside its operating conditions.

**Note 5.** Guaranteed by design.

**Note 6.** The switching terminal should be used within AC peak limits. Overshoot and undershoot must be less than 100ns.

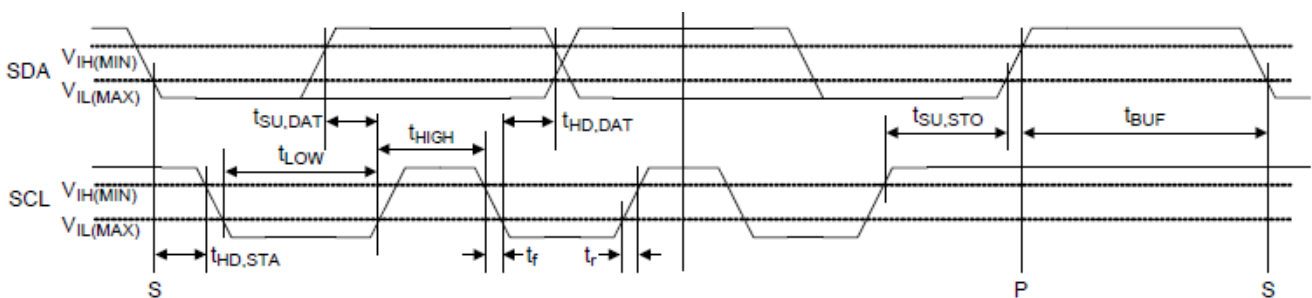

Figure 1. I<sup>2</sup>C Interface Trimming Diagram

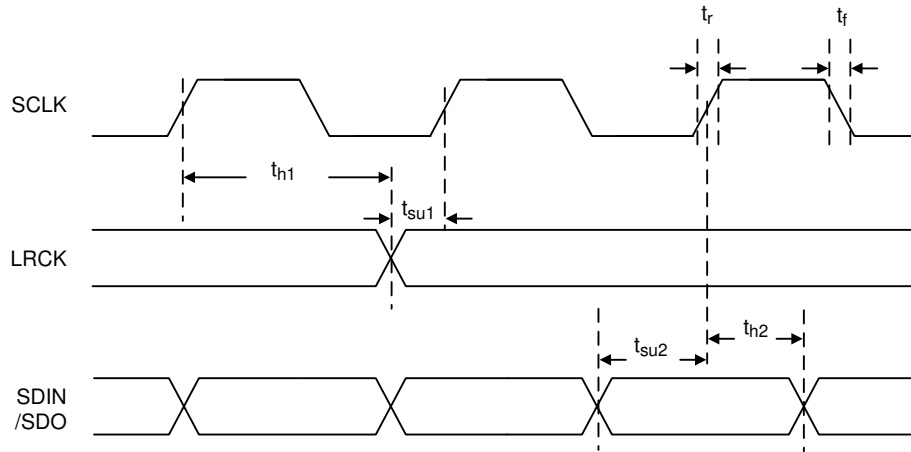

Figure 2. Timing Diagram of Slave Mode I<sup>2</sup>S Interface



**Typical Application Circuit**

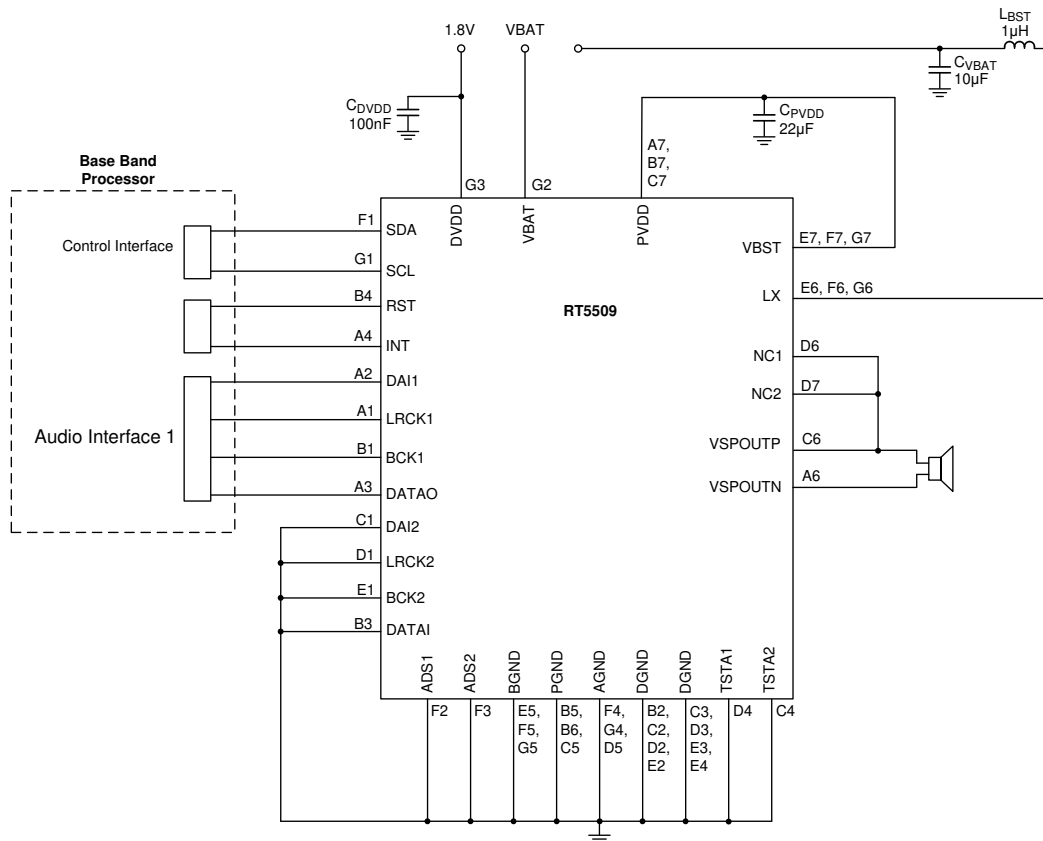

Figure 3. Mono Mode Application Circuit

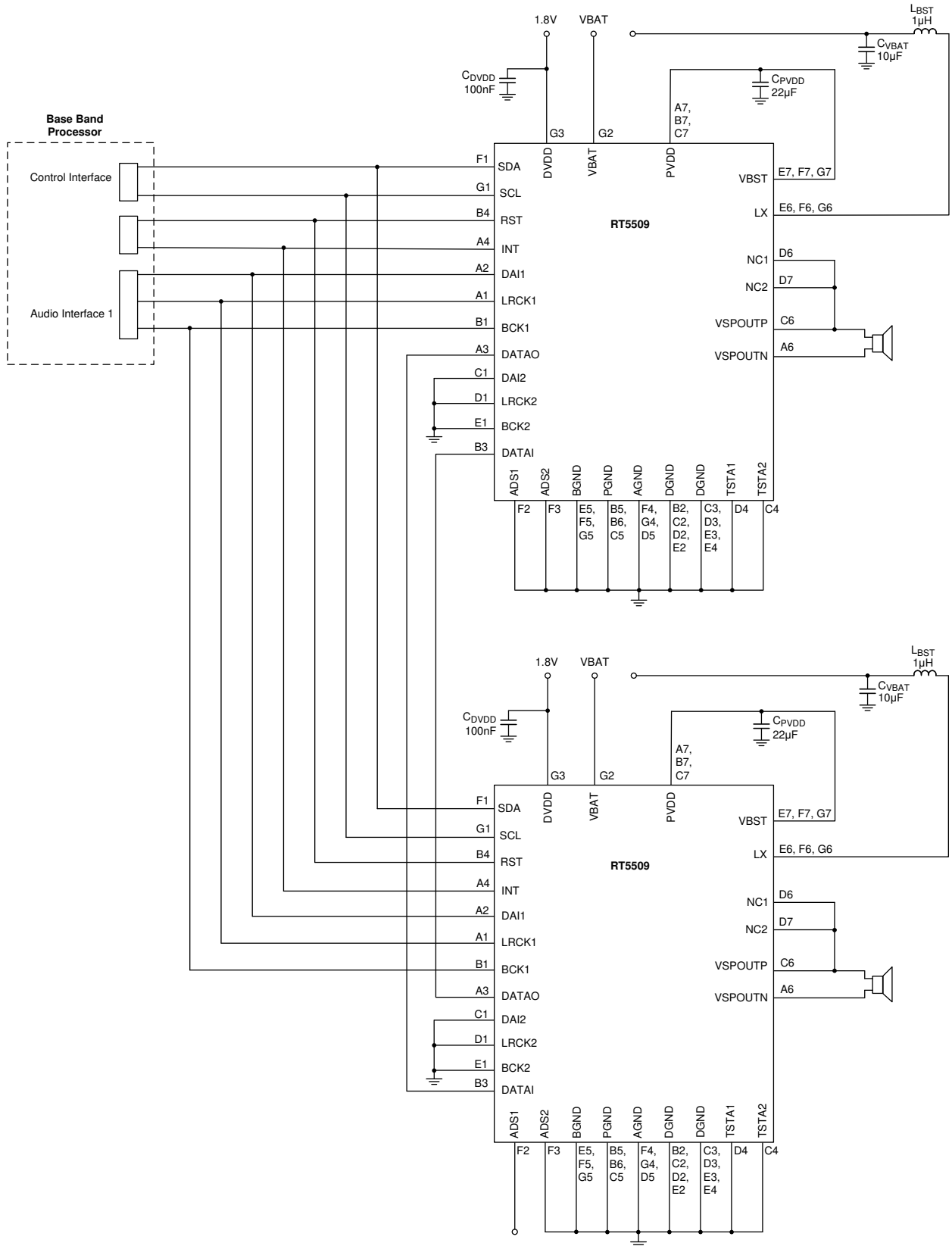
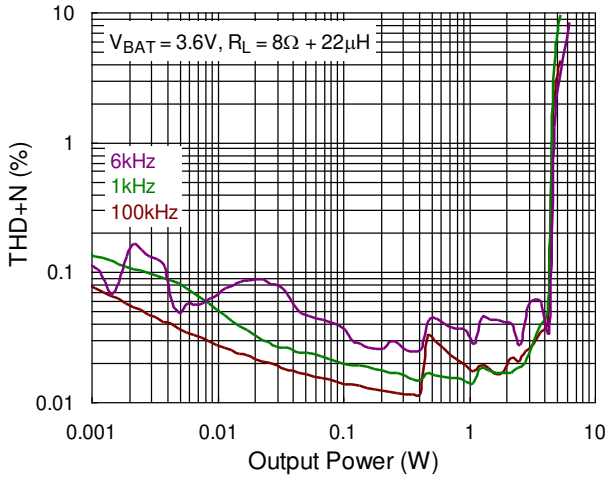

Figure 4. Stereo Mode Application Circuit

**Typical Operating Characteristics**

**THD+N vs. Output Power**



**THD+N vs. Frequency**

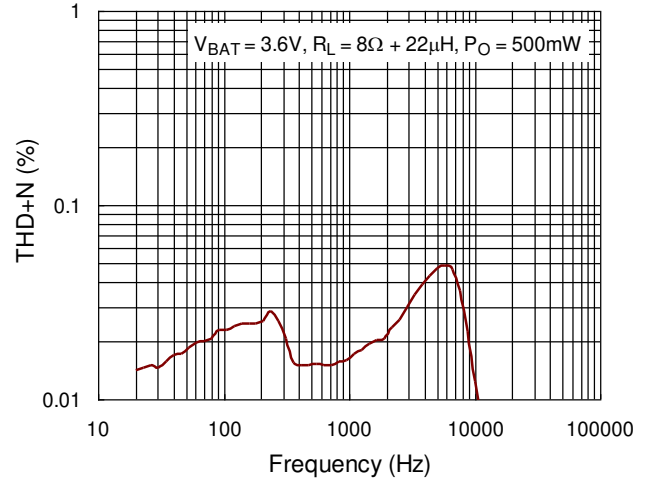

**Efficiency vs. Output Power**

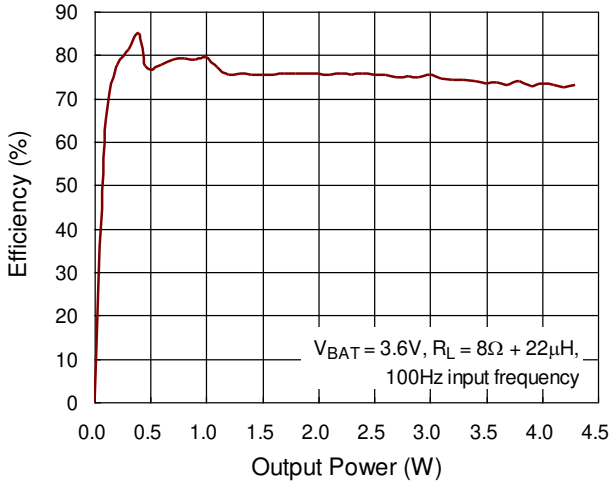

**Output Power vs. Battery Supply Voltage**

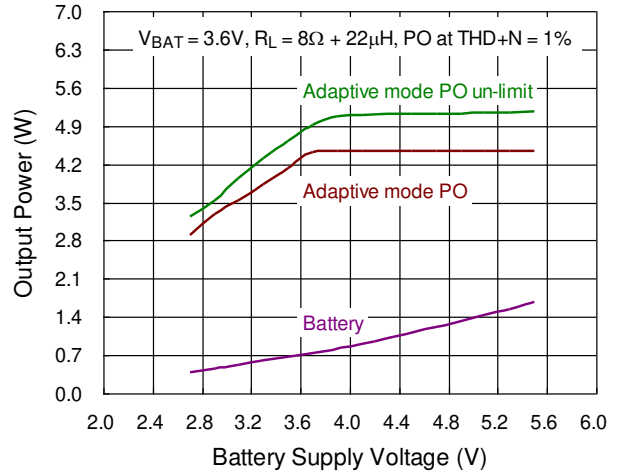

**PSRR**

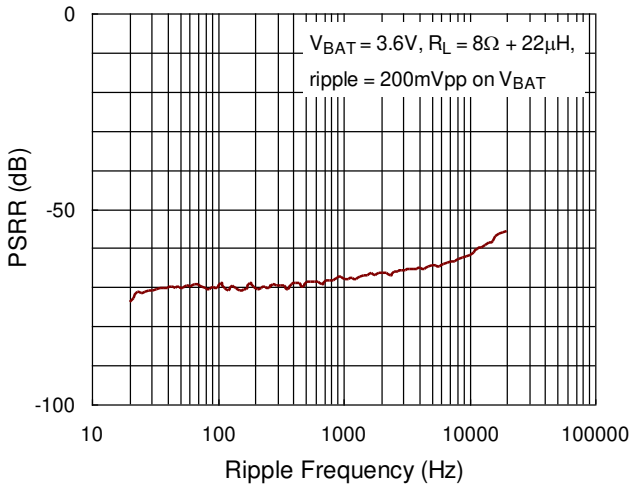

**Boost Change Mode Behavior**

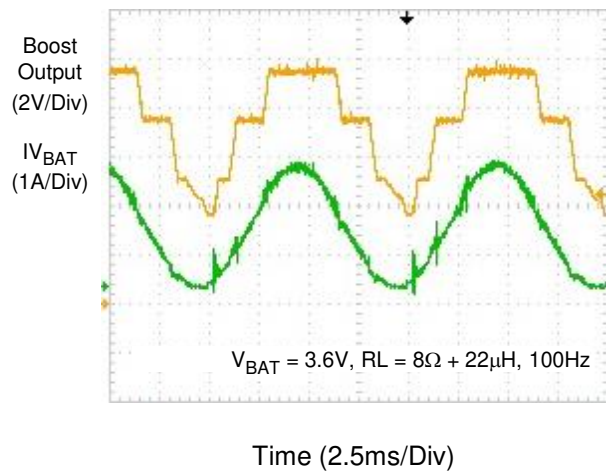

## I<sup>2</sup>C Interface

### Device Addressing

The RT5509 support I<sup>2</sup>C control interface. The default device address is accessed via Pin ADS1 and ADS2. (see Table 1.) Four separate address are supported for stereo mode application. The levels on pins ADS1 and

ADS2 determine the values of bits 1 and 2, respectively. The generic address is independent of pins ADS1 and ADS2.

**Table 1. Address Selection Via Pins ADS1 and ADS2**

ADS2 Pin (V)	ADS1 Pin (V)	Address	Function (bit 0)
0	0	0110100x	0 : write 1 : read
0	DVDD	0110101x	0 : write 1 : read
DVDD	0	0110110x	0 : write 1 : read
DVDD	DVDD	0110111x	0 : write 1 : read

### Read Function

Reading One Indexed Byte of Data from RT (With 1-Byte)

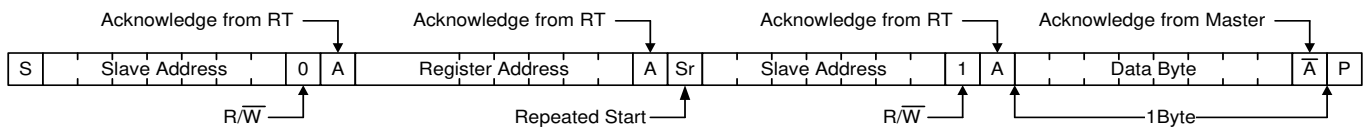

Reading n Indexed Words of Data from RT (With N-Byte)

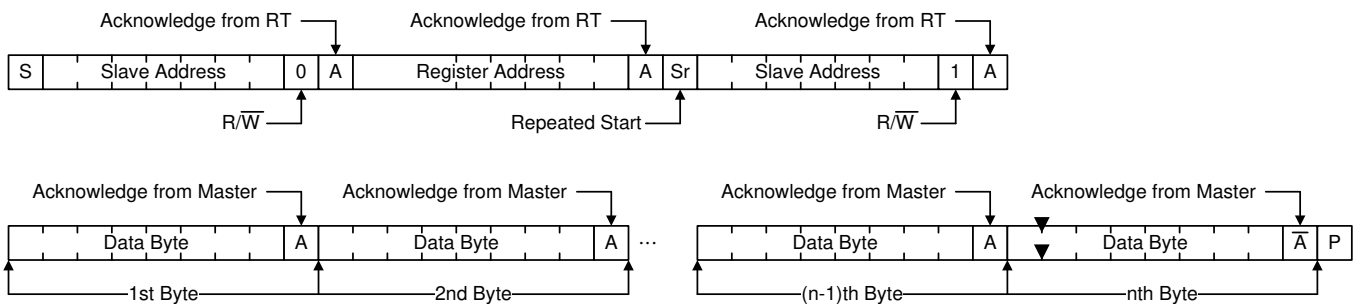

### Write Function

Writing One Byte of Data to RT (With 1-Byte)

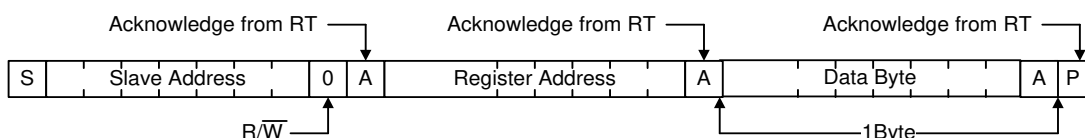

Writing n Byte of Data to RT (With N-Byte)

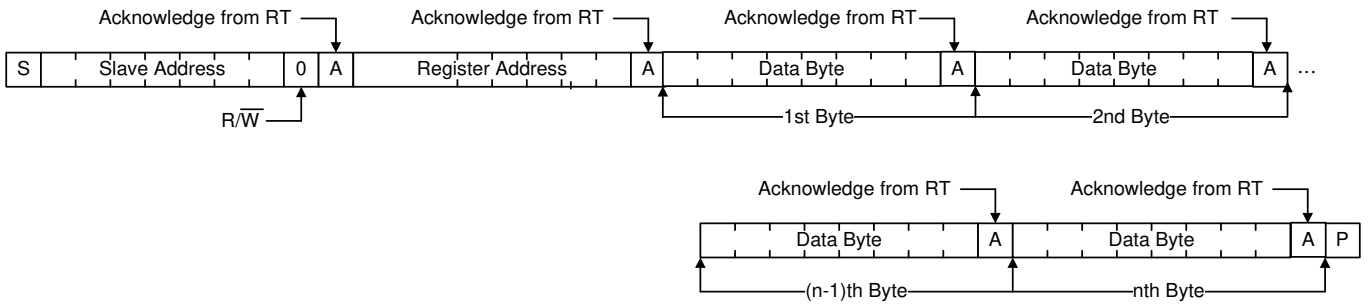

## Operation Mode

The RT5509 can operate in six different modes which are power-down / suspend / operating / mute / off / fault.

Internal functional block operational status in different mode is depicted in Figure 5.

Mode Bik	PWDN	SUSP	OP	MUTE	OFF	FAULT
PLL	×	○	○	○	○	○
I <sup>2</sup> C	○	○	○	○	○	○
I <sup>2</sup> S	×	×	○	○	○	○
SPK	×	×	○	○	○	○
AMP	×	×	○	△	⊠	⊠

- : Normal operation
- △ : Operational with zero input
- ⊠ : Output floating
- ×

Figure 5. Operation Mode

### Power-Down Mode (PWDN = 1)

When PWDN is set to 1, chip will enter power-down mode.

In power-down mode, power consumption is minimum and PWM outputs are floating.

I<sup>2</sup>C remains awake in power-down mode.

If PWDN is set to 1, I<sup>2</sup>S is also disabled.

### Suspend Mode (BCK/LRCK Invalid)

When BCK/LRCK is invalid, chip will enter suspend mode.

In suspend mode, most of the data path are off, and PWM outputs are floating.

I<sup>2</sup>C remains awake in power-down mode.

PLL keeps awake used to monitor BCK/LRCK on I<sup>2</sup>S bus to see if they are correct.

### Operating Mode (PWDN = 0, SPKE = 1, SPKM = 0, AMPE = 1)

Operating mode is selected via PWDN/SPKE/SPKM/AMPE at register 0xXX. One of I<sup>2</sup>S interface (DATA1/DATA2) is selected as the audio source. In

operating mode, the frequency of LRCK should be the same as I<sup>2</sup>SFS.

### Mute Mode (PWDN = 0, SPKE = 1, SPKM = 1, AMPE = 1)

Soft muting is used to prevent pop noise and is implemented in the speaker protection block when SPKE set to logic 1. Ramp up/down in exponential scale are implemented when switching between muted and unmuted mode.

### Off Mode (PWDN = 0, SPKE = 1, AMPE = 0)

The outputs of class-D are floating and chip is biased in off mode.

Soft mute can be executed if AMPDS at register 0xXX equals to 1 before chip enters off mode.

### Fault Mode

Chip enters fault mode when an error event of physical protection mechanisms occurs (OCP/OVP/UVP/OTP).

The outputs of class-D are floating in Fault mode. The system exits from Fault mode after the protection event released for a checking cycle of about 200ms.

**Mode Transition**

The state machine of mode transition is shown in Figure 6. “Mute” mode is not shown in this figure since it can be considered as the sub-mode of the normal Operating mode, only with zero input signal.

The “Off” mode is usually used only in the power down sequence, and is depicted in the next sub-clause. After power on, the control bit will always be reset to PWDN mode.

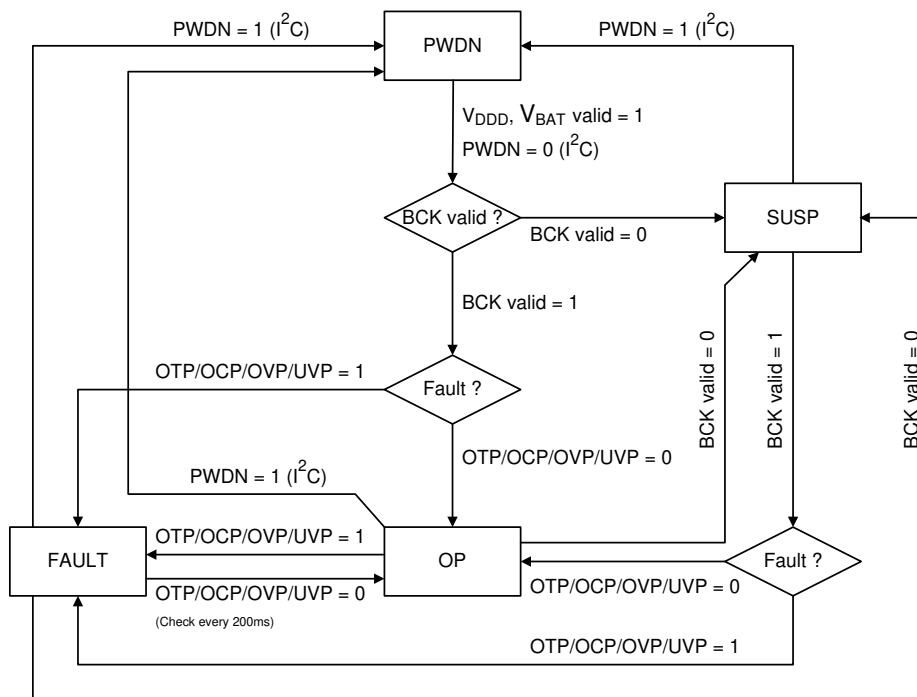

Figure 6. Mode Transition

**Power ON Sequence**

The power on sequence is shown in Figure 7. After power is valid, two groups of control signals should be set, without specific order requirement between these two groups :

1. I<sup>2</sup>C : PWDN, AMPE, SPKE should be programmed. These three bits can be programmed by single command since they are at the same byte address.
  2. I<sup>2</sup>C : I<sup>2</sup>SDIS, I<sup>2</sup>SDF, I<sup>2</sup>SFS set for reference clock selection for PLL.
- I<sup>2</sup>S : BCK should be valid on the specified interface.

If the PWDN is set to 0 before the BCK valid, it will go to SUSP mode automatically. The output of amplifier will be valid after entering OP mode, signal ramp up will always be implemented when the mode transits from PWDN or SUSP mode to OP mode.

**Power OFF Sequence**

The power off sequence is shown in Figure 8. PWDN mode should be set before the power supplies disconnected. To avoid pop or click, the amplifier should be turned off by setting AMPE = 0 before power down. Soft muting will also be enabled automatically if AMPDS bit is set to 1, which further ensures a pop-free procedure.

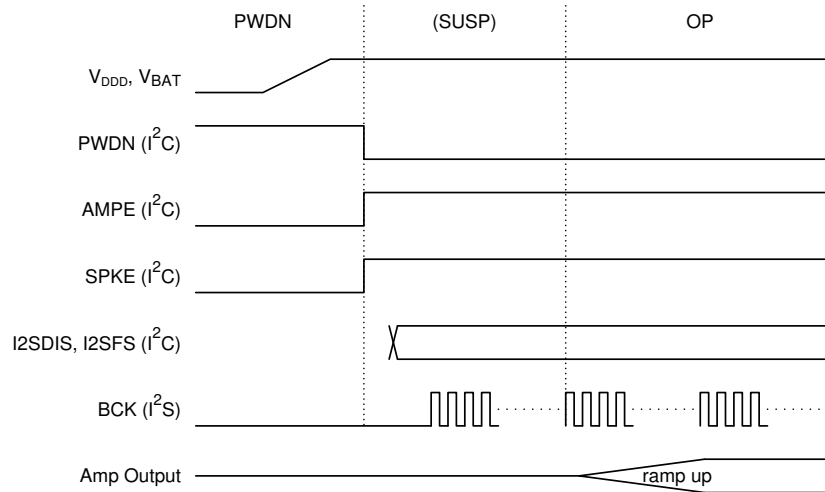

Figure 7. Power ON Sequence

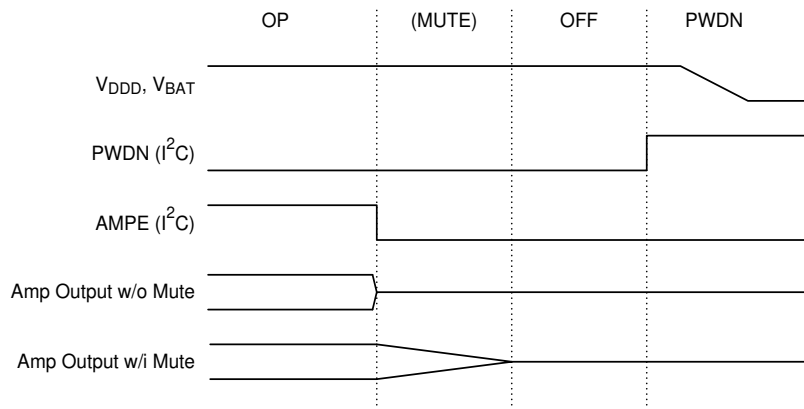

Figure 8. Power OFF Sequence

**I<sup>2</sup>S Mode Change without PWDN**

Suspend mode is detected if the clock source from I<sup>2</sup>S is not valid according to the value of I<sup>2</sup>SDF/I<sup>2</sup>SFS. In this case, soft muting is implemented before entering suspend mode. In the opposite situation, if the clock

source from I<sup>2</sup>S is detected valid again, signal ramp up is implemented at the start after it enters the operating mode.

The above procedure is shown in Figure 9.

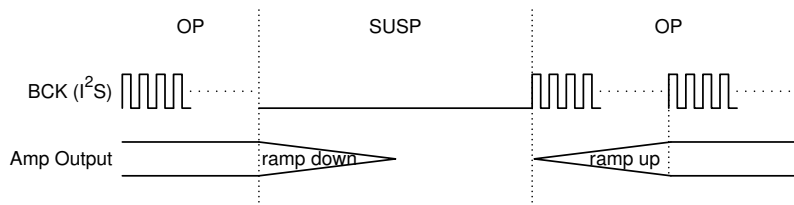

Figure 9. I<sup>2</sup>S Mode Change without PWDN



## Data (I<sup>2</sup>S) Interface

### Data Format

The I<sup>2</sup>S formats supported by the RT5509 are listed below :

Interface	Data Format	BCK Frequency
I <sup>2</sup> S Standard	up to 16-bit	32fs
I <sup>2</sup> S Standard	up to 24-bit	48fs
I <sup>2</sup> S Standard	up to 24-bit	64fs
MSB-justified	up to 16-bit	32fs
MSB-justified	up to 24-bit	48fs
MSB-justified	up to 24-bit	64fs
LSB-justified (16-bit)	16-bit	32fs
LSB-justified (16-bit)	16-bit	48fs
LSB-justified (16-bit)	16-bit	64fs
LSB-justified (18-bit)	18-bit	48fs
LSB-justified (18-bit)	18-bit	64fs
LSB-justified (20-bit)	20-bit	48fs
LSB-justified (20-bit)	20-bit	64fs
LSB-justified (24-bit)	24-bit	48fs
LSB-justified (24-bit)	24-bit	64fs

f<sub>s</sub> : 8kHz, 11.025kHz, 12kHz, 16kHz, 22.05kHz, 24kHz, 32kHz, 44.1kHz, 48kHz

### I<sup>2</sup>S Sampling Rate

I<sup>2</sup>S can support sampling rate of 8kHz, 11.025kHz, 12kHz, 16kHz, 22.05kHz, 24kHz, 32kHz, 44.1kHz, 48kHz, 88.2kHz, 96kHz. As shown in Figure 10, the

sampling rate conversion block is applied to convert the data to internal working sampling rate, that is 44.1kHz or 48kHz. In stereo mode, the gain between two paths can be passed through each other.

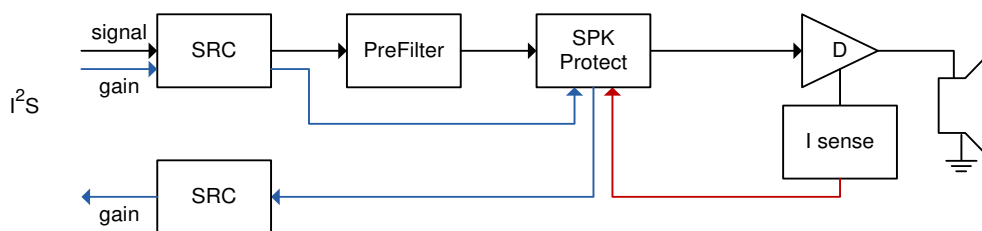

Figure 10. Sampling Rate

### Setting I<sup>2</sup>S Format / Sampling Rate

I<sup>2</sup>S data format and f<sub>s</sub> can be set by I<sup>2</sup>SFOMAT and I<sup>2</sup>SRATE at register 0x04 to 0x05.

The RT5509 should be configured to power down or suspend mode before changing I<sup>2</sup>SFORMAT/I<sup>2</sup>SRATE.

### Input Path

I<sup>2</sup>S input interface is shown in Figure 11. An internal mux select for two audio sources are supported. DATA1 is used to provide stereo or pass-through application and uses BCK1/2, LRCK1/2 as its clock and word select signal. The active I<sup>2</sup>S input is selected by I<sup>2</sup>SDIS

and I<sup>2</sup>SCHS at register 0x06. After selecting I<sup>2</sup>S input source, I<sup>2</sup>SLRS can be used to decide which channel (left, right or mixed) is sent to bi-quads.

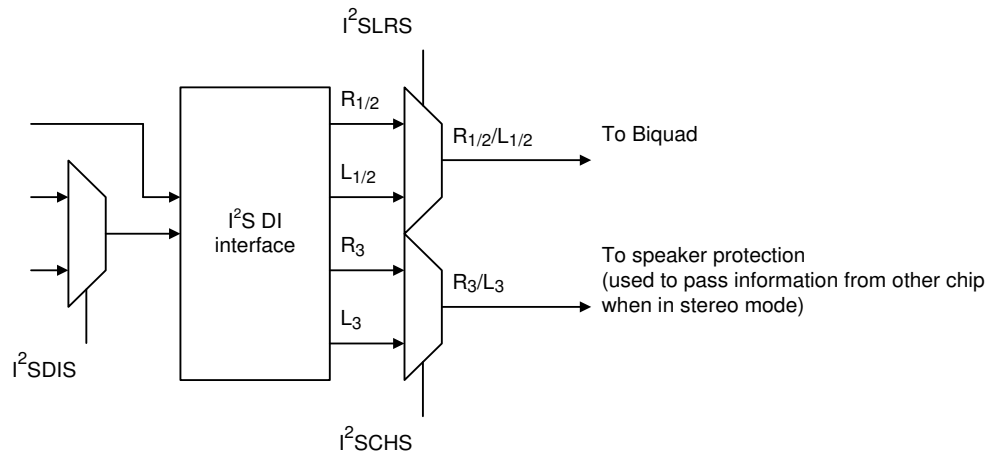

Figure 11. I<sup>2</sup>S Input Mux

**Output Path**

DATAO can output different data via I<sup>2</sup>SDOS/I<sup>2</sup>SDOR /I<sup>2</sup>SDOL at register 0x07 to 0x08. It can also be disabled via I<sup>2</sup>SDOE at register 0x08. DATAO uses

BCK1/2 as its reference clock to transmit desired data. LRCK1/2 is referred when I<sup>2</sup>SDOS/I<sup>2</sup>SDOE is switched to output I<sup>2</sup>SDOR/I<sup>2</sup>SDOL.

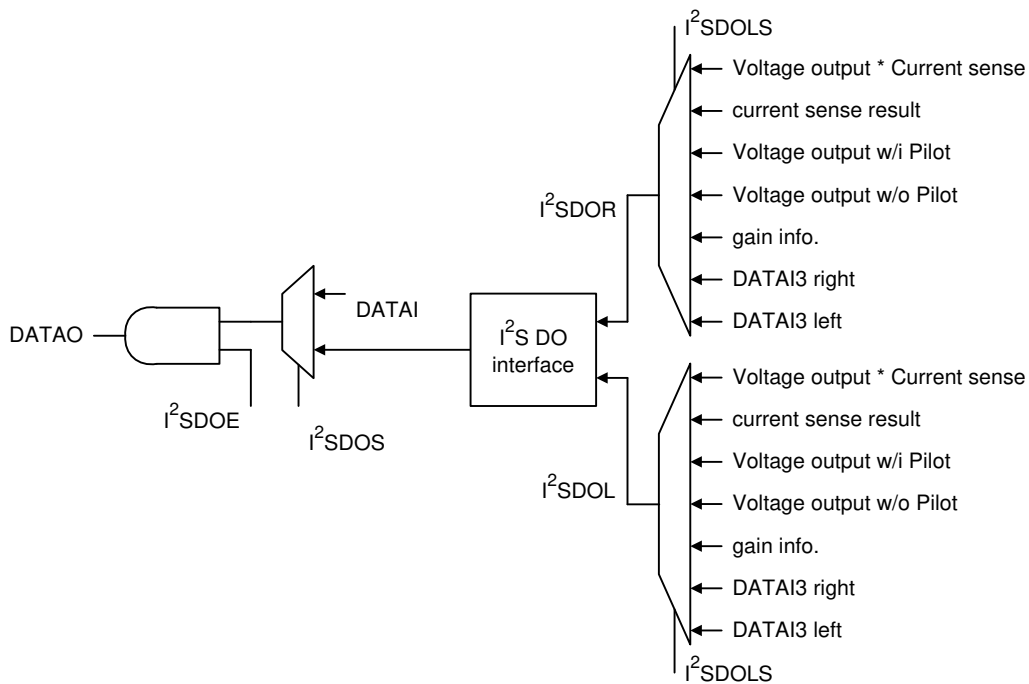

Figure 12. I<sup>2</sup>S Output Mux

**Sampling Rate Delay**

The SRC introduces delay with respect to different I<sup>2</sup>S sampling rates, which is shown in Table 2.

**Table 2. Sampling Rate Conversion Delay**

I <sup>2</sup> S sampling rate	Delay	Absolute Delay
fs = 8k	29/fs	3.6ms
fs = 11.025k	28/fs	2.5ms
fs = 12k	28/fs	2.3ms
fs = 16k	29/fs	1.8ms
fs = 22.05k	26/fs	1.2ms
fs = 24k	26/fs	1.1ms
fs = 32k	29/fs	0.9ms
fs = 44.1k	0/fs	0ms
fs = 48k	0/fs	0ms

The I<sup>2</sup>S signals at different sampling rate are all up-sampled to 48ksps or 44.1ksps before DSP processing or pass-through to PWM + class D amplifier. The data path delay is dominated by the group delay of SRC, the look-ahead delay of gain limiter, and some minor delay in SPK protection algorithm (< 0.5ms).

For example : the worst case loopback delay of I<sup>2</sup>S may be about 16ms (3.6 \* 2 + 8 + 0.5) if fs = 8k and look-ahead delay = 8ms.

**Signal Processing Path**

After sampling rate conversion, the signal is processed by two sub-functions as shown in Figure 13. The pre-filters are some audio effect related functions, and the SPK protection block is the core function for speaker protection.

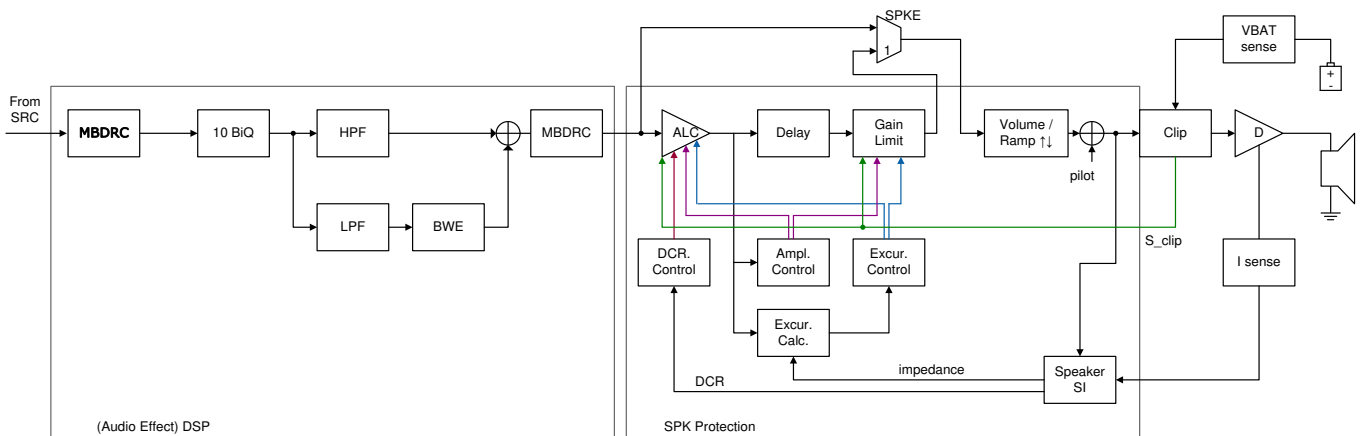

Figure 13. Signal Processing Path

**Pass-Through Mode**

There is pass-through mode for debug or application use.

SPKE = 0 viewed as DSP through mode, where the signal is processed by DSP then passed through volume and amplifier.

Set SPKE = 1 to the normal mode, all functions are turned on regardless of the setting of DSPE.

Pilot is always disabled if SPKE = 0.

**Audio Effect DSP Functions**

**10-BiQuad**

After channel selection, there are 10 fully programmable bi-quad filters implemented for user-specified frequency response. The coefficients are 24-bit 2's complement numbers, which are set by I<sup>2</sup>C interface.

**Band-Split & BWE**

Dedicated HPF/LPF with programmable corner frequency are equipped after 10-Biquad filters, both are implemented by selectable 1<sup>st</sup> or 2<sup>nd</sup> order Butterworth filter.

LPF is only needed when optional BWE is enabled. The BWE block generate harmonic terms to recover the suppressed of low-frequency signal that is not efficiently conveyed on small loudspeaker.

All the HPF/LPF/BWE functions can be bypassed.

**Dynamic Range Control (DRC)**

DRC is a specific feature to automatically adjust the volume gain corresponds to different input signal. With DRC function, the output dynamic range is under controlled from input amplitude is unknown or varies over a wide range. The RT5509 provide three thresholds as dynamic range compression (DRC\_TH0), extension (DRC\_TH1) and Noise Gate. For the application of compression and extension, the slope ratio can be programmed as R0 and R1, respectively.

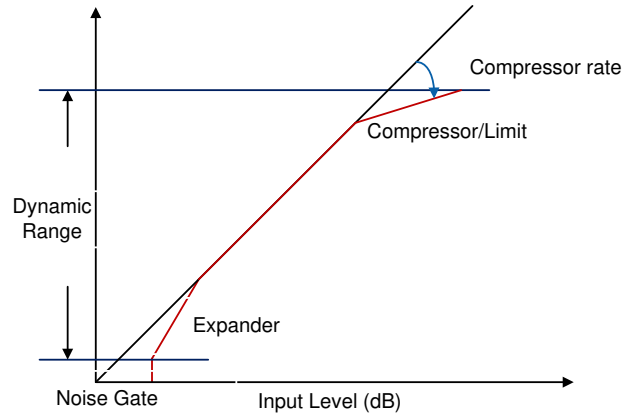

Figure 14. Dynamic Range Control

DRC function is composed of several parts as following Figure. The input signal passes through the programmable Energy Filter (DRC\_AE). The Filter structure is shown in Figure 15. The time constant of each filter can be determined by below equation :

$$t_{window} = \frac{-1}{f_s \ln(1 - ae)}$$

Then, the filtered signal is compared with the given compression threshold. After the comparison between Input signal amplitude and threshold, the Attack Rate (DRC\_AA) determines how quickly the DRC gain decreases when the signal amplitude is high. The Decay Rate (DRC\_AD) determines how quickly the DRC gain increases when the signal amplitude is low.

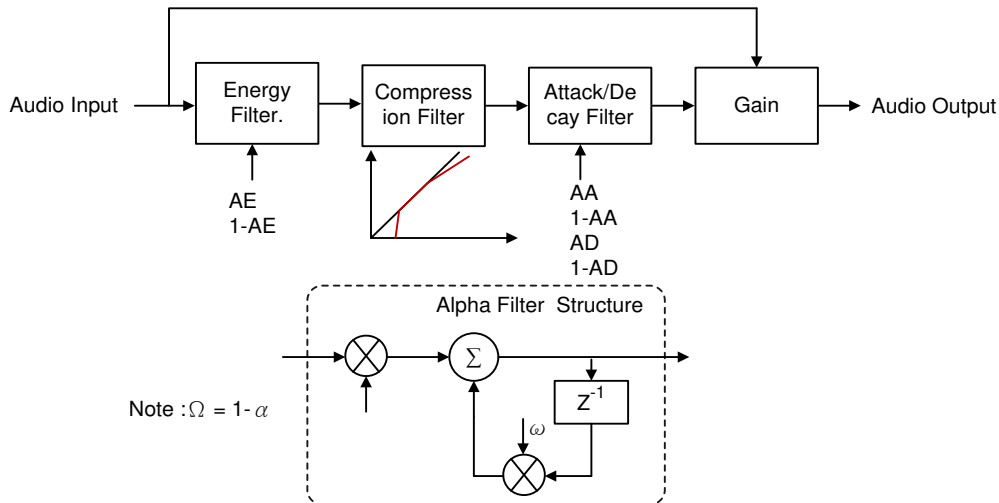

Figure 15. DRC Structure and Signal Processing Path

**Speaker Protection Functions**

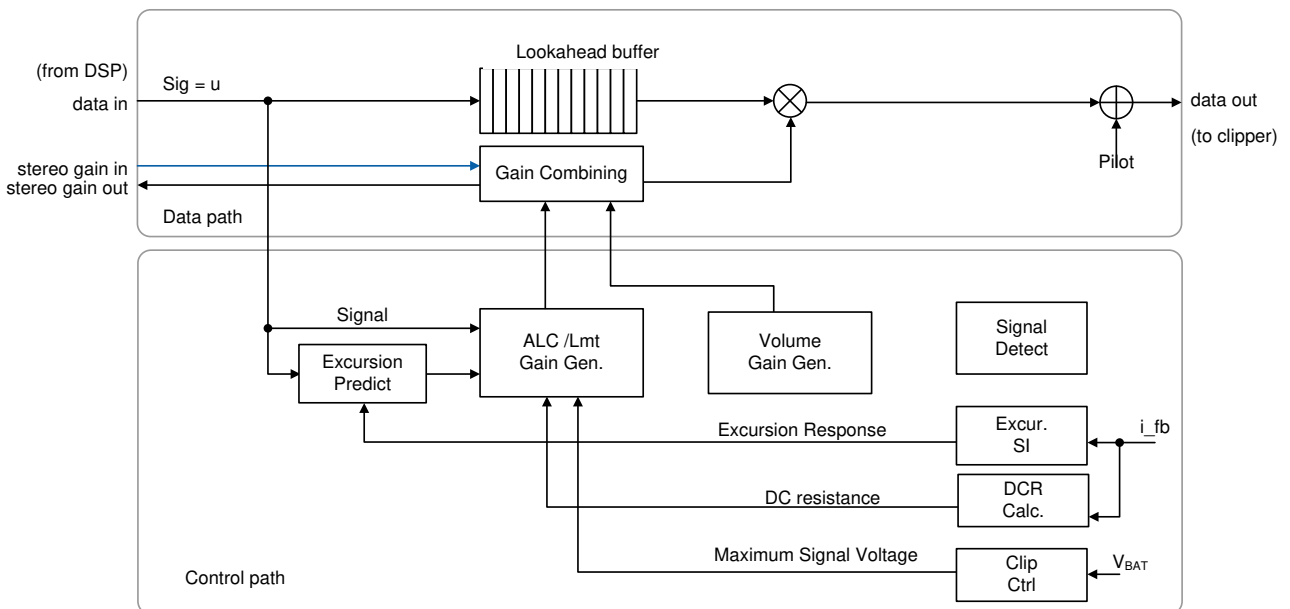

Figure 16. Block Diagram of SPK Protection Function

The following sub-clauses explain the function of each sub-block.

**Look-Ahead Delay Buffer**

Look-ahead delay can be programmed from 0 up to 480 samples, which is up to 10ms at 48k sampling rate. This delay should contain stereo gain synchronization delay.

**Gain Processing on the Data Path**

The level control, limiting for protection, and the volume control are implemented by multiplying the signal on the data path, with the gain generated from the control path.

**Pilot**

The pilot signal, with constant magnitude (30mV) is added at the last stage of data path. The frequency of pilot is fixed  $f_p = 50\text{Hz}$ . The pilot is disabled at

PWDN/SUSPD/Off/Fault/Mute mode. A register control bit can be configured to set if the pilot is also turned off in Silence mode. If yes, then the pilot should be turned off after signal power below threshold for SilenceResetTime. This bit also defines if the DC resistance is monitored or not in Silence mode.

Except for Fault mode, the pilot always turned on or turned off at zero cross level. In worst case the pilot turn-off latency will be 11.6ms.

### Signal Detector

The signal activity is detected when the input signal level is above a user defined threshold. The detection window can be specified to be 5ms/10ms/20ms.

Another long time constant: SilenceRestTime is used to ensure the silence happen and set the ALC to its initial gain.

### Parameters :

sThresAct : silence or active threshold (0 to -90dBFS, -6dB step)

SilenceResetTime : the time to reset ALC gain to initial value (0 to 15 seconds)

### Peak Detector

The peak detector monitors the peak of the signal magnitude and the estimated excursion. The algorithm is described as following equation, with attack time can be specified as 0ms/1ms/2ms/4ms and release time can be specified by (1-RT) represented in 16-bit 2's complement format.

$$xPeak(n) = (1-AT) \times xPeak(n-1) + AT \times |x(n)| \quad \text{for}$$

$$xPeak(n) = (1-RT) \times xPeak(n-1)$$

$$|x(n)| > xPeak(n-1)$$

$$|x(n)| \leq xPeak(n-1)$$

### Automatic Level Control (ALC)

The core of ALC gain control is depicted in Figure 15. The gain is checked and adjusted every ALC\_period, which is specified by UpDoubleTime and DnHalfTime registers. These two register bit fields have physical meaning which mapped to approximately ±6dB per second. They can be specified from 1/16 to 15.9375 seconds with resolution of 1/16s.

The internal logic implements ALC\_period by a counter expired every 16 \* UpDoubleTime or 16 \* DnHalfTime when the gain is going up/dn respectively. Depend on the clock base of I<sup>2</sup>S, the nominal of ±6dB per second for double/half the gain is actually approximately by :

$$44.1k : 20 * \log_{10}((4097/4096)^{(48000/16)}) = 6.36dB;$$

$$20 * \log_{10}((4095/4096)^{(48000/16)}) = -6.36dB$$

$$48k : 20 * \log_{10}((4097/4096)^{(44100/16)}) = 5.84dB;$$

$$20 * \log_{10}((4095/4096)^{(44100/16)}) = -5.84dB$$

### The Parameters for ALC Control :

sThresALC[7:0] : Threshold of signal, specified by 0 to 1. 1 corresponds to the maximum allowable signal specified by clipper module.

xThresALC[7:0] : Threshold of excursion, specified by 0 to 1. 1 corresponds to the maximum allowable excursion.

sThresALC and xThresALC are 8-bit unsigned number representing the value 1/128 to 1, 0x80 is normalized to 1.

UpDoubleTime[7:0] : gain double time = UpDoubleTime /16 (seconds)

DnHalfTime[7:0] : gain half time = DnHalfTime /16 (seconds)

InitUpDoubleTime[7:0] : gain double time used for signal just detected from silence mode.

UpDoubleTime, DnHalfTime, InitUpDoubleTime and InitDnHalfTime are unsigned 8-bit number representing the value 1/16 to 15.9375, 0x10 is normalized to 1.

ALCInitGain[2:0] : ALC initial gain when signal is detected from silence mode. 0 to 21dB, 3dB step.

ALCMaxGain[2:0] : ALC maximum allowable gain. 0 to 21dB, 3dB step.

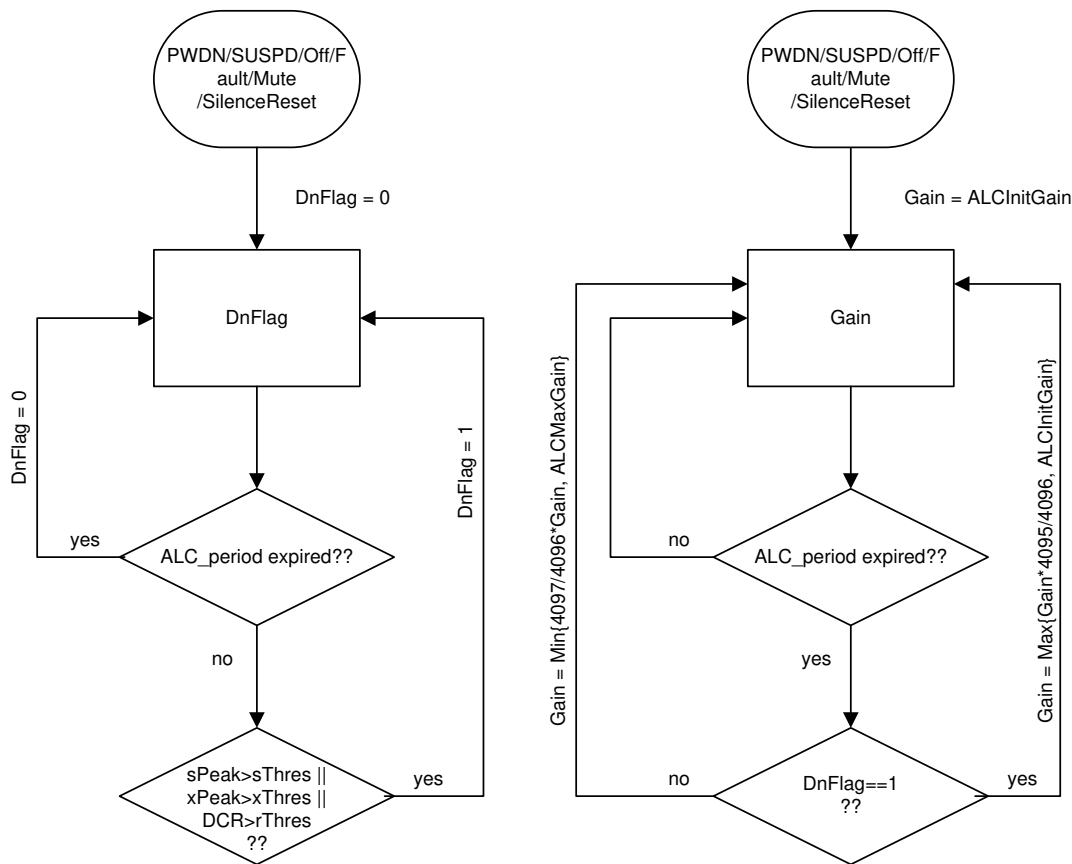

Figure 17. Gain Generation for ALC

**Gain Limiter**

The signal and excursion is limited to ensure the signal is not clipped, and the excursion never growth over the maximum allowable value.

The gain required to limit the signal and excursion are calculated by :

$$G_{Lmt} = \min \left\{ \frac{sThres}{sPeak}, \frac{xThres}{xPeak}, 1 \right\}$$

The parameters for Limiter control :

sThresLmt : Threshold of signal, specified by 0 to 1. 1 corresponds to the maximum allowable signal specified by clipper module.

xThresLmt : Threshold of excursion, specified by 0 to 1. 1 corresponds to the maximum allowable excursion.

xThresLmtDamage : Threshold of excursion when either resistance or excursion damage is detected.

**DC Resistance Control Loop**

**DC Resistance Measurement**

Metal coil resistance is highly linear dependent on the temperature, for example the scale factor is +0.393%/C for copper. The coil resistance is online monitored by the speaker protection algorithm. The update is disabled at PWDN/SUSPD/Off/Fault/Mute mode. A register bit can be set to define if the DC resistance is monitored or not in Silence mode.

The parameters for Coil Resistance :

- ▶ RNML : Nominal resistance of coil ( $\Omega$ )
- ▶ rApp : The application resistance between amplifier and the loudspeaker, normalized to RNML. The application resistance is assumed to be constant through all time.

PI Control Loop :

The parameters for PI-control loop :

- ▶ rMaxExcess : The maximum tolerable resistance growth ratio. 8-bit unsigned number representing the value 1/256 to 255/256
- ▶ PdictWeight : The weighting of prediction
- ▶ Kp : proportional gain of PI-controller
- ▶ KiKpRatio : ratio of Ki/Kp

This value of rMaxExcess should be set correctly considering the material dependent scale factor and the ambient temperature when the resistance calibration procedure is activated.

### Excursion Control Loop

#### Speaker (Impedance) Identification

IIR with 2<sup>nd</sup> to 5<sup>th</sup> order can be chosen in this implementation. 3<sup>rd</sup> order is generally sufficient for the mobile devices, and 5<sup>th</sup> order is reserved for the case when vented-box is implemented. The impedance coefficients update is disabled at PWDN/SUSPD/Off /Fault/Mute mode or when the input signal power is below the threshold of the signal detector (Silence mode).

The parameters for impedance identification

- ▶ SglEn : enable the adaptation in single-tone case
- ▶ SIBlocks : block size to average coefficient update vector
- ▶ SIOrd : order of IIR filter
- ▶ InitImpIDMu : step size to update coefficient in initial stage
- ▶ ImpIDMU : step size in normal stage

#### Excursion Prediction

The excursion is predicted by integrating the back emf, which is induced by the coil movement and direct proportional to its velocity scaled by the BI factor.

#### Resistance Calibration :

A measurement of resistance is activated by register control, after this procedure, the initial value of DCR is saved to One-Time-Program (OTP) memory.

The command/status for DC Resistance Calibration :

- ▶ DCRCalEn : Trigger the automatic DCR calibration procedure once
- ▶ InitDCR : Calibrated DC resistance value

#### BI Calibration

BI factor  $\phi(0)$  can be calibrated to check if the preset coefficient is adequate.

The command/status for BI Calibration :

- ▶ BICalEn : Trigger the automatic BI calibration procedure once
- ▶ InitBIFactor : Calibrated BI factor

#### Speaker Damage Detection

In two cases the loudspeaker is considered as damaged :

1. The DCR deviates for a scale above predefined value.
2. The Resonant deviates for a scale above or below predefined value.

The parameters for Damage detection :

- ▶ rMaxDamage : Threshold of resistor growth, specified by 0 to 1, represents the ratio with respect to the value of initial calibrated resistor. "0" is a special setting that disables this function.
- ▶ fScaleDamage : The boundary for resonant frequency drift vs. the preset resonant frequency. 0 to 1.
- ▶ fRes x fScaleDamage > fRes0 or fRes < fRes0 x fScaleDamage will trigger the damage event.
- ▶ DamgeRecoveryTime : The time (seconds) to recovery from damaged situations. "0" is a special setting that disables this function.

This value of rMaxDamage should be set correctly considering the material dependent scale factor and the ambient temperature when the resistance calibration procedure is activated.



**Volume Control**

The volume control can be set from -127.5dB to 0dB, with step = 0.5dB. The control timing is illustrated as in Figure 18. When a new gain is set by I<sup>2</sup>C, the hardware will change from the original setting in step of 0.5dB/ΔT, where ΔT is the step size with the following options :  
 ΔT = 4, 8, 16, 32, 64 samples, or ΔT = 0 stands for no

ramping up / down is applied.

When mute mode is set by I<sup>2</sup>C or detected by hardware, the volume setting is overruled, but the original gain setting is kept in hardware, allows to be recovered to the original state.

Volume control can be bypassed by register.

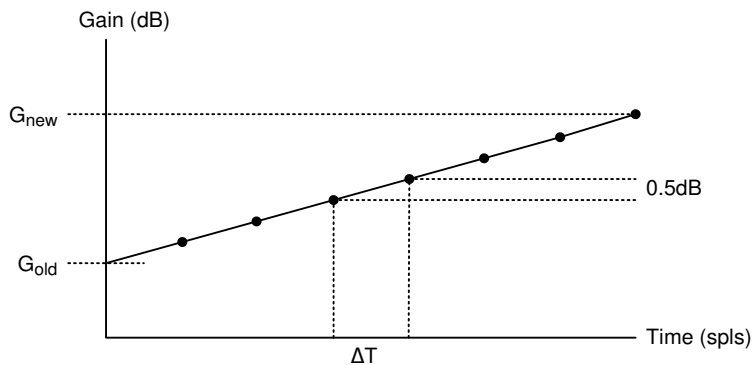

Figure 18. Volume Control Timing Graph

The threshold is normalized to 1 is passed to speaker protection which equals to :

$$\text{ClipThres (normalized)} = \frac{5 - (VBCPS - V_{BAT}) \times CPSLP}{5}$$

ClipThres (normalized) equals to 1 if signal is small and never reaches to the threshold. When signal is large and is clipped by this threshold, ClipThres (normalized) will be sent to speaker protection block.

If battery voltage returns to a hysteresis level, ClipThres will increase by a rate of CLIPRR to a certain level which is defined by VBCPS, CPSLP and VBAT. As ClipThres increases, speaker protection will also increase its gain to let the signal return to its original level. The battery voltage hysteresis can bet set via BVHYS at register 0x0B.

Boost Converter

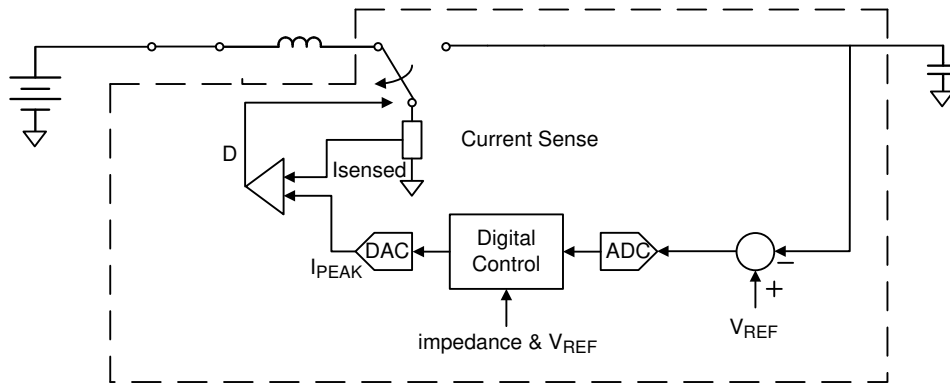

Figure 19. Boost Converter Schematic

A built-in boost converter is used to adjust class-D supply voltage. This converter could be operated in 4 different modes which are :

**Disable Mode**, in this case class-D is powered externally, boost converter is off.

**Battery Mode**,  $V_{BST} = V_{BAT}$ , boost converter is powered, but MOS is switched to OFF state at all times.

**Fixed Mode**,  $V_{BST} = V_{BSTPG}$ ,  $V_{BAT}$  is boosted to a certain value.

**Adaptive Mode**,  $V_{BST}$  depends on the level of signal  
The boost mode can be selected via  $BBMODE$  at register 0x14.

When boost converter is powered and in Boost/Adaptive mode, it tries to regulate the output voltage  $V_{BST}$  to a desired value. The switching frequency  $f_{sw}$  is 2.048MHz (for  $f_s = 8/12/16/24/32$  kHz)/1.8816MHz (for  $f_s = 11.025/22.05/44.1$ kHz).

The digital control logic inside this converter collects  $V_{REF}/load/V_o$  information and then output a  $I_{PEAK}$  value to general a proper  $D$  value which makes  $V_o$  equals  $V_{REF}$ . When in adaptive mode, boost converter can be used to generate required class-D power supply according to  $V_{BAT}$ ,  $TH1/TH2/TH3$ ,  $THT1/THT2/THT3$  and  $TOT$  where  $TH1/2/3$ ,  $THT1/2/3$  and  $TOT$  is at register 0x10 to 0x13. The detail function is shown below :

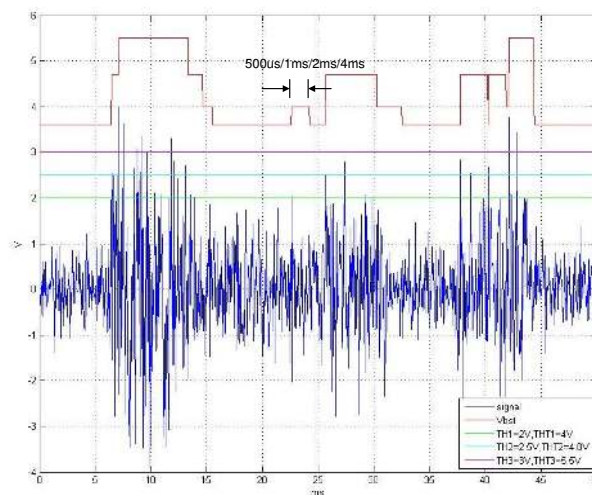

Figure 20. Illustration for Adaptive Boost Mode

TOT can be set to 500us/1ms/2ms/4ms :

```
if ( signal >= THx )
tot_cntx = 1;
elseif ( tot_cntx == TOT )
tot_cntx = 0;
elseif ( tot_cntx ~= 0 )
tot_cntx = tot_cntx+1;
else
tot_cntx = tot_cntx;           (x:1/2/3)
if ( tot_cnt3 > 0 )
vbst = THT3;
elseif ( tot_cnt2 > 0 )
vbst = THT2;
elseif ( tot_cnt1 > 0 )
vbst = THT1;
else
vbst = VBAT;
```

## Register Definition

### Address Mapping

### Registers Description

ADDR	Byte	Bits	R/W	Name	Description	Default
0x00	1	7:0	R	CHIP_ID[7:0]	Chip Revision ID	
0x01	1	7	R	BCK_CLOCK_STABLE	BCK rate stable	1
		6	R	PLL_LOCK	PLL is locked to BCK or LRCK 0 : unlocked 1 : locked	0
		5	R	BAT_UV	Battery voltage under threshold 0 : normal 1 : under threshold	0
		4	R	AMP_OV	Class-D amplifier supply voltage (VDDP) over threshold 0 : normal 1 : over threshold	0
		3	R	AMP_OC	Class-D amplifier output current over threshold 0 : normal 1 : over threshold	0
		2	R	AMP_OT	Class-D amplifier temperature over threshold 0 : normal 1 : over threshold	0
		1	R	BST_OC	Boost converter current over threshold 0 : normal 1 : over threshold	0
		0	R	BST_OT	Boost converter temperature over threshold 0 : normal 1 : over threshold	1
0x02		7:2	R/W	AUD_WL	Audio interface word length. Valid range : 16 bit – 32bit	6'b100100
		1	WC	flagResDmg	resistance exceeds the predefined value	1'b0
		0	WC	flagFreqDmg	resonant frequency out of range	1'b0

ADDR	Byte	Bits	R/W	Name	Description	Default
0x03	1	7:6		Reserved		
		5	R/W	D_EN_TRIWAVE	Enable triangle wave generator	0
		4	R/W	AMPDS	Soft off mode enable 0 : Enter soft mode before off mode 1 : enter off mode directly	0
		3	R/W	AMPE	Class D Enable 0 : disable Class D 1 : enable Class D	0
		2	R/W	SPKM	Speaker protection mute 0 : disable speaker protection mute 1 : enable speaker protection mute	0
		1	R/W	SPKE	Speaker protection block enable 0 : disable speaker protection 1 : enable speaker protection	0
		0	R/W	PWDN	Chip power down control 0 : chip enable 1 : chip power down	1
0x04	1	7:6		Reserved		
		4	R/W	DSP_MODE_SEL	0 : DSP_MODE_A 1 : DSP_MODE_B	0
		3:2	R/W	AUD_FMT[1:0]	00 : I <sup>2</sup> S 01 : Left Justify 10 : Right Justify	2'b00
		1:0	R/W	AUD_BITS[1:0]	00 : 24 Bits 01 : 20 Bits 10 : 18 Bits 11 : 16 Bits	2'b00
0x05	1	7	R	BCK_VALID	BCK stable and match with BCK_MODE setting	0
		6	R/W	BCK_MODE_DET_EN	Check BCK_VALID to enable audio path 0 : without check BCK_VALID 1 : check BCK_VALID	0
		4:3	R/W	BCK_MODE[1:0]	BCK Mode Select 00 : 32fs 01 : 48fs Others : 64fs	2'b10
		2:0	R/W	SR_MODE[1:0]	Sampling Rate Select 000 : 8K 001 : 12K/11.025K 010 : 16K 011 : 24K/22.05K 100 : 32K 101 : 48K/44.1K 110 : 96K/88.2K 111 : 192K/176.4K	3'b101

ADDR	Byte	Bits	R/W	Name	Description	Default
0x06	1	7:4		Reserved		
		3:2	R/W	I <sup>2</sup> SLRS	Biquad input selection 00 : left channel 01 : (left+right) / 2 10 : right channel 11 : reversed	2'b01
		1	R/W	I <sup>2</sup> SCHS	I <sup>2</sup> S interface DATAI3 channel selection 0 : from DATAI3 left channel 1 : from DATAI3 right channel	0
		0	R/W	I <sup>2</sup> SDIS	I <sup>2</sup> S interface 1/2 selection 0 : from I <sup>2</sup> S interface 1 1 : from I <sup>2</sup> S interface 2	0
0x07	1	7:4	R/W	I <sup>2</sup> SDORS	DATAO right channel output selection(DATA.R format: Q0.23) 0x0 : DATAI3 left = DATAO.R 0x1 : DATAI3 right = DATAO.R 0x2 : gain information = DATAO.R 0x3 : voltage output w/o pilot = DATAO.R*16 0x4 : voltage output w/l pilot = DATAO.R 0x5 : current sense result = DATAO.R 0x6 : (voltage output w/l pilot) * current sense = DATAO.R * 16 0x7 : FDRC_DATA_OUT = DATAO.R 0x8 : SPK_DATA_OUT = DATAO>R 0x9 : est. current (for excursion est.) = DATAO.R 0xa : estimated current error = DATAO.R 0xb : rx_pilot = DATAO.R 0xc : estimated excursion = DATAO.R * 16 0xd : estimated Resistor = DATAO.R * 16 0xe : input signal behind notch filters = DATAO.R 0xf : excursion peak = DATAO.R	4'h5

ADDR	Byte	Bits	R/W	Name	Description	Default
0x07	1	3:0	R/W	I <sup>2</sup> SDOLS	DATAO left channel output selection(DATA.L format: Q0.23) 0x0 : DATAI3 left = DATAO.L 0x1 : DATAI3 right = DATAO.L 0x2 : gain information = DATAO.L 0x3 : voltage output w/o pilot = DATAO.L*16 0x4 : voltage output w/l pilot = DATAO.L 0x5 : current sense result = DATAO.L 0x6 : (voltage output w/l pilot) * current sense = DATAO.L * 16 0x7 : EQ_DATA_OUT = DATAO.L 0x8 : DAC_DATA_IN = DATAO.L 0x9 : voltage input for excursion estimation = DATAO.L 0xa : est. current (for sys. identification) = DATAO.L 0xb : estimated velocity = DATAO.L * 16 0xc : digital maximum allowable absolute data = DATAO.L 0xd : side channel gain = DATAO.L 0xe : voltage from spkfb = DATAO.L 0xf : speaker protection input data = DATAO.L	4'h4
0x08	1	7:3		Reserved		
		2:1	R/W	I <sup>2</sup> SDOS	DATAO pass through selection 11 : DATAO is from DATAI1 10 : DATAO is from DATAI2 01 : DATAO is from DATAI3 00 : DATAO is from I <sup>2</sup> SDOR/L	2'b00
		0	R/W	I <sup>2</sup> SDOE	DATAO output enable 0 : disable 1 : enable	0

ADDR	Byte	Bits	R/W	Name	Description	Default
0x09	1	7	R/W	ORDER_DSP	0 : EQ → BWE → DRC 1 : DRC → EQ → BWE	1
		6	R/W	STRSYNC	Gain Synchronize in stereo mode 0 : Don't sync 1 : Sync to use minimum gain from two channels	0
		5	R/W	LMTEN	Limiter Enable 0 : Disable 1 : Enable	0
		4	R/W	ALCEN	ALC gain Control enable 0 : disable 1 : enable	0
		3	R/W	MBDRcen	Multi-Band DRC Enable 0 : Disable 1 : Enable	0
		2	R/W	BWEEN	LPF + BWE enable 0 : disable, output zero at lower branch 1 : enable	0
		1	R/W	HPFEN	HPF enable 0 : Bypass at upper branch 1 : enable	0
		0	R/W	BQEN	10 Band BQ Enable 0 : Bypass 10 band BQ 1 : Enable 10 band BQ	0
0x10	1	7:3		Reserved		0
		2:0	R/W	VBCPS	Clip threshold setting 000 : 4.0V 001 : 3.75V 010 : 3.6V 011 : 3.45V 100 : 3.3V 101 : 3.15V 110 : 3V 111 : 2.85V	0



ADDR	Byte	Bits	R/W	Name	Description	Default
0x11	1	7	R/W	CLPE	Clip enable	0
		6	R/W	Reserved		
		5:4	R/W	BVHYS	Battery voltage recovery hysteresis 00 : battery voltage + 0.05 01 : battery voltage + 0.1 10 : battery voltage + 0.15 11 : battery voltage + 0.2	2'b00
		3:2	R/W	CLIPRR	Rate of V <sub>O</sub> threshold recover when VBAT return 00 : increase by 1/8 of original V <sub>O</sub> per 1s 01 : increase by 1/8 of original V <sub>O</sub> per 1.5s 10 : increase by 1/8 of original V <sub>O</sub> per 2s 11 : increase by 1/8 of original V <sub>O</sub> per 2.5s	2'b00
0x12	2	15:10	R/W	Reserved		
		9:0	R/W	CPSLP	Clip slope setting : For example 3V <sub>O</sub> / VBAT CPSLP = 3 / DtoA GAIN (DAC + CLASS-D)	10'h000
		15:0	R/W	VOMIN	Minimum Clip threshold converted from (V) For example, minimum clip threshold is 2.5V, then V <sub>O_MIN</sub> = 2.5V / DtoA GAIN (DAC + CLASS-D) 16'b0 : no minimum	16'h0000
		15:0	R/W	SIGMAX	Digital maximum allowable absolute data: SIG_MAX = max absolute voltage (V) / DtoA GAIN (DAC+CLASS-D) This value should be less than 1	16'h4000
0x15	1	7	R/W	D_ADC_BUF_EN	IMADC VREF BUF enable	0
		6	R/W	D_BYPASS_OCP_EN	Boost bypass mode OCP enable	0
		5	R/W	D_PREDRV_EN	Boost predriver enable	0
		4	R/W	D_ISENSE_EN	Boost current sense enable	0
		3	R/W	D_CMPPWM_EN	Boost comparator enable	0

ADDR	Byte	Bits	R/W	Name	Description	Default
0x1B	1	7:0	R/W	VBAT_GAIN	Mapping VBAT 1LSB to real value (1LSB = 1/1024V) : Ex. VBAT 1LSB = 5mV VBAT_GAIN = 0.005/(1/1024) * 32 =	(MTP)
0x1E	1	1:0	R/W	BST_MODE	Boost mode : 00 : disable 01 : battery 10 : fixed 11 : adaptive	2'b00
0x1F	1	11:6	R/W	BST_THT1	000000 : disabled 000001 to 100001 : 2.9 + BST_THT1 * 0.2V e.g. 000001 : 3.1V, 100001 = 9.5V 100010 to 111111 : Reserved	6'b000000
		5:0	R/W	BST_TH1	000000 : disabled 000001 to 100001 : 1.3 + BST_THT1 * 0.2V e.g. 000001 : 1.5V, 100001 = 7.9V 100010 to 111111 : Reserved	6'b000000
0x20	1	11:6	R/W	BST_THT2	same defination as BST_THT1	6'b000000
		5:0	R/W	BST_TH2	same defination as BST_TH1	6'b000000
0x21	1	11:6	R/W	BST_THT3	same defination as BST_THT1	6'b000000
		5:0	R/W	BST_TH3	same defination as BST_TH1	6'b000000
0x22	1	7	R/W	EN_AMP_OCP_LATCH	1: enable amplifier OCP latch	0
		3:2	R/W	SLEW_RATE	VBST slew rate when using adaptive mode : 00 : 2.5mV/μs 01 : 5mV/μs 10 : 10mV/μs 11 : 20mV/μs	2'b01
		1:0	R/W	BST_TOT	Level timeout time : 00 : 500μs 01 : 1ms 10 : 2ms 11 : 4ms	2'b01
0x23	1	7:0	R/W	SIG_GAIN	Signal path gain : SIG_GAIN = DA gain * other analog gain * 10	8'h69
0x24	1	5	R/W	DCM_EN	DCM enable : 0 : disable 1 : enable	1
		4	R/W	PSM_EN	PSM enable : 0 : disable 1 : enable	1

ADDR	Byte	Bits	R/W	Name	Description	Default
0x25	1	7:6	R/W	Reserved		
		5:0	R/W	PSM_THR1	PSM IPEAK value setting : When 6-bit IDAC1 < PSM_THR1, PSM mode is enabled if PSM_EN and DCM_EN is on. The actual IPEAK is calculated as following: IPEAK to (IDAC1(6-bit) * 0.625e-3 *12.2 * 50 /6.1) – (slope_comp * (1-VBAT * effi / VBST))	6'b000000
0x26	1	7:4	R/W			
		3	R	OC_EV	OC event happens	
		2	R	OT_EV	OT event happens	
		1	R/W	OCP_EN	Over-current protection enable : 0 : disable 1 : enable	1
0x2B	1	7	R/W	Reserved		
		6:0	R/W	CC_MAX	IDAC1 peak value	6'b000000
0x2C	1	7	R/W	Reserved		
		6:0	R/W	OCP_CURR	IDAC1 6-bit ocp enable level	6'b0

ADDR	Byte	Bits	R/W	Name	Description	Default
0x2D	2	15:12		Reversed		
		11	RC	INT_LEAK_SPK	Speaker air leak interrupt	0
		10	R	INT_flagResDmg	Similar as 0x02 flagResDmg, but this bit CAN'T be cleared by read, and only can be clear by write 0 to corresponding bit in register 0x02	0
		9	R	INT_flagFreqDmg	Similar as 0x02 flagFreqDmg, but this bit CAN'T be cleared by read, and only can be clear by write 0 to corresponding bit in register 0x02h	0
		8	RC	INT_STB_BCK	BCK stable interrupt	0
		7	RC	INT_LCK_PLL	PLL lock interrupt	0
		6	RC	INT_OC_BST_P	Predicted boost converter over-current interrupt	0
		5	RC	INT_UV_VBAT	VBAT under-voltage interrupt	0
		4	RC	INT_OV_PVDD	PVDD over-voltage interrupt	0
		3	RC	INT_OC_AMP_P	Amplifier PMOS over-current interrupt	0
		2	RC	INT_OC_AMP_N	Amplifier NMOS over-current interrupt	0
		1	RC	INT_OC_BST	Boost converter over-current interrupt	0
		0	RC	INT_OT	Boost temperature interrupt	0
0x2E	2	15:12		Reserved		
		11	R/W	MSK_INT_LEAK_SPK	Speaker air leak interrupt	0
		10	R/W	MSK_flagResDmg	Speaker's resistance out of range interrupt mask	0
		9	R/W	MSK_flagFreqDmg	Speaker's resonant frequency out of range interrupt mask	0
		8	R/W	MSK_INT_STB_BCK	BCK stable interrupt mask	0
		7	R/W	MSK_INT_LCK_PLL	PLL lock interrupt mask	0
		6	R/W	MSK_INT_OC_BST_P	Predicted boost converter over-current interrupt mask	1
		5	R/W	MSK_INT_UV_VBAT	VBAT under-voltage interrupt mask	1
		4	R/W	MSK_INT_OC_PVDD	PVDD over-voltage interrupt mask	1
		3	R/W	MSK_INT_OC_AMP_P	Amplifier PMOS over-current interrupt mask	1
		2	R/W	MSK_INT_OC_AMP_N	Amplifier NMOS over-current interrupt mask	1
		1	R/W	MSK_INT_OC_BST	Boost converter over-current interrupt mask	1
		0	R/W	MSK_INT_OT	Over-temperature interrupt mask	1

ADDR	Byte	Bits	R/W	Name	Description	Default
0X2F	2	15:12		Reserved		
		11:10	R/W	T_DG_INT_UV_VBAT	INT_UV_VBAT deglitch time 00 : no deglitch 01 : 40ns deglitch 10 : 81ns deglitch 11 : 122ns deglitch	2'b01
		9:8	R/W	T_DG_INT_OV_PVDD	INT_OV_PVDD deglitch time 00 : no deglitch 01 : 40ns deglitch 10 : 81ns deglitch 11 : 122ns deglitch	2'b01
		7:6	R/W	T_DG_INT_OC_AMP_P	INT_OC_AMP_N deglitch time 00 : no deglitch 01 : 40ns deglitch 10 : 81ns deglitch 11 : 122ns deglitch	2'b00
		5:4	R/W	T_DG_INT_OC_AMP_N	INT_OC_AMP_N deglitch time 00 : no deglitch 01 : 40ns deglitch 10 : 81ns deglitch 11 : 122ns deglitch	2'b00
		3:2	R/W	T_DG_INT_OC_BST	INT_OC_BST deglitch time 00 : no deglitch 01 : 40ns deglitch 10 : 81ns deglitch 11 : 122ns deglitch	2'b00
		1:0	R/W	T_DG_INT_OT	INT_OT deglitch time 00 : no deglitch 01 : 40ns deglitch 10 : 81ns deglitch 11 : 122ns deglitch	2'b00
0x30	1	7:4	R/W	SilenceRestTime	Silence reset time : 0 to 15 seconds	4'b0001
		3:0	R/W	sThresAct	Signal Active threshold : 0 to -90dB (sThresAct * -6dB)	4'b1010
0x32	2	15:14		Reserved		
		13:9	R/W	delayGain[4:0]	The gain delay which is used to synchronize left channel and right channel	5'h00
		8:0	R/W	tDelay	Look-ahead delay samples The behavior is undefined if tDelay = 0	9'h64
0x33	1	7:2		Reserved		
		1:0	R/W	tAttackSel	Attack Time Selection : 00 : 0ms 01 : 0.1ms 10 : 0.2ms 11 : 0.3ms	2'b10
0x34	2	15:0	R/W	tRelease	Release Time constant (1-RT)	16'h7fce

ADDR	Byte	Bits	R/W	Name	Description	Default
0x35	2	15:0	R/W	tHoldRelease	Hold Release Time constant (1-RT) <sup>t</sup> Delay	16'h6dd3
0x38	1	7:0	R/W	sThresLmt	Signal threshold for gain limiter 1/128 to 1, 0x80 normalized to 1	8'h80
0x39	1	7:0	R/W	xThresLmt	Excursion threshold for gain limiter 1/128 to 1, 0x80 normalized to 1	8'h80
0x3A	1	7:0	R/W	sThresALC	Signal threshold for automatic gain controller 1/128 to 1, 0x80 normalized to 1	8'h40
0x3B	1	7:0	R/W	xThresALC	Excursion threshold for automatic gain controller 1/128 to 1, 0x80 normalized to 1	8'h40
0x3C	1	7:0	R/W	InitUpDoubleTime	Gain up double time for initial active 1/16 to 15.9375, 0x10 normalized to 1	8'h04
0x3D	1	7:0	R/W	UpDoubleTime	Gain up double time 1/16 to 15.9375, 0x10 normalized to 1	8'h10
0x3E	1	7:0	R/W	DnHalfTime	Gain down half time 1/16 to 15.9375, 0x10 normalized to 1	8'h40
0x3F	1	7:4	R/W	ALCMaxGain	ALC maximum gain -24 to 21dB (ALCMaxGain * 3dB)	4'b0111
		3:0	R/W	ALCInitGain	ALC initial gain -24 to 21dB (ALCInitGain * 3dB)	4'b0000
0x41	1	7:0	R/W	InitImpIDMu	Initial adaptation step size 1/128 to 255/128	8'h04
0x42	1	7:0	R/W	ImpIDMu	Normal adaptation step size 1/2048 to 255/2048	8'h02
0x43	1	7:0	R/W	gPilot	Gain of pilot (in digital domain) 1/4096 to 255/4096 (gPilot*1/16); gPilot = 1/256 to 255/256	8'h11
0x44	1	7:2	R/W	TRXdelay[5:0]		0
		1	R/W	sIPilotEN	Pilot enable in silence mode	0
		0	R/W	PilotEN	Pilot enable	0
0x45	1	7	R/W	Reserved		
		6:4	R/W	PilotScale	Scale-up factor = 2 <sup>PilotScale</sup> to scale up the output of HPF to extract the pilot	0
		3	R/W	iSenseInv	inverse the sign of the current sensing data	0
		2:0	R/W	iSenseScale	Scale-up factor = 2 <sup>iSenseScale</sup> to let CRx/CTx in the range of [1, 2) at calibration phase	0

ADDR	Byte	Bits	R/W	Name	Description	Default
0x46	3	23:0	R/W	iSenseGain	Gain of current sense loop, normalized to 32Ω Read/Write to OTP if SenseGPGMEN = 1 Read/Write to local register if SenseGPGMEN = 0	(MTP)
0x47	3	23:0	R/W	Rapp	Application resistance, normalized to 32Ω	0
0x48	1	7:0	R/W	rMaxExcess	Maximum allowable DCR growth ratio 1/256 to 255/256	0
0x49	2	15:11	R/W	Reserved		
		10:8	R/W	PdictWeightExp	PdictWeight = PdictWeightMant * 2^PdictWeightExp PdictWeightExp = 0 to 7	3'h7
		7:0	R/W	PdictWeightMant	1/128 to 255/128, 0x80 normalized to 1	8'h80
0x4A	2	15:10	R/W	Reserved		
		9:8	R/W	KpExp	Kp = KpMant * 2^KpExp KpExp = 0 to 3	2'h3
		7:0	R/W	KpMant	1/128 to 255/128, 0x80 normalized to 1	8'h80
0x4B	1	7:0	R/W	KiKpRatio	The ratio of Ki/Kp 1/256 to 255/256	8'h3
0x4C	1	7:0	R/W	InitDCRIDMu	Initial adaptation step size 1/256 to 255/256	8'h40
0x4D	1	7:0	R/W	DCRIDMu	Normal adaptation step size 1/1024 to 255/1024	8'h04
0x4E	3	23:0	R/W	CalibDCR	Factory calibrated DC resistor Read/Write to OTP if DCRPGEN = 1 Read/Write to local register if DCRPGEN = 0	(MTP)
0x4F	2	15:0	R/W	CalibBL	Factory calibrated BL factor Read/Write to OTP if BLPGEN = 1 Read/Write to local register if BLPGEN = 0 CalibBL = reg[0x4f] / 2^15	(MTP)
0x50	1	7	R/W	CalibEn	Trigger the calibration to start; self-cleared	0
		0	R	CalibRDY	The calibration output is ready for software reading	0
0x51	2	15:0	R/W	CalibReq	Calibration frequency = round (2 * f_Hz / fs * 65536); fs = 48000	16'h0000
0x52	2	15:0	R/W	GalibGain	Gain of the signal, ranged in [0,1), bit[15] is sign-bit and should be 0 for positive value	16'h0000

ADDR	Byte	Bits	R/W	Name	Description	Default
0x53	4	31:0	R	CalibOut0	Output #1 of calibration data	
0x54	4	31:0	R	CalibOut1	Output #2 of calibration data	
0x55	1	7:0	R/W	xThresLmtDamage	Excursion threshold for gain limiter when damage mode is detected 1/128 to 1, 0x80 normalized to 1	8'h1a
0x56	1	7:0	R/W	rMaxDamage	Maximum allowable DCR growth ratio to regard coil as damaged 1/256 to 255/256	8'hcd
0x57	1	7:0	R/W	fScaleDamage	If the value of SetResFreq/GetResFreq or GetResFreq/SetResFreq is less than this factor, then the diaphragm is regarded as damaged fScaleDamage represents : 1/256 to 255/256	8'h80
0x58	1	7:4	R/W	Reserved		
		3:0	R/W	RecoveryTime	The time to exit the damage mode after the RMAXDMGE or FSCALDMGE criteria is no longer violated. Range for 0 to 15s	0
0x59	2	15:0	R/W	SetResFreq	Preset resonant frequency for damage detection SetResFreq = round (2 * fres / fs * 65536); fs = 48000	16'h889
0x5A	2	15:0	R	GetResFreq	Estimated resonant frequency fres (Hz) = GetResFreq / 65536 * fs / 2	
0x5B	1	2:0	R/W	VOLCTRL	Ramp control when new volume setting is different from old setting : 000 : no ramp up/down 001 : 0.5dB per 4 samples 010 : 0.5dB per 8 samples 011 : 0.5dB per 16 samples 100 : 0.5dB per 32 samples 101 : 0.5dB per 64 samples others : reserved	0
0x5C	1	7:0	R/W	VOLUME	Volume, downward 0 to -127.5dB in -0.5dB step	0
0x5D	4	31:0	R	CalibOutX	Output #2 of calibration X data	
0x5E	4	31:0	R	CalibOutY	Output #2 of calibration Y data	



ADDR	Byte	Bits	R/W	Name	Description	Default
0x5F	4	6:5	R/W	DRC_CUT_LEAKY	00 : 0dB 01 : -3dB 10 : -6dB 11 : -9dB	2'b00
		4	R/W	EN_LMT_LEAK	0 : disable 1 : let xThresLmtDamage to take effect	0
		3:0	R/W	REG_LEAK_THR	Threshold to set the flag of leaky speaker Threshold = REG_LEAK_THR / 128	4'b0000
0x60	20	159:128	R/W	bq_1_b0	u[31:26], b0[25:0]	32'h00000000
		127:96	R/W	bq_1_b1	u[31:26], b1[25:0]	32'h00000000
		95:64	R/W	bq_1_b2	u[31:26], b2[25:0]	32'h00000000
		63:32	R/W	bq_1_a1	u[31:26], a1[25:0]	32'h00000000
		31:0	R/W	bq_1_a2	u[31:26], a2[25:0]	32'h00000000
0x61	20	159:128	R/W	bq_2_b0	u[31:26], b0[25:0]	32'h00800000
		127:96	R/W	bq_2_b1	u[31:26], b1[25:0]	32'h00000000
		95:64	R/W	bq_2_b2	u[31:26], b2[25:0]	32'h00000000
		63:32	R/W	bq_2_a1	u[31:26], a1[25:0]	32'h00000000
		31:0	R/W	bq_2_a2	u[31:26], a2[25:0]	32'h00000000
0x62	20	159:128	R/W	bq_3_b0	u[31:26], b0[25:0]	32'h00800000
		127:96	R/W	bq_3_b1	u[31:26], b1[25:0]	32'h00000000
		95:64	R/W	bq_3_b2	u[31:26], b2[25:0]	32'h00000000
		63:32	R/W	bq_3_a1	u[31:26], a1[25:0]	32'h00000000
		31:0	R/W	bq_3_a2	u[31:26], a2[25:0]	32'h00000000
0x63	20	159:128	R/W	bq_4_b0	u[31:26], b0[25:0]	32'h00800000
		127:96	R/W	bq_4_b1	u[31:26], b1[25:0]	32'h00000000
		95:64	R/W	bq_4_b2	u[31:26], b2[25:0]	32'h00000000
		63:32	R/W	bq_4_a1	u[31:26], a1[25:0]	32'h00000000
		31:0	R/W	bq_4_a2	u[31:26], a2[25:0]	32'h00000000
0x64	20	159:128	R/W	bq_5_b0	u[31:26], b0[25:0]	32'h00800000
		127:96	R/W	bq_5_b1	u[31:26], b1[25:0]	32'h00000000
		95:64	R/W	bq_5_b2	u[31:26], b2[25:0]	32'h00000000
		63:32	R/W	bq_5_a1	u[31:26], a1[25:0]	32'h00000000
		31:0	R/W	bq_5_a2	u[31:26], a2[25:0]	32'h00000000
0x65	20	159:128	R/W	bq_6_b0	u[31:26], b0[25:0]	32'h00800000
		127:96	R/W	bq_6_b1	u[31:26], b1[25:0]	32'h00000000
		95:64	R/W	bq_6_b2	u[31:26], b2[25:0]	32'h00000000
		63:32	R/W	bq_6_a1	u[31:26], a1[25:0]	32'h00000000
		31:0	R/W	bq_6_a2	u[31:26], a2[25:0]	32'h00000000

ADDR	Byte	Bits	R/W	Name	Description	Default
0x66	20	159:128	R/W	bq_7_b0	u[31:26], b0[25:0]	32'h00800000
		127:96	R/W	bq_7_b1	u[31:26], b1[25:0]	32'h00000000
		95:64	R/W	bq_7_b2	u[31:26], b2[25:0]	32'h00000000
		63:32	R/W	bq_7_a1	u[31:26], a1[25:0]	32'h00000000
		31:0	R/W	bq_7_a2	u[31:26], a2[25:0]	32'h00000000
0x67	20	159:128	R/W	bq_8_b0	u[31:26], b0[25:0]	32'h00800000
		127:96	R/W	bq_8_b1	u[31:26], b1[25:0]	32'h00000000
		95:64	R/W	bq_8_b2	u[31:26], b2[25:0]	32'h00000000
		63:32	R/W	bq_8_a1	u[31:26], a1[25:0]	32'h00000000
		31:0	R/W	bq_8_a2	u[31:26], a2[25:0]	32'h00000000
0x68	20	159:128	R/W	bq_9_b0	u[31:26], b0[25:0]	32'h00800000
		127:96	R/W	bq_9_b1	u[31:26], b1[25:0]	32'h00000000
		95:64	R/W	bq_9_b2	u[31:26], b2[25:0]	32'h00000000
		63:32	R/W	bq_9_a1	u[31:26], a1[25:0]	32'h00000000
		31:0	R/W	bq_9_a2	u[31:26], a2[25:0]	32'h00000000
0x69	20	159:128	R/W	bq_10_b0	u[31:26], b0[25:0]	32'h00800000
		127:96	R/W	bq_10_b1	u[31:26], b1[25:0]	32'h00000000
		95:64	R/W	bq_10_b2	u[31:26], b2[25:0]	32'h00000000
		63:32	R/W	bq_10_a1	u[31:26], a1[25:0]	32'h00000000
		31:0	R/W	bq_10_a2	u[31:26], a2[25:0]	32'h00000000
0x6A	20	159:128	R/W	VB_bq_1_b0	u[31:26], b0[25:0]	32'h00800000
		127:96	R/W	VB_bq_1_b1	u[31:26], b1[25:0]	32'h00000000
		95:64	R/W	VB_bq_1_b1	u[31:26], b2[25:0]	32'h00000000
		63:32	R/W	VB_bq_1_b1	u[31:26], a1[25:0]	32'h00000000
		31:0	R/W	VB_bq_1_a2	u[31:26], a2[25:0]	32'h00000000
0x6B	20	159:128	R/W	VB_bq_2_b0	u[31:26], b0[25:0]	32'h00800000
		127:96	R/W	VB_bq_2_b1	u[31:26], b1[25:0]	32'h00000000
		95:64	R/W	VB_bq_2_b1	u[31:26], b2[25:0]	32'h00000000
		63:32	R/W	VB_bq_2_b1	u[31:26], a1[25:0]	32'h00000000
		31:0	R/W	VB_bq_2_a2	u[31:26], a2[25:0]	32'h00000000
0x6C	20	159:128	R/W	VB_bq_3_b0	u[31:26], b0[25:0]	32'h00800000
		127:96	R/W	VB_bq_3_b1	u[31:26], b1[25:0]	32'h00000000
		95:64	R/W	VB_bq_3_b1	u[31:26], b2[25:0]	32'h00000000
		63:32	R/W	VB_bq_3_b1	u[31:26], a1[25:0]	32'h00000000
		31:0	R/W	VB_bq_3_a2	u[31:26], a2[25:0]	32'h00000000

ADDR	Byte	Bits	R/W	Name	Description	Default
0x6D	20	159:128	R/W	VB_bq_4_b0	u[31:26], b0[25:0]	32'h00800000
		127:96	R/W	VB_bq_4_b1	u[31:26], b1[25:0]	32'h00000000
		95:64	R/W	VB_bq_4_b1	u[31:26], b2[25:0]	32'h00000000
		63:32	R/W	VB_bq_4_b1	u[31:26], a1[25:0]	32'h00000000
		31:0	R/W	VB_bq_4_a2	u[31:26], a2[25:0]	32'h00000000
0x6E	20	159:128	R/W	VB_bq_5_b0	u[31:26], b0[25:0]	32'h00800000
		127:96	R/W	VB_bq_5_b1	u[31:26], b1[25:0]	32'h00000000
		95:64	R/W	VB_bq_5_b1	u[31:26], b2[25:0]	32'h00000000
		63:32	R/W	VB_bq_5_b1	u[31:26], a1[25:0]	32'h00000000
		31:0	R/W	VB_bq_5_a2	u[31:26], a2[25:0]	32'h00000000
0x6F	20	159:128	R/W	VB_bq_6_b0	u[31:26], b0[25:0]	32'h00800000
		127:96	R/W	VB_bq_6_b1	u[31:26], b1[25:0]	32'h00000000
		95:64	R/W	VB_bq_6_b1	u[31:26], b2[25:0]	32'h00000000
		63:32	R/W	VB_bq_6_b1	u[31:26], a1[25:0]	32'h00000000
		31:0	R/W	VB_bq_6_a2	u[31:26], a2[25:0]	32'h00000000
0x70	20	159:128	R/W	VB_bq_7_b0	u[31:26], b0[25:0]	32'h00800000
		127:96	R/W	VB_bq_7_b1	u[31:26], b1[25:0]	32'h00000000
		95:64	R/W	VB_bq_7_b1	u[31:26], b2[25:0]	32'h00000000
		63:32	R/W	VB_bq_7_b1	u[31:26], a1[25:0]	32'h00000000
		31:0	R/W	VB_bq_7_a2	u[31:26], a2[25:0]	32'h00000000
0x71	20	159:128	R/W	VB_bq_8_b0	u[31:26], b0[25:0]	32'h00800000
		127:96	R/W	VB_bq_8_b1	u[31:26], b1[25:0]	32'h00000000
		95:64	R/W	VB_bq_8_b1	u[31:26], b2[25:0]	32'h00000000
		63:32	R/W	VB_bq_8_b1	u[31:26], a1[25:0]	32'h00000000
		31:0	R/W	VB_bq_8_a2	u[31:26], a2[25:0]	32'h00000000
0x72	20	159:128	R/W	VB_bq_9_b0	u[31:26], b0[25:0]	32'h00800000
		127:96	R/W	VB_bq_9_b1	u[31:26], b1[25:0]	32'h00000000
		95:64	R/W	VB_bq_9_b1	u[31:26], b2[25:0]	32'h00000000
		63:32	R/W	VB_bq_9_b1	u[31:26], a1[25:0]	32'h00000000
		31:0	R/W	VB_bq_9_a2	u[31:26], a2[25:0]	32'h00000000
0x73	24	191:160	R/W	VB_fcn_a0	u[31:26], a0[25:0]	32'h00800000
		159:128	R/W	VB_fcn_a1	u[31:26], a1[25:0]	32'h00000000
		127:96	R/W	VB_fcn_a2	u[31:26], a2[25:0]	32'h00000000
		95:64	R/W	VB_fcn_b0	u[31:26], b0[25:0]	32'h00800000
		63:32	R/W	VB_fcn_b1	u[31:26], b1[25:0]	32'h00000000
		31:0	R/W	VB_fcn_b2	u[31:26], b2[25:0]	32'h00000000
0x75	4	31:0	R/W	VB_GAIN_2[25:0]	u[31:26], gain1[25:0]	32'h00800000
0x76	4	31:0	R/W	VB_GAIN_3[25:0]	u[31:26], gain1[25:0]	32'h00800000

ADDR	Byte	Bits	R/W	Name	Description	Default
0x77	4	31:0	R/W	VB_GAIN_4[25:0]	u[31:26], gain1[25:0]	32'h00800000
0x78	4	31:0	R/W	VB_GAIN_5[25:0]	u[31:26], gain1[25:0]	32'h00800000
0x79	4	31:0	R/W	VB_GAIN_6[25:0]	u[31:26], gain1[25:0]	32'h00800000
0x7A	4	31:0	R/W	VB_GAIN_7[25:0]	u[31:26], gain1[25:0]	32'h00800000
0x7B	4	31:0	R/W	VB_GAIN_8[25:0]	u[31:26], gain1[25:0]	32'h00800000
0x7C	4	31:0	R/W	VB_GAIN_9[25:0]	u[31:26], gain1[25:0]	32'h00800000
0x7D	4	31:0	R/W	VB_GAIN_10[25:0]	u[31:26], gain1[25:0]	32'h00800000
0x7E	1	7	R/W	PALPF4EN	2 <sup>nd</sup> Biquad enable	0
		6		Reversed		
		5:4	R/W	CONSTANT [1:0]		2'b00
		3:0	R/W	SLOP [3:0]		4'b0000
0x7F	1	7:0	R/W	BW_COEFF[7:0]	Default : 0dB, 0.5dB per steps Increase setting will decrease output gain Decrease setting will increase	8'h30
0x80	1	7	R/W	SW_RESET	1 : Software Reset	0
		0		Reserved		0
0x81	1	7:5		D_SPK_BOOST[2:0]	Class D gain control [000:110] = 0 to 15db/3db	3'b100
		4:0		D_SPKLPF_VOL[4:0]	PGA Feedback Gain control RF [0000 to 1111] = -31db to 0db/1db	4'b10111
0x82	1	1:0	R/W	D_PGA_SPKPGA_VOL [1:0]	PGA Input Gain control 00 = -6dB 01 = -3dB 10 = 0dB 11 = 3dB	2'b10
0x86	1	7	R/W	D_VMID_EN	VMID enable (AVDD/2)	0
		6	R/W	D_VMID_FAST	VMID quick charge	0
0x88	1	7	R/W	D_CS_EN	Current sense enable	0
0x8B	2	15:0	R/W	vbat_data[15:0]	Read mode : read vbat_data value from vbt_sens Write mode : when 0xC8 vbat_data_tst_en is set to 1, vbat_data is from this register	16'h0000
0x8C	2	15:0	R/W	vtherm_data[15:0]	read mode : read vtherm_data value from vbt_sens write mode : when 0xC8 vtherm_data_tst_en is set to 1, vtherm_data is from this register	16'h0000

ADDR	Byte	Bits	R/W	Name	Description	Default
0x8D	1	5	R/W	vbt_sense_auto_en	Battery/Temperature auto sense enable : 1 : enable battery/temperature auto sense 0 : disable	0
		4:2	R/W	vbt_sense_time_sel[2:0]	Battery/Temperature sense period : 000 : sense every 16ms 001 : sense every 32ms 010 : sense every 64ms 011 : sense every 128ms 100 : sense every 256ms 101 : sense every 512ms 110 : sense every 1024ms 111 : sense every 2048ms	3'b000
		1:0	R/W	vbt_sense_clk_sel[1:0]	Battery/Temperature sense ADC clock frequency selection : 00 : 384KHz 01 : 192KHz 10 : 96KHz 11 : 48KHz	2'b00
0x96	1	7	R/W	ovp_prot_en	OVP protection enable : 1 : enable ovp protection 0 : disable	0
		6	R/W	uvp_prot_en	UVP protection enable : 1 : enable uvp protection 0 : disable	0
		5	R/W	cd_ocp_prot_en	Class-D OCP protection enable : 1 : enable Class-D OCP protection 0 : disable	0
0x97	1	0	R/W	PLL_FREERUN	1 : PLL free run mode	1
0x99	1	3:2	R/W	PLL_CKSEL[1:0]	Select the output to PLL_CKOUT pin(debug & meas.) 2'b00 -> CKOUT (24.576M, 22.5792M) 2'b01 -> CKOUT/2 (24.576M/2, 22.5792M/2) 2'b10 -> PLL_CKOUT = FREF 2'b11 -> PLL_CKOUT = FREF (reserved)	0
		1:0	R/W	PLL_RDYSEL[1:0]	PLL/FLL output ready 2'b00 -> PLL_RDY = CLK_RDY 2'b01 -> PLL_RDY = (preserved) 2'b10 -> PLL_RDY = SHIFTGAIN_RDY 2'b11 -> PLL_RDY = SHIFTGAIN_RDY (preserved)	0

ADDR	Byte	Bits	R/W	Name	Description	Default
0x9A	1	5:4	R/W	PLL_BW_RATIO	Kp / Ki ratio : 2'b00 -> Kp = 1; Ki = 1/8 2'b01 -> Kp = 1; Ki = 1/16 2'b10 -> Kp = 1; Ki = 1/32 2'b11 -> Kp = 1; Ki = 1/64	2'b01
		3	R/W	PLL_DZONE_MODE	dead-zone mode : 1 : accumlate Kp path, larger BW. 0 : skip Ki path, smaller BW.	1
		2	R/W	PLL_NDSM_MODE	DSM order for fractional-N mode 0 : 1 <sup>st</sup> order 1 : 2 <sup>nd</sup> order	1
		1:0	R/W	PLL_REF_DIV[1:0]	Input reference frequency divided ratio 2'b00 -> FREF 2'b01 -> FREF/2 2'b10 -> FREF/4 2'b11 -> FREF/8	2'b00
0x9B	1	5	R	CK_CMPOUT_IDAC2	Boost voltage loop comparator output	
		4	R	CK_ISENSE_FLAG	Boost current loop comparator output	
		3:1	R	LOCK_DET[2:0]	The value of phase error (log scale)	
		0	R	PLL_RDY	PLL is ready. Its source is based on PLL_RDYSEL[1:0]	
0x9C	4	31:29		Reserved		
		28:16	R/W	PLL_N_I	PLL frequency disivor, integer part. {PLL_N_I, PLL_N_F} is a unsigned number in u13.16 format, which specifies the ratio of nominal system clock (~ 24MHz) over reference clock frequency.	13'h0008
		15:0	R/W	PLL_N_F	PLL frequency disivor, fractional part.	16'h0000
0x9F	1	6	R/W	I <sup>2</sup> S_LOSS_DET_EN	1 : Enable LRCK/BCK loss check	0
		5	R/W	I <sup>2</sup> C_TIME_OUT_SEL	1 : Reset Chip if I <sup>2</sup> C timeout and check function enable	0
		4	R/W	I <sup>2</sup> C_TIME_OUT	1 : Enable I <sup>2</sup> C time out check	0
		3	R	BCK_LOSS	1 : BCK loss	0
		2	R	LRCK_LOSS	1 : LRCK loss	0

ADDR	Byte	Bits	R/W	Name	Description	Default
		7:6		Reserved		
0xA2	1	4:0	R/W	spk_rpt_sel[4:0]	0x00 : limiter gain = spk_rpt * 16 0x01 : ALC gain = spk_rpt * 16 0x02 : gain information = spk_rpt 0x03 : voltage output w/o pilot = spk_rpt * 16 0x04 : voltage output w/l pilot = spk_rpt 0x05 : corrent sense result = spk_rpt 0x06 : (voltage output w/l pilot)*current sense = spk_rpt * 16 0x07 : ATC gain = spk_rpt * 16 0x08 : voltage delay = spk_rpt * 16 0x09: Estimated current = spk_rpt * 16 0x0a : Estimated current error = spk_rpt * 16 0x0b : Estimated velocity = spk_rpt * 16 0x0c : Estimated excursion = spk_rpt * 16 0x0d : Estimated Resistor = spk_rpt * 16 0x0e : input signal peak = spk_rpt * 16 0x0f : excursion peak = spk_rpt * 16 0x10 : phi1 = spk_rpt * 16π 0x11 : phi2 = spk_rpt * 16π 0x12 : phi3 = spk_rpt * 16π 0x13 : phi4 = spk_rpt * 16π 0x14 : phi5 = spk_rpt * 16π 0x15 : adaptive b0 = spk_rpt * 16 0x16 : adaptive b1 = spk_rpt * 16 0x17 : adaptive b2 = spk_rpt * 16 0x18 : adaptive b3 = spk_rpt * 16 0x19 : adaptive b4 = spk_rpt * 16 0x1a : adaptive b5 = spk_rpt * 16 0x1b : tx_data = spk_rpt 0x1c : rx_pilot = spk_rpt 0x1d : tx_pilot = spk_rpt 0x1e : digital maximum allowable absolute data = spk_rpt * 16 0x1f : single_tone = spk_rpt[23] active = spk_rpt[22] silence = spk_rpt[21] dmgRes = spk_rpt[20] dmgFreq = spk_rpt[19] damage = spk_rpt[18] acq = spk_rpt[17] spkE = spk_rpt[16] cntr10ms = spk_rpt[8:0]	5'h02

ADDR	Byte	Bits	R/W	Name	Description	Default
0xA3	3	23:0	R	spk_rpt[23:0]	Format : Q0.23, please refer to spk_rpt_sel	
0xA4	3	23:0	R/W	nDelay[23:0]	The delay added to the output voltage of SPKFB for synchronization. nDelay = reg[0xa4] / 2 <sup>21</sup> The range is [-2, 3) with 21 fractional bits.	0
0xA5	3	23:0	R/W	res[23:0]	The initial value of the parameter which is proportional to the resistance. Resistance = reg[0xa5] / 2 <sup>23</sup> The range is [0, 2) with 23 fractional bits.	24'h800000
0xA6	3	23:0	R/W	phi1[23:0]	The initial value of the radians for the adaptive filter. The radians π/2 is normalized to 1/2, and the range is [-0.5, 0.5] with 23 fractional bits. Phi1 c = reg[a6] / 2 <sup>23</sup> * pi	24'hC4266F
0xA7	3	23:0	R/W	phi2[23:0]		24'h345F58
0xA8	3	23:0	R/W	phi3[23:0]		24'hFE21CB
0xA9	3	23:0	R/W	phi4[23:0]		24'h000000
0xAA	3	23:0	R/W	phi5[23:0]		24'h000000
0xAB	3	23:0	R/W	Adptive_b0[23:0]		The initial value of the expansion coefficient for the adaptive filter. The range is [-2, 2) with 22 fractional bits. B0 = reg[ab] / 2 <sup>22</sup>
0xAC	3	23:0	R/W	Adptive_b1[23:0]	24'hF1EBC8	
0xAD	3	23:0	R/W	Adptive_b2[23:0]	24'h33BD58	
0xAE	3	23:0	R/W	Adptive_b3[23:0]	24'h309E9	
0xAF	3	23:0	R/W	Adptive_b4[23:0]	24'h000000	
0xB0	3	23:0	R/W	Adptive_b5[23:0]	24'h000000	
0xB4	1	7	R/W	OTP_PLL_LOCK_IGNORE	Access MTP memory without PLL lock	0
		5:4	R/W	D_IB_IDAC2	Boost block Bias current option 00 = 1.25μ 01 = 2.5μ 10 = 3.75μ 11 = 5μ	2'b01
		3	R/W	TDM_EN	I <sup>2</sup> S TDM enable bit	0
		2	R/W	TDM_ADC_SEL	I <sup>2</sup> S ADC TDM slot selection	0
		1	R/W	TDM_DAC_SEL	I <sup>2</sup> S DAC TDM slot selection	0
		0	R/W	dcrEstInSilMod	Do DCR estimation when act signal is not logic 0	0
0xCF	1	7:0	R/W	DRC_MIN_GAIN		8'hFF
0xD0	1	7:4	R/W	Reserved		2'b00
		3:0	R/W	DRC_SET_SEL[3:0]	0000 : DRC1 0001 : DRC2 0010 : DRC3 0011 : DRC4 0100 : DRC5 other : no define	4'h0



ADDR	Byte	Bits	R/W	Name	Description	Default
0xD1	16	127:122		Reserved		
		121:96	R/W	DRC_AE	DRC_AE[25:0]	26'h0800000
		95:90		Reserved		
		89:64	R/W	DRC_1_AE	DRC_1_AE[25:0]	26'h0000000
		63:58		Reserved		
		57:32	R/W	DRC_AA	DRC_AA[25:0]	26'h0800000
		31:26		Reserved		
		25:0	R/W	DRC_AD	DRC_AD[25:0]	26'h0800000
0xD2	7	55	R/W	DRC_RMS	0 : RMS 1 : Peak	0
		54:52	R/W	DRC_KNEE[2:0]		3'b000
		51:50		Reserved		
		49:40	R/W	DRC_TH0[9:0]	1. 0 to -127dB, 0.125dB per step 2. 10'h000 is 0dB 3. value definiton is 7.3	10'h000
		39:34		Reserved		
		33:24	R/W	DRC_TH1[9:0]	1. 0 to -127dB, 0.125dB per step 2. 10'h000 is 0dB	10'h000
		23:16	R/W	DRC_OFF[7:0]	1. +24dB to -24dB 2. 0.25dB per step 3. value definiton is 6.2, MSB is sign bit.	8'h00
		15:13		Reserved		
		12:8	R/W	DRC_R0[4:0]	1. 0 to 1 2. 5'h10 is 1	5'h10
		7		Reserved		
		6:0	R/W	DRC_R1[6:0]	1. 1 to 8 2. 7'h10 is 1	7'h10
0xD3	20	159:128	R/W	bq_1_b0	u[31:26], b0[25:0]	32'h00800000
		127:96	R/W	bq_1_b1	u[31:26], b1[25:0]	32'h00000000
		95:64	R/W	bq_1_b2	u[31:26], b2[25:0]	32'h00000000
		63:32	R/W	bq_1_a1	u[31:26], a1[25:0]	32'h00000000
		31:0	R/W	bq_1_a2	u[31:26], a2[25:0]	32'h00000000
0xD4	20	159:128	R/W	bq_2_b0	u[31:26], b0[25:0]	32'h00800000
		127:96	R/W	bq_2_b1	u[31:26], b1[25:0]	32'h00000000
		95:64	R/W	bq_2_b2	u[31:26], b2[25:0]	32'h00000000
		63:32	R/W	bq_2_a1	u[31:26], a1[25:0]	32'h00000000
		31:0	R/W	bq_2_a2	u[31:26], a2[25:0]	32'h00000000

ADDR	Byte	Bits	R/W	Name	Description	Default
0xD5	20	159:128	R/W	bq_3_b0	u[31:26], b0[25:0]	32'h00800000
		127:96	R/W	bq_3_b1	u[31:26], b1[25:0]	32'h00000000
		95:64	R/W	bq_3_b2	u[31:26], b2[25:0]	32'h00000000
		63:32	R/W	bq_3_a1	u[31:26], a1[25:0]	32'h00000000
		31:0	R/W	bq_3_a2	u[31:26], a2[25:0]	32'h00000000
0xD6	20	159:128	R/W	bq_4_b0	u[31:26], b0[25:0]	32'h00800000
		127:96	R/W	bq_4_b1	u[31:26], b1[25:0]	32'h00000000
		95:64	R/W	bq_4_b2	u[31:26], b2[25:0]	32'h00000000
		63:32	R/W	bq_4_a1	u[31:26], a1[25:0]	32'h00000000
		31:0	R/W	bq_4_a2	u[31:26], a2[25:0]	32'h00000000
0xD7	20	159:128	R/W	bq_5_b0	u[31:26], b0[25:0]	32'h00800000
		127:96	R/W	bq_5_b1	u[31:26], b1[25:0]	32'h00000000
		95:64	R/W	bq_5_b2	u[31:26], b2[25:0]	32'h00000000
		63:32	R/W	bq_5_a1	u[31:26], a1[25:0]	32'h00000000
		31:0	R/W	bq_5_a2	u[31:26], a2[25:0]	32'h00000000
0xD8	20	159:128	R/W	bq_6_b0	u[31:26], b0[25:0]	32'h00800000
		127:96	R/W	bq_6_b1	u[31:26], b1[25:0]	32'h00000000
		95:64	R/W	bq_6_b2	u[31:26], b2[25:0]	32'h00000000
		63:32	R/W	bq_6_a1	u[31:26], a1[25:0]	32'h00000000
		31:0	R/W	bq_6_a2	u[31:26], a2[25:0]	32'h00000000
0xD9	20	159:128	R/W	bq_7_b0	u[31:26], b0[25:0]	32'h00800000
		127:96	R/W	bq_7_b1	u[31:26], b1[25:0]	32'h00000000
		95:64	R/W	bq_7_b2	u[31:26], b2[25:0]	32'h00000000
		63:32	R/W	bq_7_a1	u[31:26], a1[25:0]	32'h00000000
		31:0	R/W	bq_7_a2	u[31:26], a2[25:0]	32'h00000000
0xDA	20	159:128	R/W	bq_8_b0	u[31:26], b0[25:0]	32'h00800000
		127:96	R/W	bq_8_b1	u[31:26], b1[25:0]	32'h00000000
		95:64	R/W	bq_8_b2	u[31:26], b2[25:0]	32'h00000000
		63:32	R/W	bq_8_a1	u[31:26], a1[25:0]	32'h00000000
		31:0	R/W	bq_8_a2	u[31:26], a2[25:0]	32'h00000000
0xDB	20	159:128	R/W	bq_9_b0	u[31:26], b0[25:0]	32'h00800000
		127:96	R/W	bq_9_b1	u[31:26], b1[25:0]	32'h00000000
		95:64	R/W	bq_9_b2	u[31:26], b2[25:0]	32'h00000000
		63:32	R/W	bq_9_a1	u[31:26], a1[25:0]	32'h00000000
		31:0	R/W	bq_9_a2	u[31:26], a2[25:0]	32'h00000000

ADDR	Byte	Bits	R/W	Name	Description	Default
0xDC	20	159:128	R/W	bq_10_b0	u[31:26], b0[25:0]	32'h00800000
		127:96	R/W	bq_10_b1	u[31:26], b1[25:0]	32'h00000000
		95:64	R/W	bq_10_b2	u[31:26], b2[25:0]	32'h00000000
		63:32	R/W	bq_10_a1	u[31:26], a1[25:0]	32'h00000000
		31:0	R/W	bq_10_a2	u[31:26], a2[25:0]	32'h00000000
0xDD	20	159:128	R/W	bq_11_b0	u[31:26], b0[25:0]	32'h00800000
		127:96	R/W	bq_11_b1	u[31:26], b1[25:0]	32'h00000000
		95:64	R/W	bq_11_b2	u[31:26], b2[25:0]	32'h00000000
		63:32	R/W	bq_11_a1	u[31:26], a1[25:0]	32'h00000000
		31:0	R/W	bq_11_a2	u[31:26], a2[25:0]	32'h00000000
0xDE	20	159:128	R/W	bq_12_b0	u[31:26], b0[25:0]	32'h00800000
		127:96	R/W	bq_12_b1	u[31:26], b1[25:0]	32'h00000000
		95:64	R/W	bq_12_b2	u[31:26], b2[25:0]	32'h00000000
		63:32	R/W	bq_12_a1	u[31:26], a1[25:0]	32'h00000000
		31:0	R/W	bq_12_a2	u[31:26], a2[25:0]	32'h00000000
0xDF	2	15	R/W	DC_CUT_FILTER_DIS	1 : Disable DC-Cut filter	0
		14	R/W	H_BAND_BYPASS	1 : Bypass High band DRC	0
		13	R/W	M_BAND_BYPASS	1 : Bypass Middle band DRC	0
		12	R/W	L_BAND_BYPASS	1 : Bypass Low band DRC	0
		11:10		Reserved		
		9	R/W	SideChain_2_ON	1 : Enable sidchain for low band DRC	0
		8	R/W	SideChain_1_ON	1 : Enable sidchain for Middle band DRC	0
		7:5		Reserved		0
		4	R/W	DRC5_EN	1 : DRC5 enable	0
		3	R/W	DRC4_EN	1 : DRC4 enable	0
		2	R/W	DRC3_EN	1 : DRC3 enable	0
		1	R/W	DRC2_EN	1 : DRC2 enable	0
		0	R/W	DRC1_EN	1 : DRC1 enable	0
0xF4	1	7	R/W	FDRC_CK_EN	1 : enable FDRC block clock	1
		6	R/W	BOOST_CK_EN	1 : enable BOOST block clock	1
		5	R/W	ADC_CK_EN	1 : enable ADC block clock	1
		4	R/W	DAC_CK_EN	1 : enable DAC block clock	1
		3	R/W	SSRC_CK_EN	1 : enable SSRC block clock	1
		2	R/W	DSP_CK_EN	1 : enable DSP block clock	1
		1	R/W	SPK_CK_EN	1 : enable SPK Protection block clock	1
		0	R/W	ANA_CK_EN	1 : enable analog block clock	1

ADDR	Byte	Bits	R/W	Name	Description	Default
0xF5	1	7:2	R/W	Reserved		6'h00
		1	R/W	SAFE_GUARD_CK_EN	1 : enable SAFE Guard block clock	1
		0	R/W	CAL_CK_EN	1 : enable Cal block clock	1

**Application Information**

**Inductor Selection**

The recommended value of inductor for DC-to-DC boost converter applications is 1μH. Small size and better efficiency are the major concerns for portable devices, such as the RT5509 used for mobile phone. The inductor should have low core loss at 1MHz (Min.) and low DCR for better efficiency.

The maximum current of inductor is highly depends on the speaker impedance which determines the output current of the boost converter. The inductor saturation

current rating should be considered to cover the inductor peak current which can be approximated by the following equation :

$$I_{L\_max} = \frac{V_{OUT} \times I_{OUT}}{\eta \times V_{IN}} + \frac{V_{IN} \times D \times T_S}{2 \times L_{Boost}}$$

Following is the inductor selection reference for typical speaker impedances with 10% tolerance and 95% efficient.

R <sub>L</sub> (Ω)	I <sub>OUT</sub> (A)	I <sub>L_MAX</sub> (A)	Manufacturer	Part Number
8	1.14	1.43	Murata	MDT2520-CN1ROM
6	1.52	1.81	Coilcraft	PFL2512-102MEB
4	2.28	2.57	Coilcraft	LPS4012-102NLB

**Capacitor Selection**

For low ripple voltage, ceramic capacitors with low ESR are recommended. A real (as opposed to ideal) capacitor can be modeled simply as a resistor in series with an ideal capacitor. The voltage drop across this resistor minimizes the beneficial effects of the capacitor in the circuit. X5R and X7R types are suitable because

of their wide voltage range and good operating temperature characteristics. The capacitance value decreases over the DC-biasing voltage range (30% to 70% decrease) as following figure. Consequently, the nominal value of the capacitor should be close to twice the minimum value specified

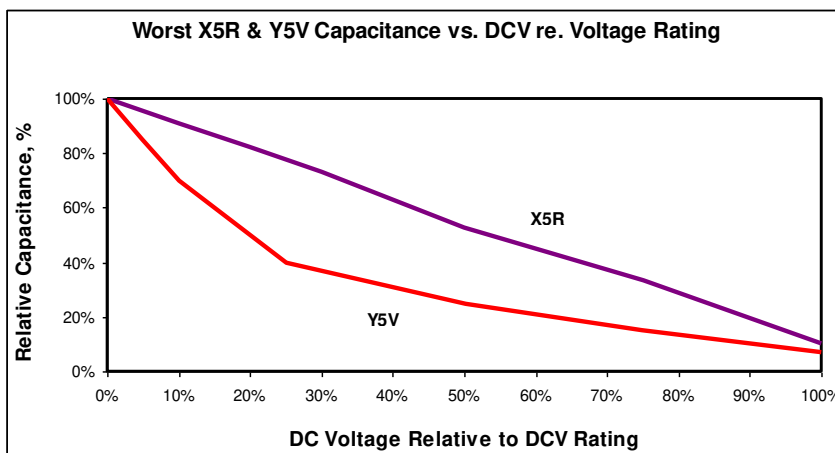

The output ripple can be determined as following equation :

$$\Delta V_{OUT} = \frac{D \times I_{OUT} \times T_S}{\eta \times C_{OUT}} + \left( \frac{I_{OUT}}{1-D} + \frac{V_{IN} \times D \times T_S}{2 \times L_{Boost}} \right) \times r_{C\_esr}$$

For the application of the RT5509 to boost VBAT to 9.5V, a 10µF for input capacitor, an 22µF for boost capacitor and a 100nF for DVDD decoupling capacitor are recommended.

Boost capacitor connect to BST is important for stability. The C<sub>PVDD</sub> capacitance is changed by DC bias. When select capacitor, please notice the DC bias characteristics. The RT5509 minimum recommended C<sub>PVDD</sub> capacitance is 6µF for output power 3.6W, C<sub>PVDD</sub> capacitance is 8µF for output power 4.3W.

**Filter Free Operation and Ferrite Bead Filters**

A ferrite bead filter can often be used if the design is failing radiated emissions without an LC filter and the frequency sensitive circuit is greater than 1MHz. This filter functions well for circuits that just have to pass FCC and CE because FCC and CE only test radiated emissions greater than 30MHz. When choosing a ferrite bead, choose one with high impedance at high frequencies, and low impedance at low frequencies. Typically, impedance rises over 150Ω before 30MHz to provide at least -20dB decade is minimum requirement (such as TDK : MPZ1608S221A) Figure 21. In addition, select a ferrite bead with adequate current rating to prevent distortion of the output signal.

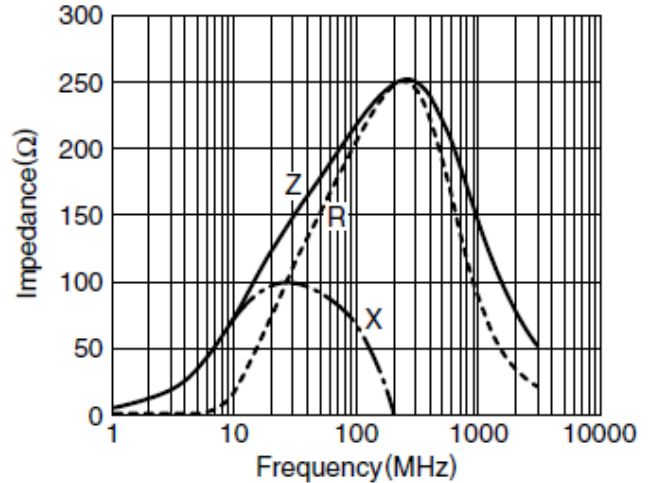

Figure 21. Impedance of MPZ1608S221A

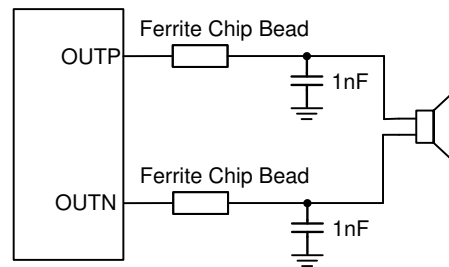

Figure 22. Typical Ferrite Chip Bead Filter

**Thermal Considerations**

The junction temperature should never exceed the absolute maximum junction temperature T<sub>J(MAX)</sub>, listed under Absolute Maximum Ratings, to avoid permanent damage to the device. The maximum allowable power dissipation depends on the thermal resistance of the IC package, the PCB layout, the rate of surrounding airflow, and the difference between the junction and ambient temperatures. The maximum power dissipation can be calculated using the following formula :

$$P_{D(MAX)} = (T_{J(MAX)} - T_A) / \theta_{JA}$$

where T<sub>J(MAX)</sub> is the maximum junction temperature, T<sub>A</sub> is the ambient temperature, and θ<sub>JA</sub> is the junction-to-ambient thermal resistance.

For continuous operation, the maximum operating junction temperature indicated under Recommended Operating Conditions is 125°C. The junction-to-ambient thermal resistance, θ<sub>JA</sub>, is highly package dependent. For WL-CSP-48B 3.04x2.99 (BSC)

package, the thermal resistance,  $\theta_{JA}$ , is  $27^{\circ}\text{C/W}$  on a standard JEDEC 51-7 high effective-thermal-conductivity four-layer test board. The maximum power dissipation at  $T_A = 25^{\circ}\text{C}$  can be calculated as below :

$$P_{D(\text{MAX})} = (125^{\circ}\text{C} - 25^{\circ}\text{C}) / (27^{\circ}\text{C/W}) = 3.7\text{W for a WL-CSP-48B } 3.04 \times 2.99 \text{ (BSC) package}$$

The maximum power dissipation depends on the operating ambient temperature for the fixed  $T_{J(\text{MAX})}$  and the thermal resistance,  $\theta_{JA}$ . The derating curve in Figure 23 allows the designer to see the effect of rising ambient temperature on the maximum power dissipation.

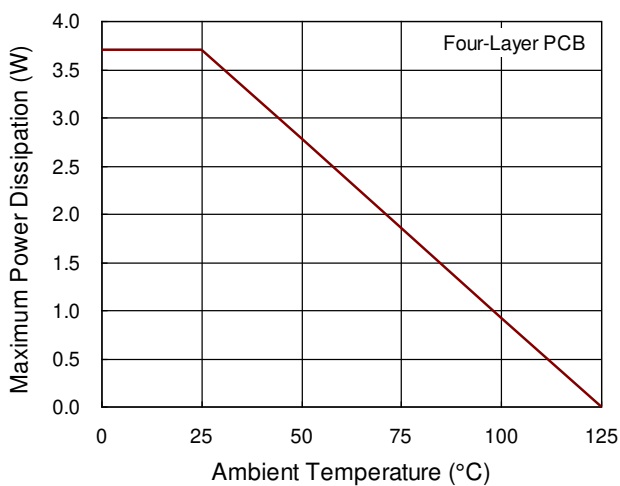

Figure 23. Derating Curve of Maximum Power Dissipation

**Layout Consideration**

For best performance of the RT5509, the below PCB Layout guidelines must be strictly followed.

For achieving good quality, the traces of VSPOUTP and VSPOUTN should be kept equal width and length respectively. The Bead + C should be placed close to chip for better EMI performance. The power trace of boost inductor is suggested to place on the external layers for higher current capability. Please place the inductor as close as possible to the chip.

For achieving good audio quality, must place the decoupling capacitors as close as possible to the DVDD pins and ground connection link to DGND and AGND first before going to GND plane, the trace width of DVDD is 6mil at least. 1.8V source provide other device power in the system. If power trace layout was not well, that can adversely affect their own.

To prevent this problem, Star connection used from DVDD power source to DVDD directly.

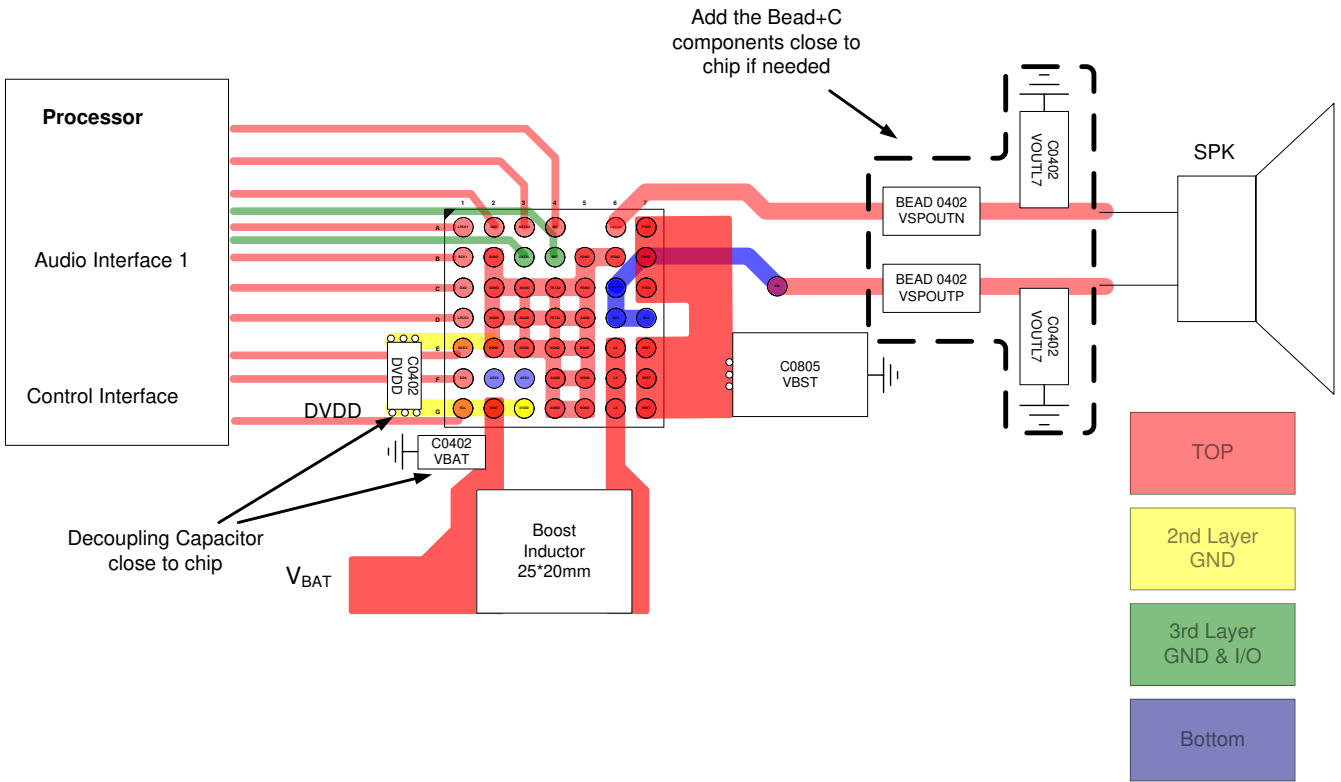

Figure 24. PCB Layout Guide

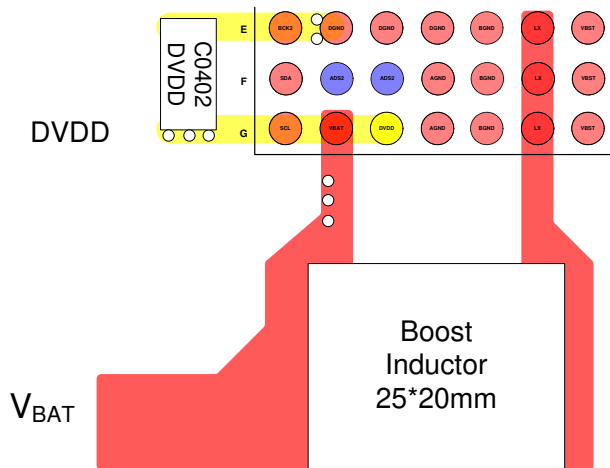
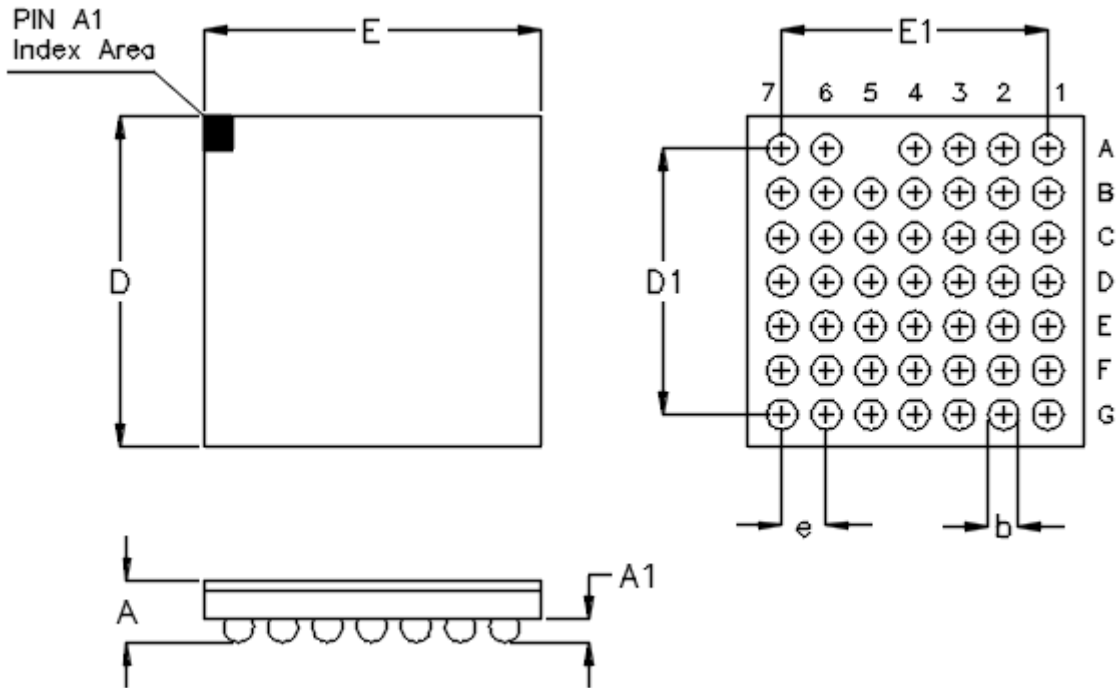

Figure 25. DVDD Layout Suggestion



**Outline Dimension**



Symbol	Dimensions In Millimeters		Dimensions In Inches	
	Min	Max	Min	Max
A	0.500	0.600	0.020	0.024
A1	0.170	0.230	0.007	0.009
b	0.240	0.300	0.009	0.012
D	2.950	3.030	0.116	0.119
D1	2.400		0.094	
E	3.000	3.080	0.118	0.121
E1	2.400		0.094	
e	0.400		0.016	

**48B WL-CSP 3.04x2.99 Package (BSC)**

Footprint Information

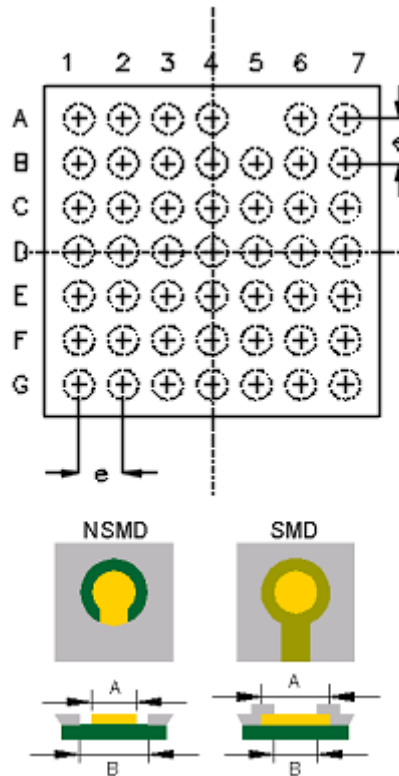

Package	Number of Pin	Type	Footprint Dimension (mm)			Tolerance
			e	A	B	
WL-CSP3.04x2.99-48(BSC)	48	NSMD	0.400	0.240	0.340	±0.025
		SMD		0.270	0.240	

**Richtek Technology Corporation**

14F, No. 8, Tai Yuen 1<sup>st</sup> Street, Chupei City  
 Hsinchu, Taiwan, R.O.C.  
 Tel: (8863)5526789

Richtek products are sold by description only. Richtek reserves the right to change the circuitry and/or specifications without notice at any time. Customers should obtain the latest relevant information and data sheets before placing orders and should verify that such information is current and complete. Richtek cannot assume responsibility for use of any circuitry other than circuitry entirely embodied in a Richtek product. Information furnished by Richtek is believed to be accurate and reliable. However, no responsibility is assumed by Richtek or its subsidiaries for its use; nor for any infringements of patents or other rights of third parties which may result from its use. No license is granted by implication or otherwise under any patent or patent rights of Richtek or its subsidiaries.

Copyright © 2017 Richtek Technology Corporation. All rights reserved. **RICHTEK** is a registered trademark of Richtek Technology Corporation