

Thermofit Molded Parts Specification Control Drawing

Part Number : 602A012
Description : Transition, 1 To 5

NOTES

- All dimensions are in $\frac{\text{inches}}{\text{millimeters}}$
- Dimensions appearing in table are as follows:
 - a - As Supplied
 - b - After Unrestricted Recovery
- Coating is optional. As supplied dimensions appearing in table are for uncoated parts. When coating is added, entry diameters will be reduced by .06 max.

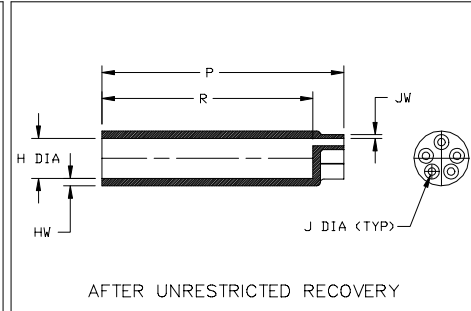
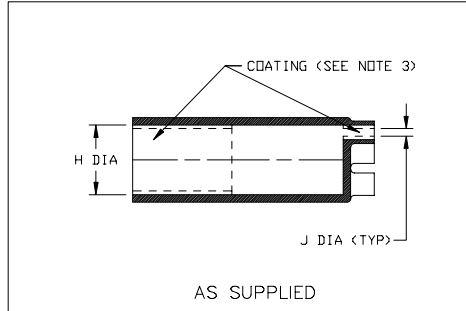

TABLE OF DIMENSIONS								
PART NUMBER	H		J		P	R	HW	JW
	Min a	Max b	Min a	Max b	±10% b	±10% b	±20% b	±20% b
602A012	.56 [14,2]	.36 [9,1]	.12 [3,0]	.07 [1,7]	2.20 [55,8]	1.95 [49,5]	.06 [1,5]	.03 [0,76]

If this document is printed it becomes uncontrolled.
Check for the latest revision.

Raychem

RAYCHEM CORPORATION
300 CONSTITUTION DRIVE
MENLO PARK, CALIFORNIA 94025

Revision : D
Date : 2/12/97

Part Number : 602A012
Description : Transition, 1 To 5

Thermofit Molded Parts Specification Control Drawing

Part Number : 602A012
Description : Transition, 1 To 5

COMPATABILITY CHART					
MATERIAL DASH NO.	MATERIAL DESCRIPTION	RT SPEC	COATING SLASH NO.	COATING S NO.	COATING DESCRIPTION
-3	Polyolefin, Semi-rigid	RT-301	/42;/86	S-1017;S-1048	Adhesive
-4	Polyolefin, Flexible	RT-1304	/42;/86	S-1017;S-1048	Adhesive
-6	Silicone	RT-602	N/A		
-25	Elastomer, Fluid Resistant	RT-1325	N/A		

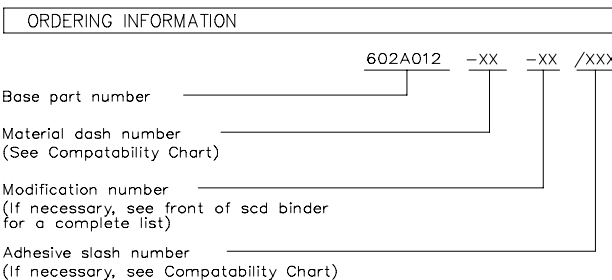

THIS DRAWING IS SUBJECT TO CHANGE WITHOUT NOTICE; CONSULT YOUR NEAREST FIELD REPRESENTATIVE FOR CURRENT REVISION

Raychem

RAYCHEM CORPORATION
300 CONSTITUTION DRIVE
MENLO PARK, CALIFORNIA 94025

Revision : D
Date : 2/12/97

Part Number : 602A012
Description : Transition, 1 To 5