

Evaluating the ADAU1962A/ADAU1966A High Performance, Low Power Multibit Sigma-Delta DAC

PACKAGE CONTENTS

ADAU1962A/ADAU1966A evaluation board
(EVAL-ADAU1962AZ/EVAL-ADAU1966AZ)

USBi control interface board

USB cable

12 V desktop supply

OTHER SUPPORTING DOCUMENTATION

ADAU1962A data sheet

ADAU1966A data sheet

EVALUATION BOARD OVERVIEW

This user guide describes the design and setup of the evaluation board for the ADAU1962A or the ADAU1966A. This document uses ADAU196xA to refer to either the ADAU1962A or the ADAU1966A. Since the ADAU1962A is a 12-channel part and the ADAU1966A is a 16-channel part, DAC outputs 13 through 16 do not function on the ADAU1962A evaluation board. The

evaluation board must be connected to an external 12 V dc power supply and ground. On-board regulators derive 5 V and 3.3 V supplies for the ADAU196xA and peripherals.

The ADAU196xA can be controlled through either an I²C or SPI interface. A small, external interface board, EVAL-ADUSB2EBZ, also called USBi, connects to a PC USB port and provides either I²C or SPI access to the evaluation board through a ribbon cable.

A graphical user interface (GUI) program, the Automated Register Window Builder, is provided for easy programming of the chip in a Windows® PC environment. The evaluation board allows demonstration and performance testing of most ADAU196xA features, including high performance DAC operation.

The board has an S/PDIF receiver with RCA and optical connectors, as well as a discrete serial audio interface. Analog outputs are accessible via eight stereo TRS mini jacks.

FUNCTIONAL BLOCK DIAGRAM

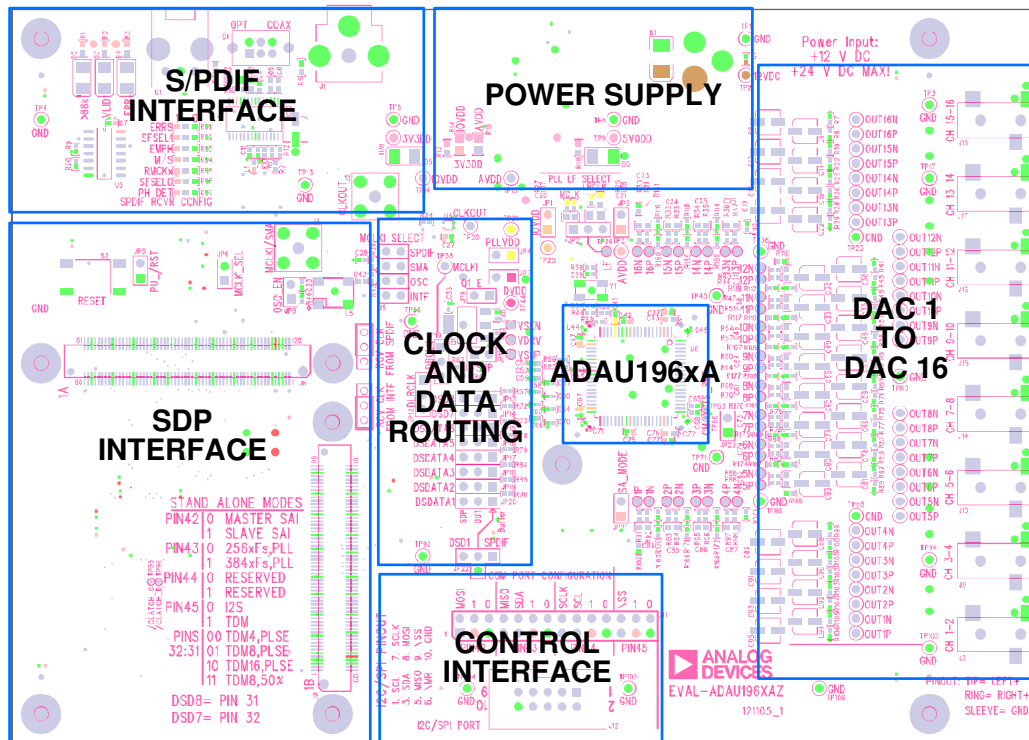

Figure 1.

TABLE OF CONTENTS

Package Contents.....	1	Powering the Board.....	5
Other Supporting Documentation.....	1	Resetting the Evaluation Board.....	5
Evaluation Board Overview.....	1	Setting Up the Master Clock (MCLK).....	6
Functional Block Diagram.....	1	Selecting PLL.....	6
Revision History.....	2	Routing Digital Audio Connections.....	7
Setting Up the Evaluation Board.....	3	Connecting Analog Audio Cables.....	8
Standalone Mode.....	3	Modification for Differential Output.....	8
I ² C and SPI Control.....	3	Modification to Use the N Output.....	8
Automated Register Window Builder Software Installation ..	4	Schematics and Artwork.....	9
Hardware Setup—USBi.....	4	Bill of Material.....	25

REVISION HISTORY

7/13—Revision 0: Initial Version

SETTING UP THE EVALUATION BOARD

STANDALONE MODE

The ADAU196xA has a standalone mode, which allows the user to choose between a limited number of operation modes without the need for a control interface. Applying a jumper across JP21, as shown in Figure 2, pulls SA_MODE (Pin 46) high enabling standalone mode in the ADAU196xA. The SA_MODE selections are listed in Table 1.

Table 1. Standalone Modes

Pin	Setting	Description
Pin 42	0	Master serial audio interface
	1	Slave serial audio interface
Pin 43	0	$256 \times f_s$
	1	$384 \times f_s$
Pin 44	0	Reserved, set to 0
Pin 45	0	I ² S mode
	1	TDM mode
Pin 32 to Pin 31	00	TDM4, pulse
	01	TDM8, pulse
	10	TDM16, pulse
	11	TDM8, 50% duty

On the EVAL-ADAU196xAZ, each of the four control port pins of the ADAU196xA are brought out to a block of jumpers, allowing the user to assign each pin to either the I²C or SPI ports. In standalone mode, these jumpers can connect the individual pins to high (IOVDD) or low (GND) to put the ADAU196xA in the desired mode.

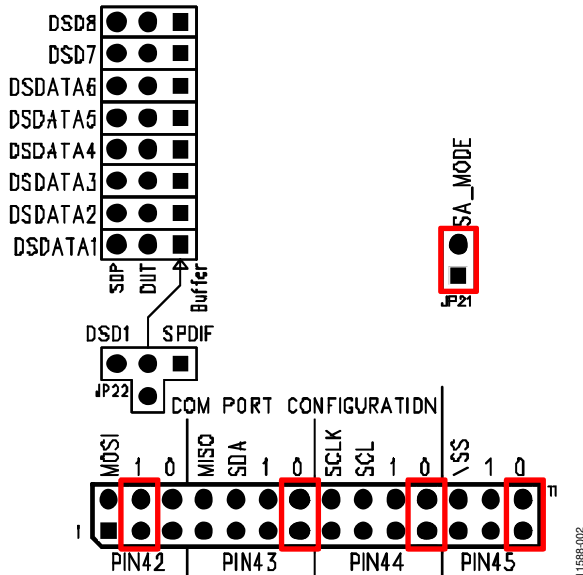

Figure 2. SA_MODE—Slave, $256 \times f_s$, I²S

The EVAL-ADAU196xAZ arrives configured for S/PDIF input. The S/PDIF receiver operates as a clock master, putting out an I²S stream at $256 \times f_s$. For quick startup, the ADAU196xA is in standalone mode with the settings shown in Figure 2.

Pin 42 is pulled high (1) and Pin 43 to Pin 45 are pulled low (0). According to Table 1, this puts the ADAU196xA in slave mode, running at $256 \times f_s$, and the audio serial port in I²S mode. Looking at Figure 2, notice that the jumper for Pin 42 is beneath the label for 1 and the other pins are assigned to 0.

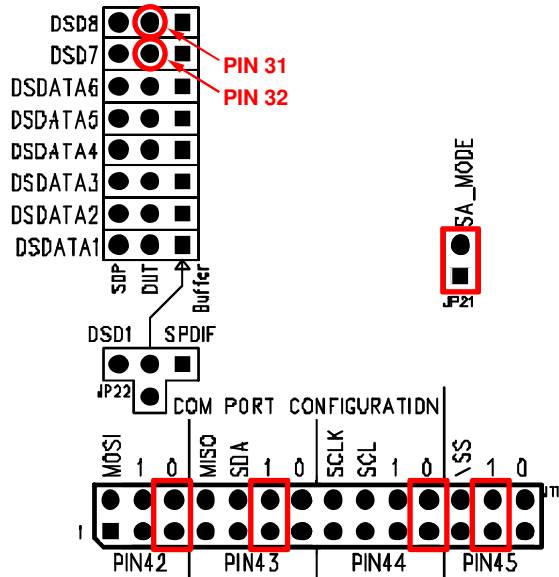

Figure 3. SA_MODE—Master, $384 \times f_s$, TDM

Figure 3 shows the other options for each SA_MODE configuration pin; master mode, running at $384 \times f_s$, and the audio serial port in TDM mode. In the case where the ADAU196xA is put in TDM mode, Pin 31 and Pin 32 can be pulled high (IOVDD) or low (GND) to achieve the modes listed in Table 1. The correct pins are located in the top left corner of Figure 3.

I²C AND SPI CONTROL

The evaluation board can be configured for live control over the registers in the ADAU196xA. When the Automated Register Window Builder software is installed and the USBi control interface is plugged into the board, the software can control the ADAU196xA. For this configuration, the ADAU196xA must be assigned to I²C mode using Address 00. See Figure 4 for the correct jumper positions.

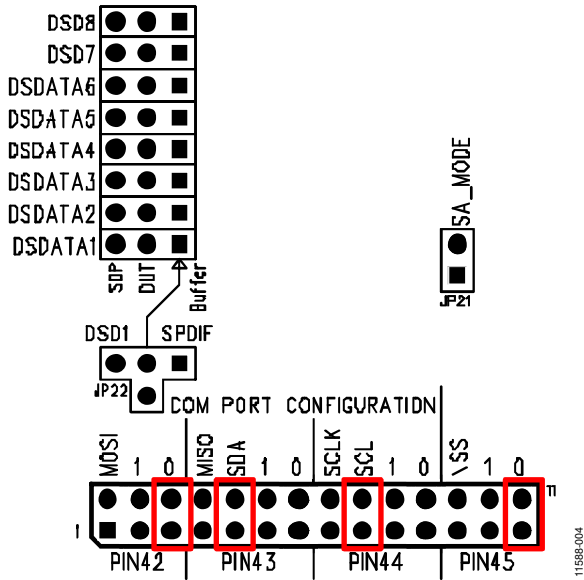

Figure 4. ADAU196xA I²C Control, Address 00

The Automated Register Window Builder controls the ADAU196xA and is available for download at www.analog.com/ADAU1962A or www.analog.com/ADAU1966A.

The ADAU196xA can also be put in SPI mode for control by other means. See Figure 5 for the correct jumper positions.

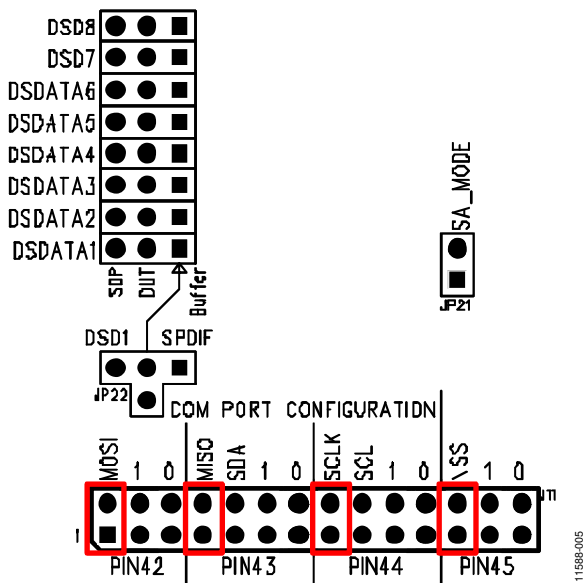

Figure 5. ADAU196xA SPI Control

AUTOMATED REGISTER WINDOW BUILDER SOFTWARE INSTALLATION

The Automated Register Window Builder is a program that launches a graphical interface for direct, live control of the ADAU196xA registers. The GUI content for a specific part is defined in a part-specific .xml file; these files are included in the software installation.

To install the Automated Register Window Builder software, follow these steps:

1. Go to www.analog.com/ADAU1962A or www.analog.com/ADAU1966A and download the ARWBvXX.zip file from the product page.
2. Open the downloaded ARWBvXX.zip file and extract the files to an empty folder on your PC.
3. Install the Automated Register Window Builder by double-clicking setup.exe and following the prompts. A computer restart is not required.
4. Copy the .xml file for the ADAU196xA from the extraction folder into the folder C:\ProgramFiles\Analog Devices Inc\AutomatedRegWin, if it is not already installed.

HARDWARE SETUP—USBi

To set up the USBi hardware, follow these steps:

1. Plug the USBi ribbon cable into the J12 I²C/SPI port.
2. Connect the USB cable to your computer and to the USBi.
3. When prompted for drivers,
 - a. Choose **Install from a list or a specific location**.
 - b. Choose **Search for the best driver in these locations**.
 - c. Check the box for **Include this location in the search**.
 - d. Find the USBi driver C:\Program Files\Analog Devices Inc\AutomatedRegWin\USB drivers.
 - e. Click **Next**.
 - f. If prompted to choose a driver, select **CyUSB.sys**.
 - g. If the PC is running Windows® XP and a message appears stating that the software has not passed Windows logo testing, click **Continue Anyway**.

You can now open the Automated Register Window Builder application and load the .xml file for the part on your evaluation board. Plug the 10-way ribbon cable on the USBi into the I²C/SPI port (J12) on the evaluation board.

POWERING THE BOARD

The EVAL-ADAU196xAZ evaluation board requires a power supply input of +12 V dc and ground to the power jack; +12 V draws ~150 mA at higher sample rates with all channels running.

The on-board regulators provide 5 V and 3.3 V rails. The 5 V rail is derived from +12 V by a switching regulator; it supplies 5 V for the 3.3 V power supply and other peripherals via the SDP interface optional resistors R133 and R156. The 3.3 V rail is derived from the 5 V supply by an LDO linear regulator; it provides voltage to AVDD and IOVDD as well as other active peripherals.

AVDD and IOVDD are connected on the board using 0R00 Ω 0805 package resistors. Should a need arise to insert a different power source, or measure current draw of the entire board, it can be accomplished using these 0 Ω jumpers.

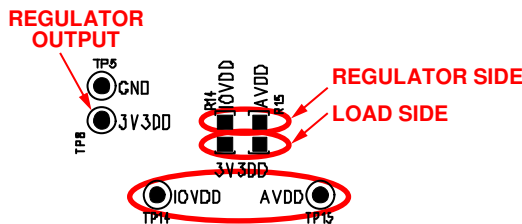

Figure 6. AVDD and IOVDD Jumper Resistors

The ADAU196xA has an internal voltage regulator that allows the user to derive DVDD and PLLVDD from the AVDD voltage source. The external PNP transistor Q1 and the passives, C36, C40, and R56, make the regulator circuit shown in Figure 7. Both JP9 and JP11 must be shorted to activate the circuit; JP9 supplies the emitter of the PNP and JP11 powers VSUPPLY (Pin 25) on the ADAU196xA.

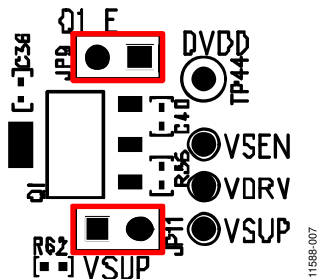

Figure 7. ADAU196xA Internal Regulator Jumpers

Links are provided along each ADAU196xA power rail to provide access for current measurement of only the ADAU196xA (see Figure 8). These links also allow the user to directly supply voltage from an outside source. The square pins and the test points are the load side. All four links must be connected for proper operation.

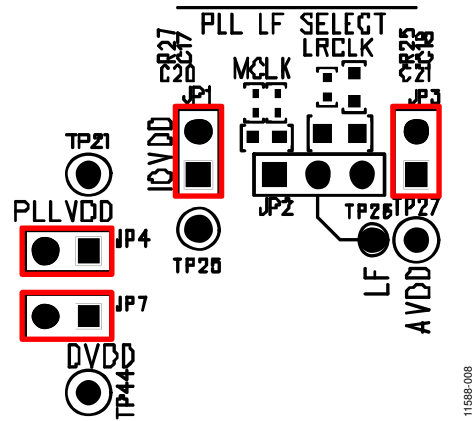

Figure 8. ADAU196xA Power Links

RESETTING THE EVALUATION BOARD

The EVAL-ADAU196xAZ has provisions for resetting and powering down the ADAU196xA. S2 on the evaluation board, shown in Figure 9, is a momentary reset switch that pulls the master reset (MR) line low; this line controls the reset generator U10. MR is also connected to the USBi and the SDP interface connectors through steering diodes and protection resistors so that outside devices can control the reset state of the evaluation board as shown in Figure 25. The power-down jumper JP5 allows the MR line to be tied low. The output of the reset generator drives the PU/RST line.

The PU/RST line is directly connected to two devices: the S/PDIF receiver and the ADAU196xA. The line is held low by a pull-down resistor until the reset generator U10 asserts the line high as shown in Figure 25. The PU/RST line is also connected to a pin on the SDP interface through a steering diode and protection resistor allowing external reset control.

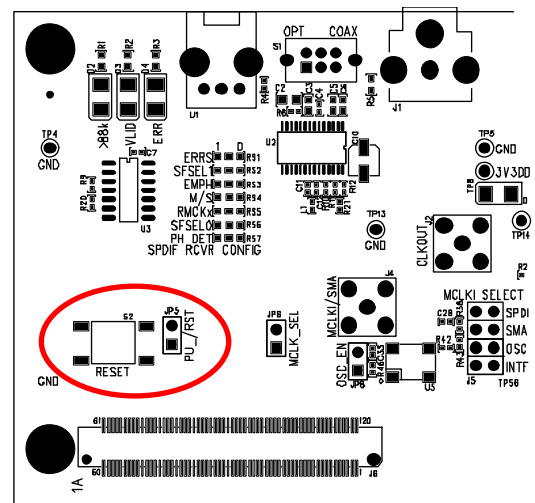

Figure 9. Reset Switch and Power-Down Jumper

SETTING UP THE MASTER CLOCK (MCLK)

The MCLK routing on the evaluation board is handled by a block of jumpers, J5, allowing any one of four sources to be selected—S/PDIF, the SMA connector, active OSC, and the INTF connector. The board arrives with S/PDIF selected as shown in Figure 10.

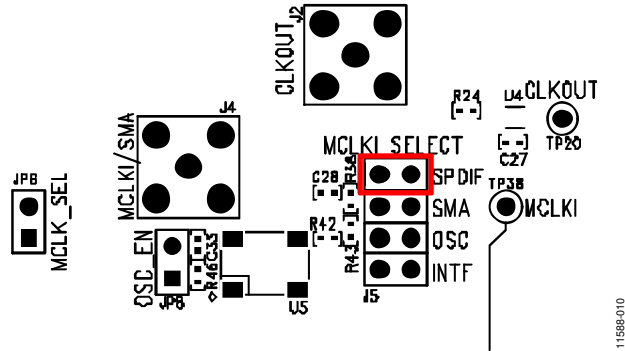

Figure 10. SPDIF Selected as MCLK Source

The evaluation board has a 12.288 MHz active oscillator that can be selected by shorting the OSC_EN jumper JP8 and selecting OSC on J5 as shown in Figure 11.

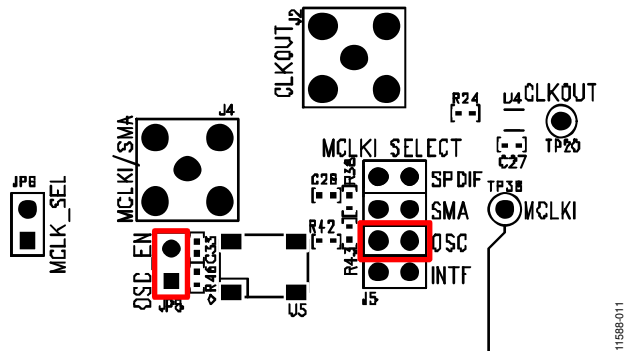

Figure 11. Active OSC Enabled and Selected as MCLK

The evaluation board can be set to receive MCLK from the SDP interface connectors. To do so, select the INTF setting on J5 and enable the MCLK buffer by shorting jumper J6, MCLK_SEL, as shown in Figure 12.

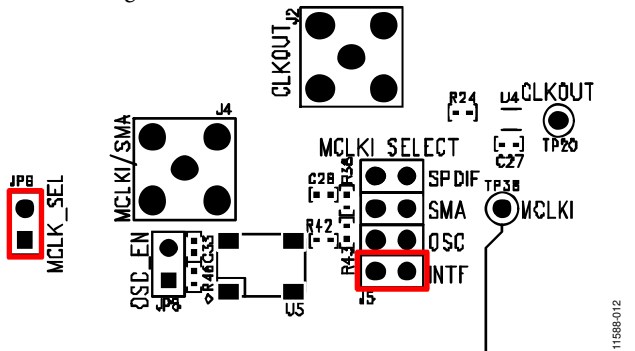

Figure 12. INTF Input Enabled and Selected

SELECTING PLL

The PLL in the ADAU196xA is very flexible, allowing the part to run from a wide range of either MCLK or LRCLK frequencies.

It is also possible to shut the PLL off altogether and use the part in direct lock mode; functionality with no PLL is limited to $256 \times f_s$.

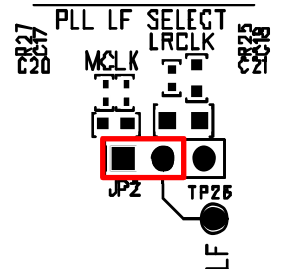

Figure 13. MCLK Selection for PLL Loop Filter

By default, the ADAU196xA runs from the PLL using MCLK as the clock source. The MCLK loop filter must be selected using JP2 as shown in Figure 13.

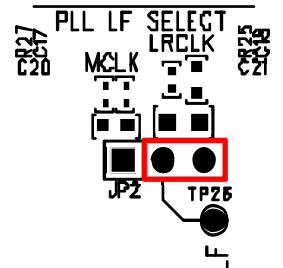

Figure 14. LRCLK Selection for PLL Loop Filter

DLRCLK can be selected as the PLL clock source using the PLL and Clock Control 0 Register [7:6]. In this case, the LRCLK loop filter must be selected as shown in Figure 14. If DLRCLK is selected as the PLL clock, there is no need for an MCLK.

ROUTING DIGITAL AUDIO CONNECTIONS

The ADAU196xA evaluation board has two separate inputs for digital audio signals: the S/PDIF and the SDP interface.

The S/PDIF receiver can handle either of two options: S/PDIF uses the RCA jack, J1, and optical uses the Toslink jack, U1. The input is selected using S1 as shown in Figure 15.

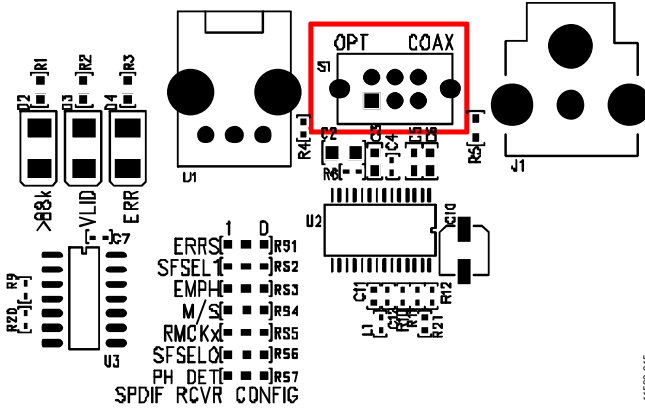

Figure 15. S/PDIF Input Selector Switch SW1

A series of resistors have been provided to set the functional mode of the S/PDIF receiver as shown in Figure 16. By default, the S/PDIF receiver runs in master mode, 256 × fs, I²S format. Consult the data sheet for the S/PDIF receiver to make the required changes to the hardware mode.

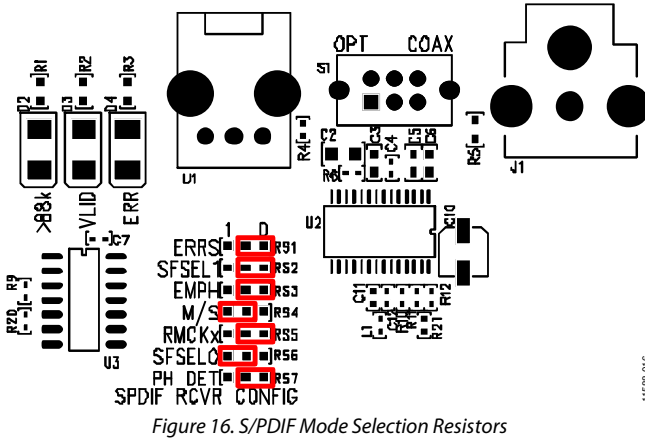

Figure 16. S/PDIF Mode Selection Resistors

The jumpers shown in Figure 17 are set for the S/PDIF receiver to drive the DBCLK and DLCLK clock ports and the eight DSDATAx lines of the ADAU1962A/ADAU1966A. JP22 selects the input to a buffer; the output of this buffer shows up on the right-hand column of JP13 to JP20.

The pins in the middle column of these jumpers are connected to the DSDATAx pins of the ADAU196xA through the appropriate line termination. DBCLK and DLCLK selections are made with JP10 and JP12 where the middle pins are connected to the DBCLK and DLCLK pins of the ADAU196xA.

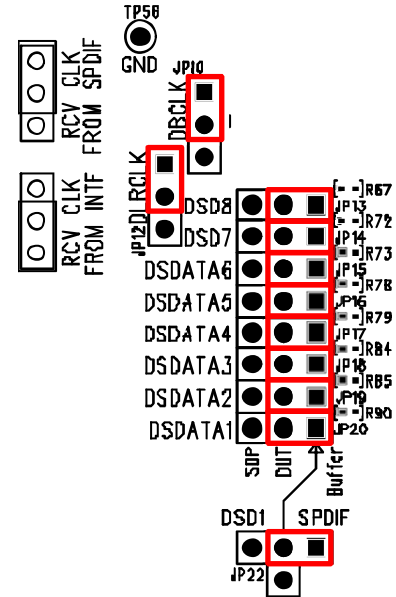

Figure 17. S/PDIF Data and Clock Routing

The system development platform (SDP) interfaces, J6 and J8, make up a standard interconnect within Analog Devices, Inc. They provide for the transfer of digital audio clocks and control between boards. See the pinout included in the schematic in Figure 27.

Figure 18 shows the jumper configuration for using the SDP interface connector as the digital audio source. JP22 is set so that the DSDATA1 source from the SDP interface is driving the buffer, and this buffer is connected to all eight DSDATA inputs of the ADAU196xA. JP10 and JP12 are set for the ADAU196xA to run in slave mode from clocks supplied by the SDP interface.

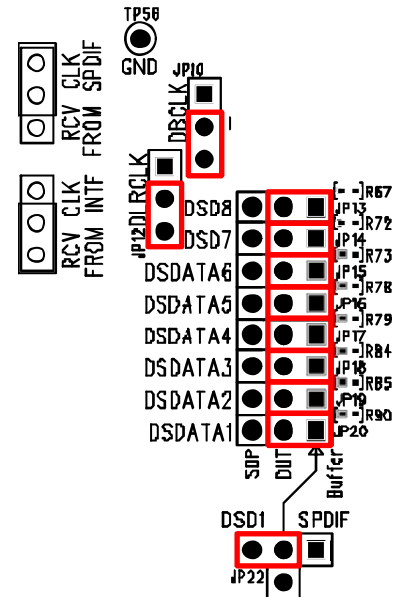

Figure 18. SDP Interface DSDATA1 Distribution

CONNECTING ANALOG AUDIO CABLES

There are two forms of the analog outputs of the ADAU196xA evaluation board: differential and single ended.

The board comes standard with the single-ended outputs appearing on through-hole test points as well as on the TRS mini connectors.

The single-ended outputs of the ADAU196xA drive the connectors directly, through a simple 1-pole RC filter with appropriate ac coupling.

To evaluate the differential outputs, one can modify the board to accomplish this with a little soldering and a few parts.

MODIFICATION FOR DIFFERENTIAL OUTPUT

The ADAU196xA evaluation board can be modified to be used differentially.

See Figure 19 for the schematic of the standard filter. To modify for balanced operation, perform the following steps for each channel:

1. Remove R6 (0 Ω jumper).
2. Change R1 from 470 Ω to 237 Ω (0402).
3. Add R2 (237 Ω , 0402).
4. Add C3 (10 μf).
5. Add R4 (49.9 k Ω , 0402).

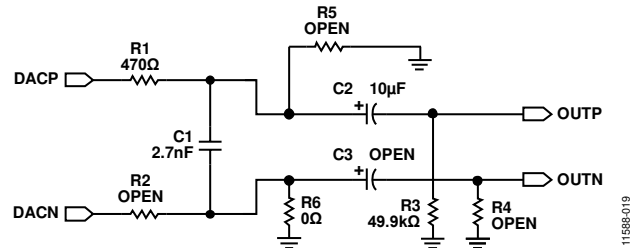

Figure 19. Typical Evaluation Board Filter

MODIFICATION TO USE THE N OUTPUT

The ADAU196xA evaluation board can be modified to use the DACN output instead of the DACP output. Should you need to invert all the channels, it is recommended to do so in the software using the DAC CONTROL 2 Register or by inverting the I²S data stream.

See Figure 19 for the schematic of the standard filter. To modify to use the N output, perform the following steps for each channel:

1. Move R6 over to R5 (0 Ω jumper).
2. Move R1 over to R2 (470 Ω).
3. Move C2 over to C3 (10 μF).
4. Move R3 over to R4 (49.9 k Ω).
5. Install a jumper between the N and P output test points.

Note that if new parts are to be used for R2, R4, R5, and C3, then R1, R3, R6, and C2 must be removed.

SCHEMATICS AND ARTWORK

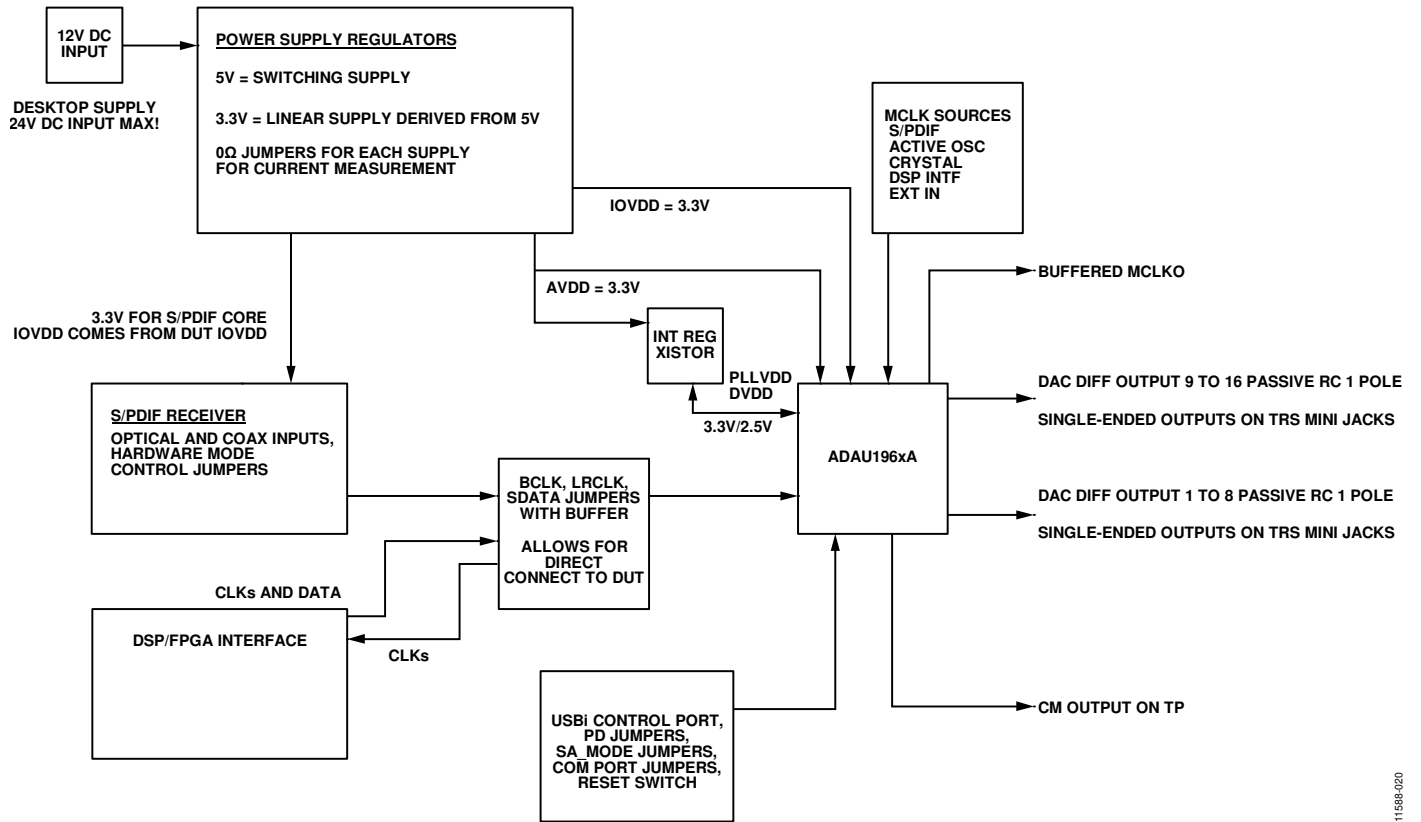

Figure 20. Schematic, Page 1—EVAL-ADAU196xAZ Block Diagram

11688-020

11588-022

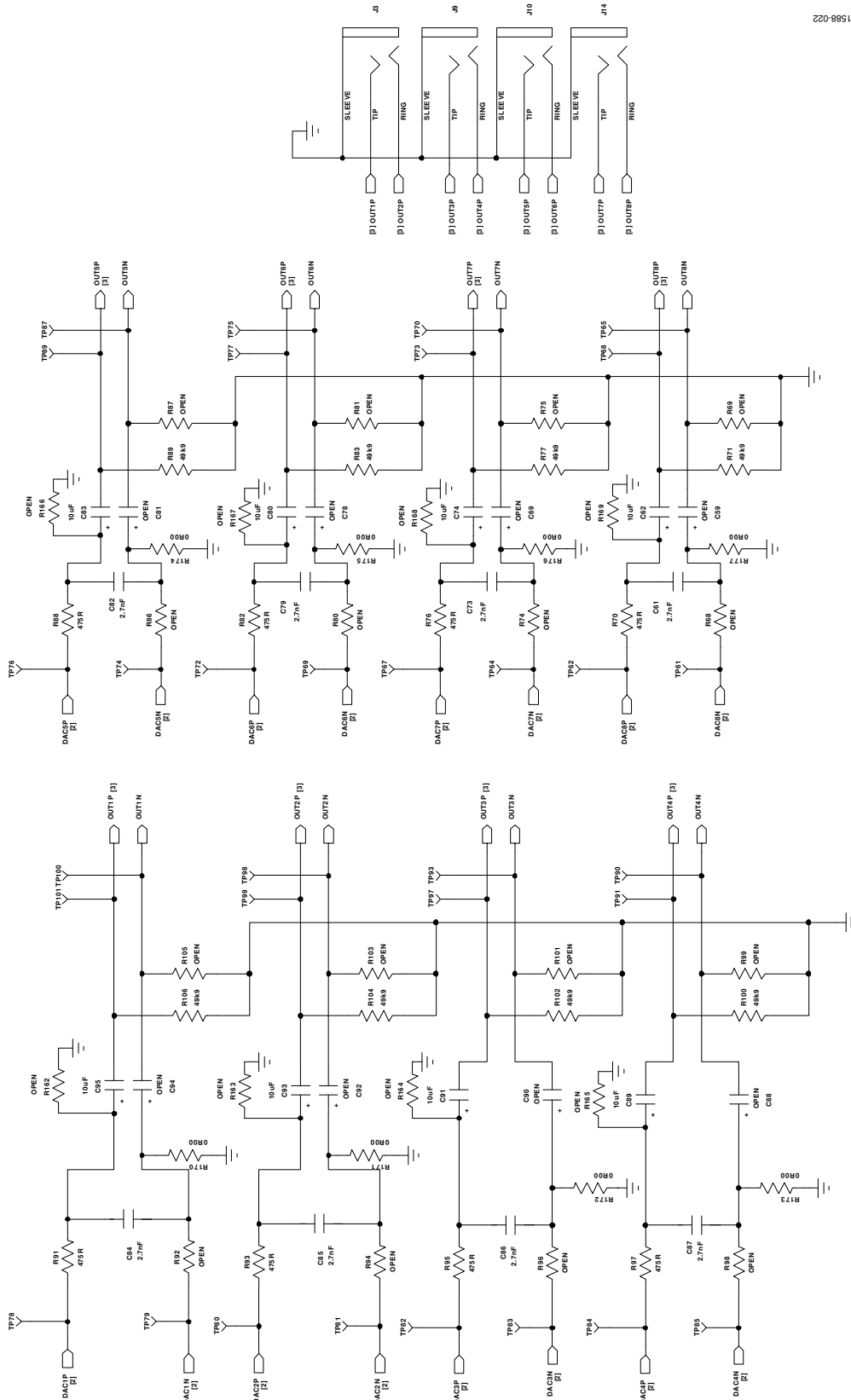

Figure 22. Schematic, Page 3—ADAU196xA DAC Output 1 to Output 8

11598-023

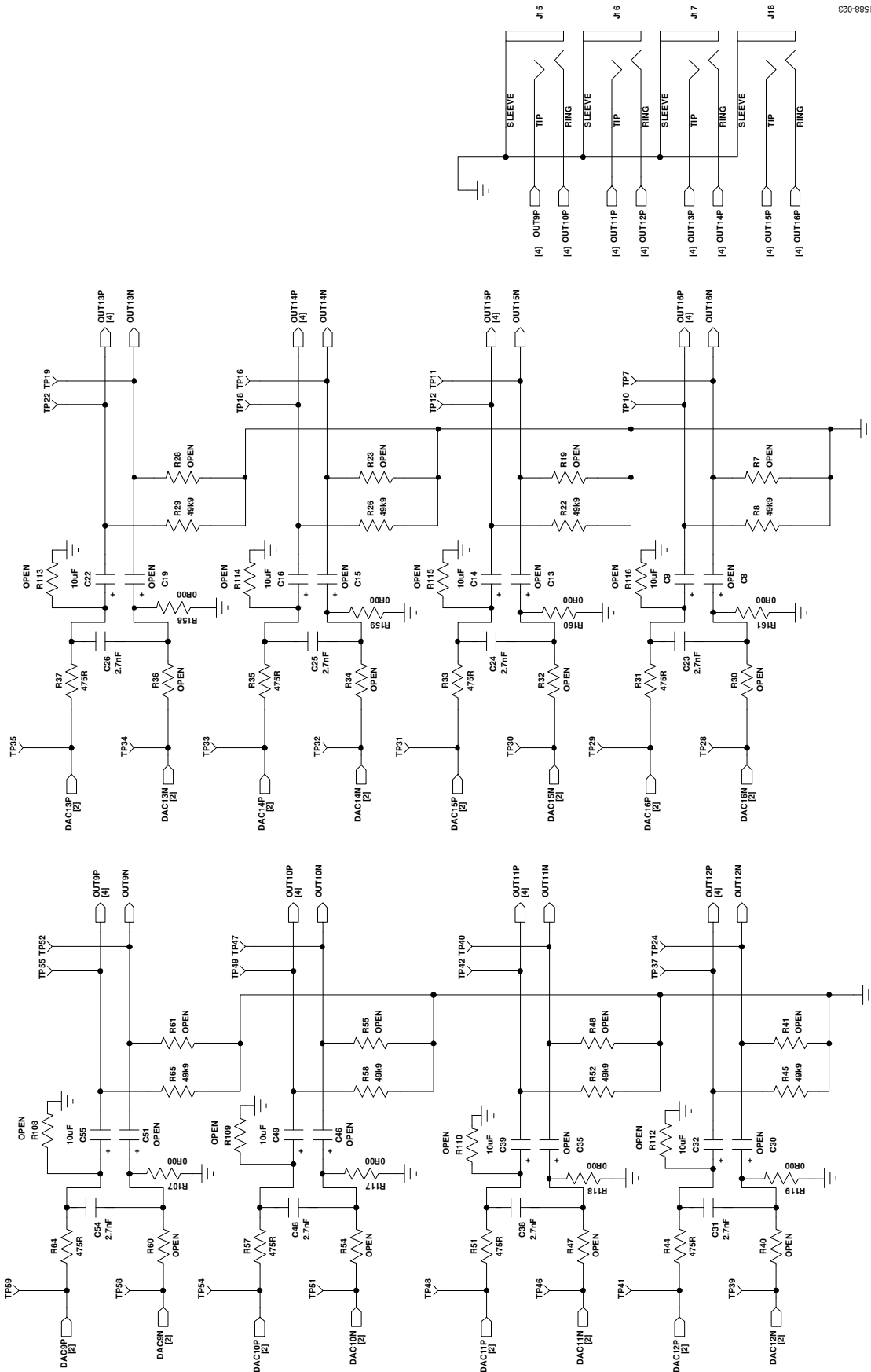

Figure 23. Schematic, Page 4—ADAU196xA DAC Output 9 to Output 12

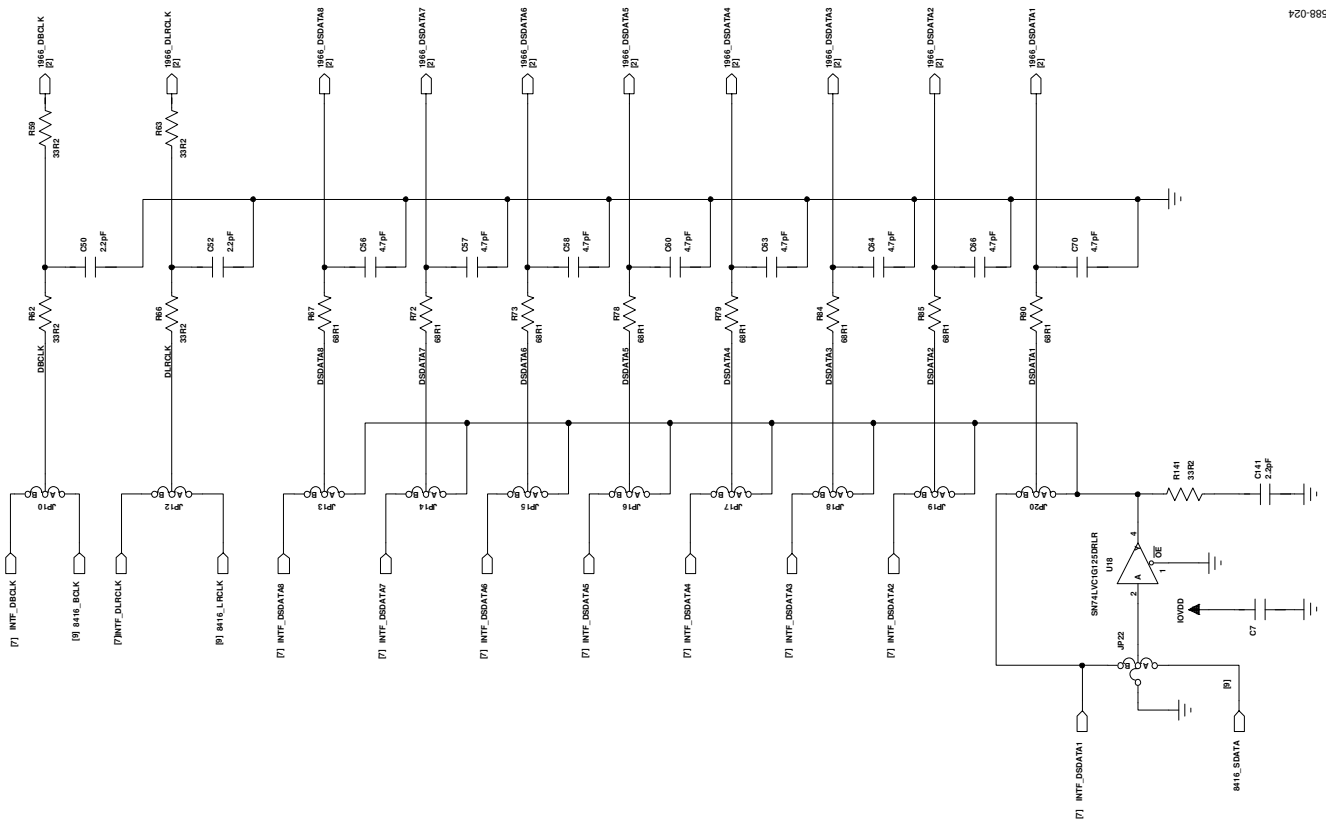

Figure 24. Schematic, Page 5—BCLK, LRCLK, and SDATA Jumpers and Routing

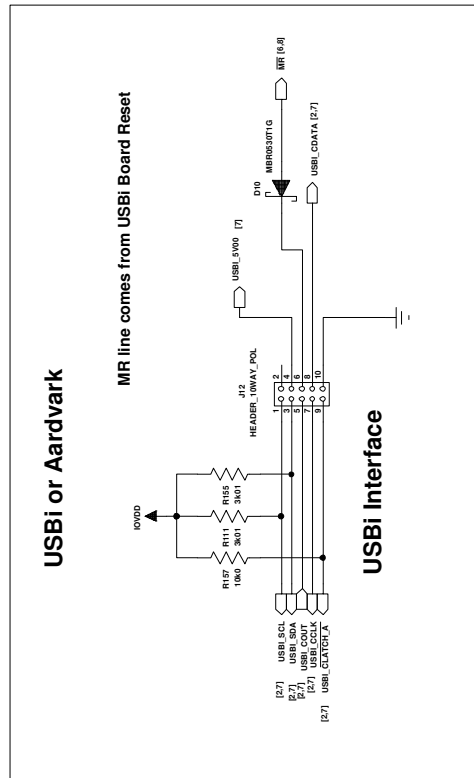
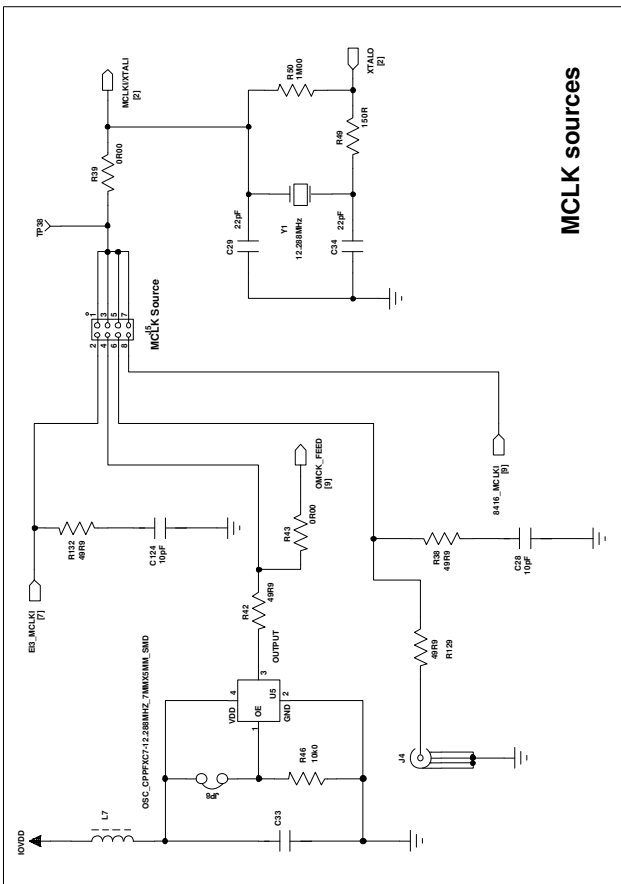
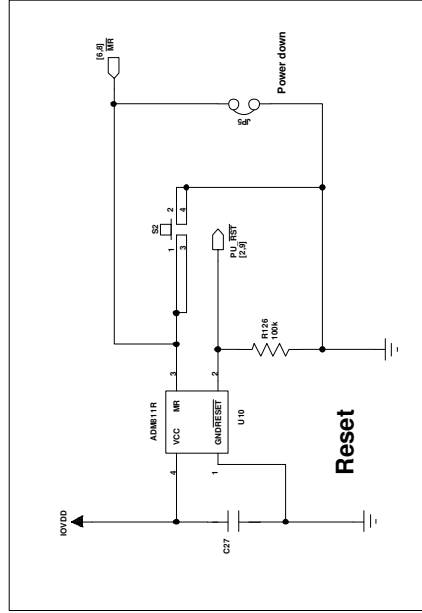
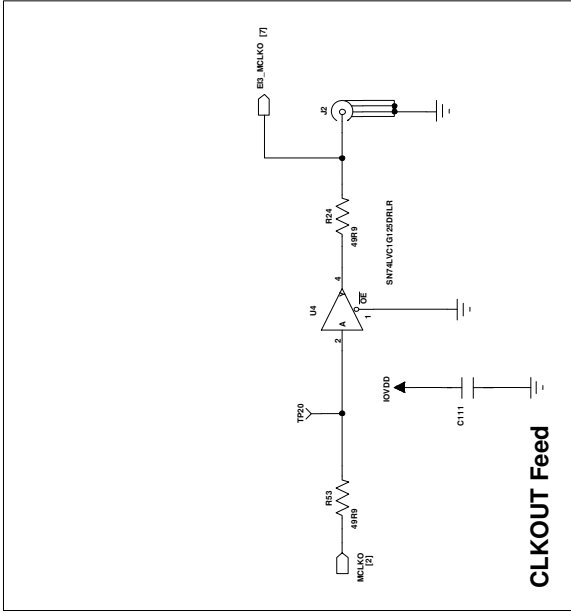

Figure 25. Schematic, Page 6—MCLK Selection, USBi Interface, CLKOUT Feed, and Reset Generator

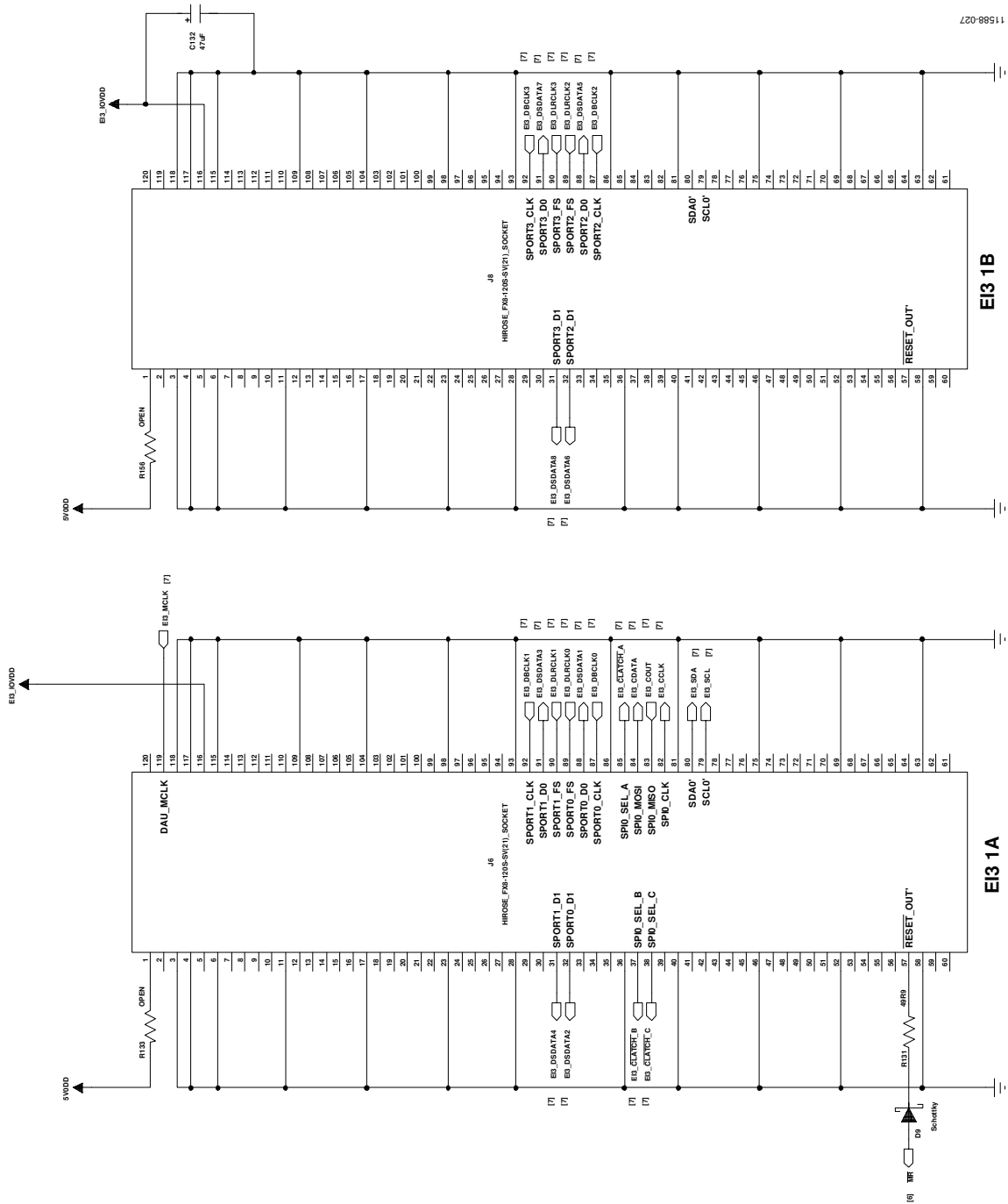
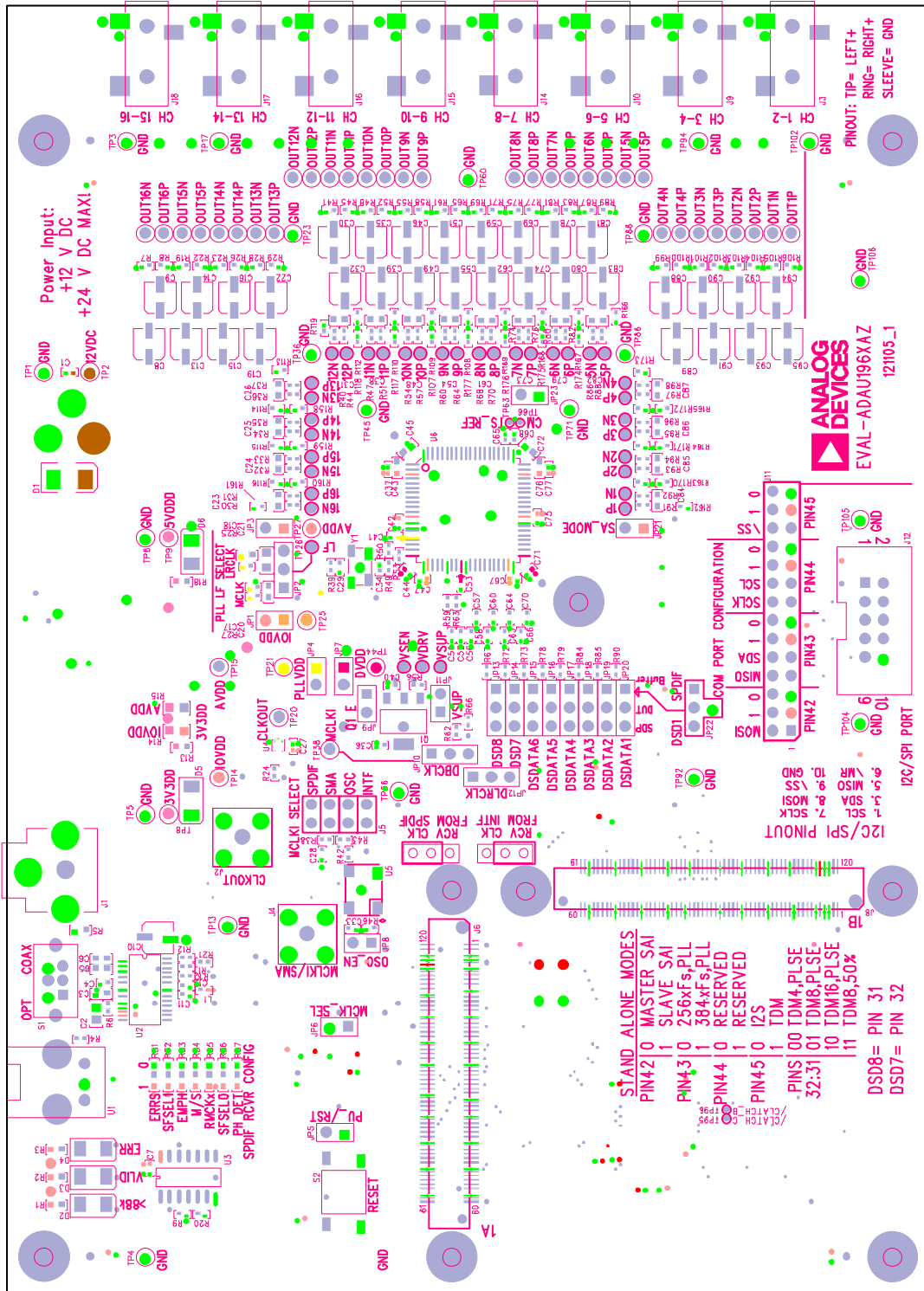
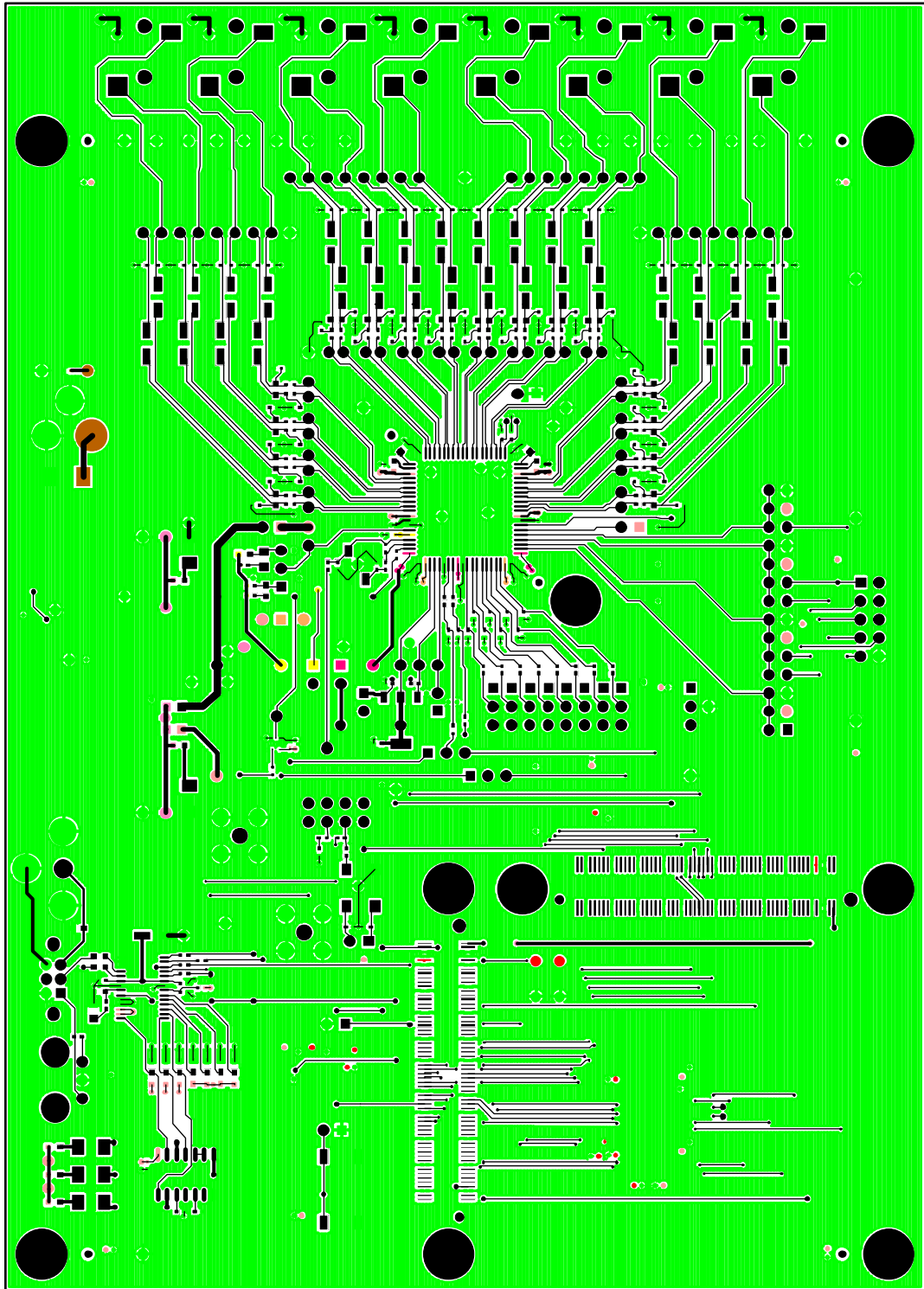

Figure 27. Schematic, Page 8—SDP Interface Connectors





11588-031

Figure 31. Top Layer Copper

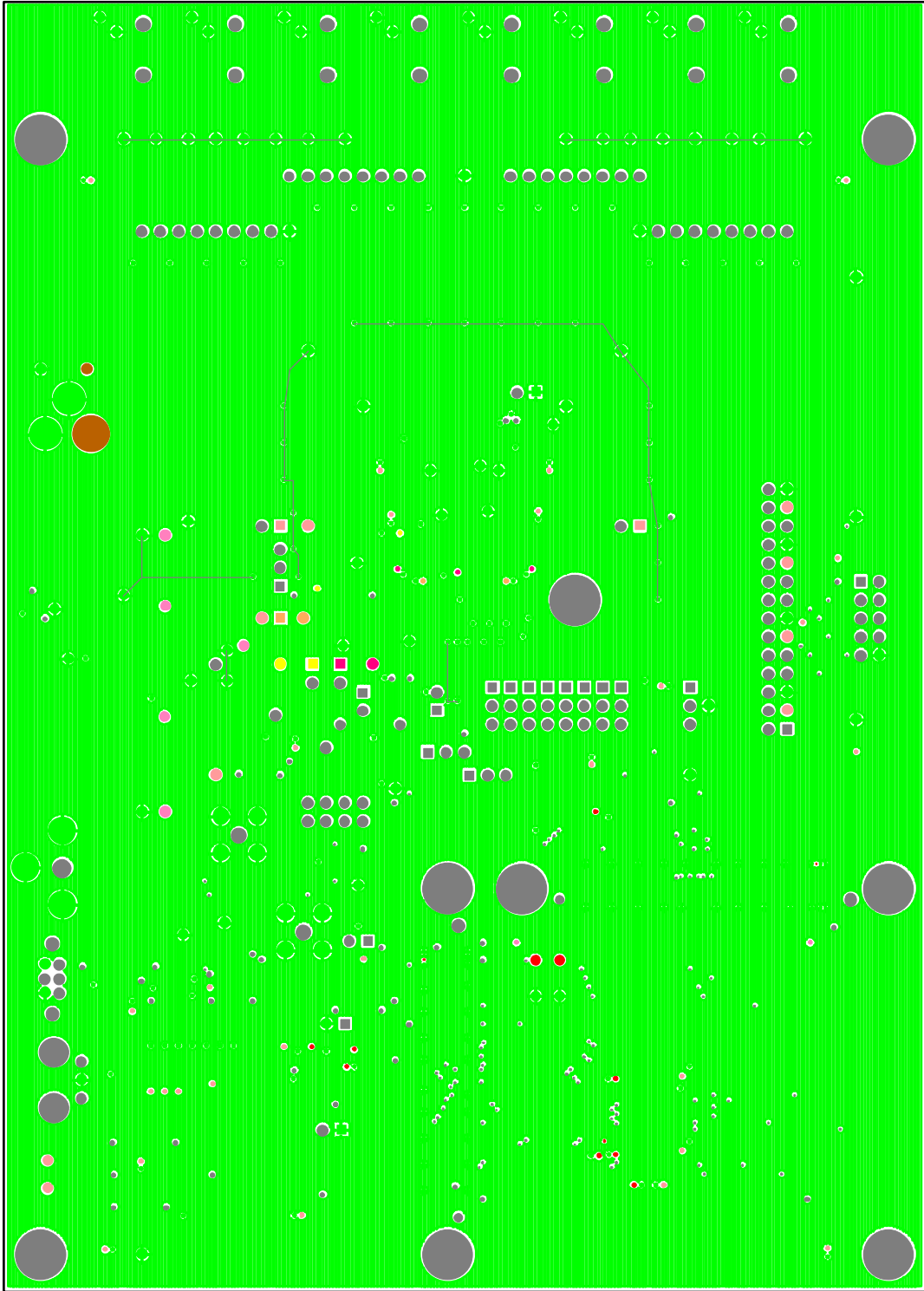

Figure 32. L2 Ground

11588-032

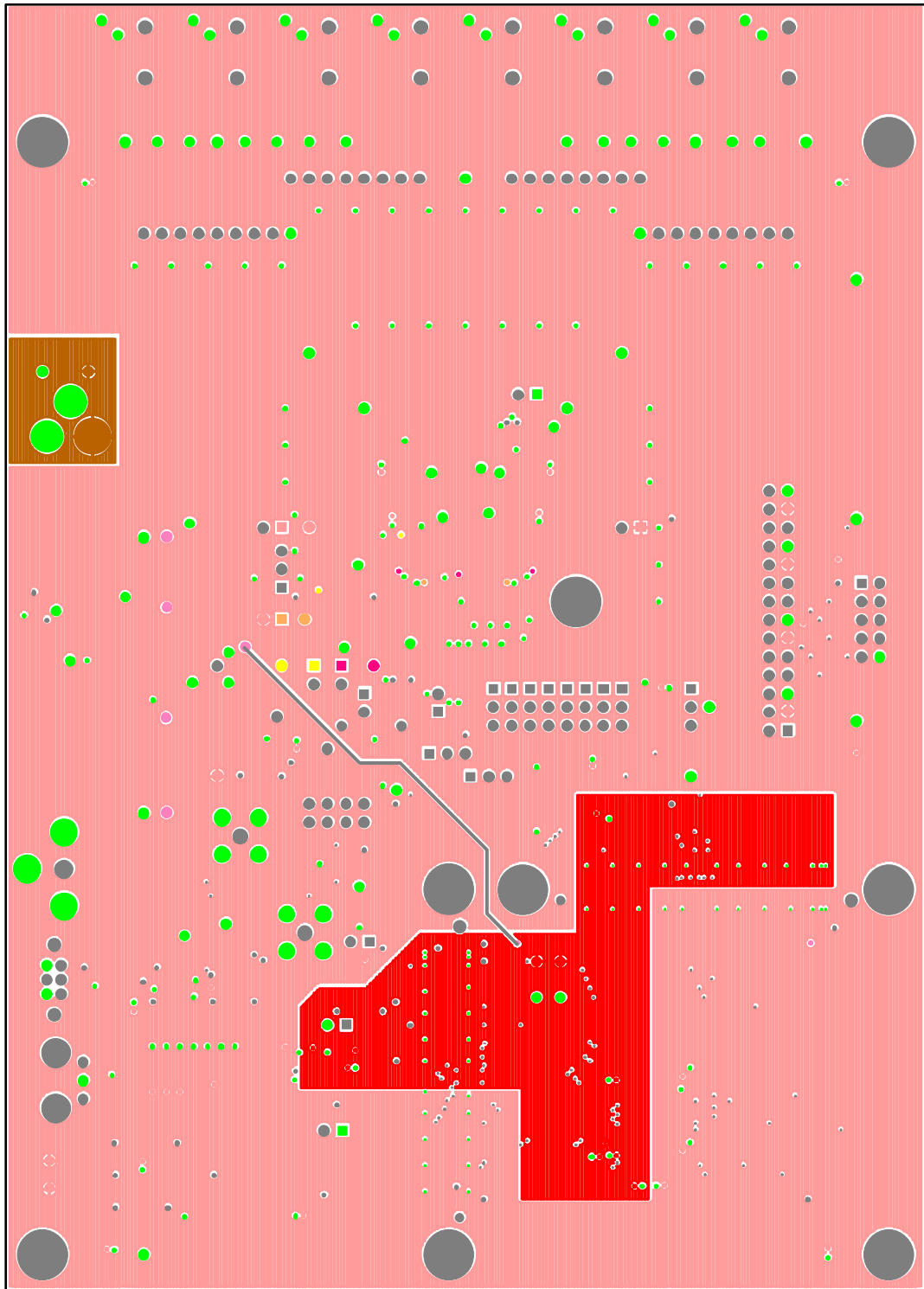

Figure 33. L3 Power

11568-033

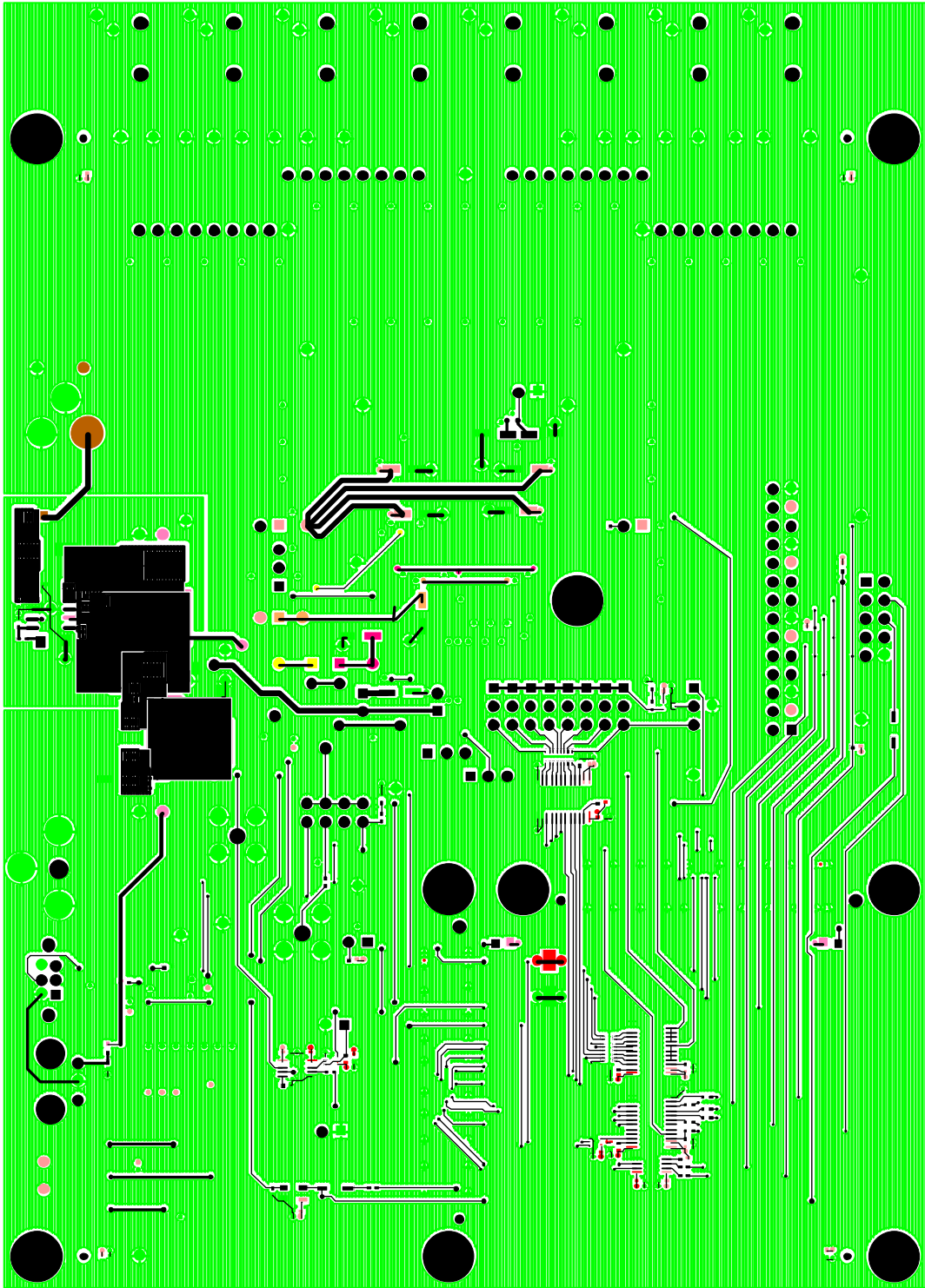

Figure 34. Bottom Copper

11968-034

BILL OF MATERIAL

Table 2.

Qty	Reference	Description	Manufacturer	Part Number	Vendor	Vendor Order #
1	U6	Multibit Sigma-Delta DAC	Analog Devices	ADAU1962AWBSTZ or ADAU1966AWBSTZ	Analog Devices	ADAU1962AWBSTZ or ADAU1966AWBSTZ
1	J12	10-way shroud, polarized header	3M	N2510-6002RB	Digi-Key	MHC10K-ND
1	U5	12.288 MHz, fixed SMD oscillator, 3.3 V to 5 V dc	Cardinal Components	CPPFX C 7 L T-A7 BR-12.288MHz TS	Cardinal Components	CPPFX C 7 L T-A7 BR-12.288MHz TS
2	J6, J8	120-pin socket, 0.6 mm	Hirose Electric	FX8-120S-SV(21)	Digi-Key	H1219-ND
1	U1	15 Mbps fiber optic receiving module with shutter	Toshiba	TORX147L(FT)	Digi-Key	TORX147LFT-ND
1	U2	192 kHz dgtl rcvr, 28-TSSOP	Cirrus Logic	CS8416-CZZ	Digi-Key	598-1124-5-ND
10	JP1, JP3 to JP9, JP11, JP21	2-pin header, unshrouded, jumper .0.10"; use Tyco 881545-2 shunt	Sullins Electronics Corp	PBC02SAAN or cut down PBC36SAAN	Digi-Key	S1011E-02-ND
1	U8	200 kHz, 1A, buck regulator	Analog Devices	ADP3050ARZ	Digi-Key	ADP3050ARZ-R7CT-ND
1	J11	28-way, unshrouded	3M	PBC14DAAN, or cut down PBC36DAAN	Digi-Key	S2011E-14-ND
1	U9	3-term adj voltage regulator DPAK	ST Microelectronics	LM317MDT-TR	Digi-Key	497-1574-1-ND
11	JP2, JP10, JP12 to JP20	3-pos SIP header	Sullins	PBC03SAAN or cut down PBC36SAAN	Digi-Key	S1011E-03-ND
1	JP22	3-pos T-header	Sullins	PBC03SAAN or cut down PBC36SAAN	Digi-Key	S1011E-03-ND plus single pin
1	J5	8-way, unshrouded, header dual row	Sullins Electronics Corp	PBC04DAAN or cut down PBC36DAAN	Digi-Key	S2011E-04-ND or cut down S2011E-36-ND
27	C9 to C10, C14, C16, C22, C32, C39, C49, C55, C62, C74, C80, C83, C89, C91, C93, C95, C11, C125 to C131, C133 to C134	Alum electrolytic capacitor, FC 105°, SMD_B, 10 µF	Panasonic EC	EEE-FC1C100R	Digi-Key	PCE3995CT-ND
4	C107, C118 to C119, C132	Alum electrolytic capacitor, FC 105°, 47 µF, SMD_D	Panasonic EC	EEE-FC1C470P	Digi-Key	PCE4000CT-ND
3	U4, U14, U18	Buffer 3-state, single gate	Texas Instruments	SN74LVC1G125DRLR	Digi-Key	296-18012-1-ND
1	Y1	Crystal, 12.288 MHz, SMT, 18 pF	Abracon Corp	ABM3B-12.288MHZ-10-1-U-T	Digi-Key	300-8198-1-ND
4	L1, L3 to L4, L7	Chip ferrite bead, 600 Ω @ 100 MHz	TDK Corp	MMZ1005S601C	Digi-Key	445-2162-1-ND
2	L2, L5	Chip ferrite bead, 600 Ω @ 100 MHz	Steward	HZ0805E601R-10	Digi-Key	240-2399-1-ND
3	R1 to R3	Chip resistor, 1%, 100 mW, thick film, 0603, 392R	Rohm	MCR03EZPFX3920	Digi-Key	RHM392HCT-ND
1	R5	Chip resistor, 1%, 100 mW thick film, 0603, 75R0	Panasonic EC	ERJ-3EKF75R0V	Digi-Key	P75.0HCT-ND

Qty	Reference	Description	Manufacturer	Part Number	Vendor	Vendor Order #
2	R13, R18	Chip resistor, 1%, 475R, 125 mW, thick film, 0603	Panasonic EC	ERJ-3EKF4750V	Digi-Key	P475HCT-ND
7	RS1 to RS7	Chip resistor, 1%, 47k5, 125 mW, thick film, 0603	Panasonic EC	ERJ-3EKF4752V	Digi-Key	P47.5KHCT-ND
1	R126	Chip resistor, 100k, 1%, 63 mW, thick film, 0402	Rohm	MCR01MZPF1003	Digi-Key	RHM100KLCT-ND
14	R4, R9, R20, R46, R127, R130, R134, R137 to R140, R144, R149, R157	Chip resistor, 1%, 10k0, 63 mW, thick film, 0402	Rohm	MCR01MZPF1002	Digi-Key	RHM10.0KLCT-ND
1	R121	Chip resistor, 1%, 10k2, 63 mW, thick film, 0402	Vishay/Dale	CRCW040210K2FKED	Digi-Key	541-10.2KLCT-ND
5	R10 to R12, R21, R49	Chip resistor, 1%, 150 R, 63 mW, thick film, 0402	Rohm	MCR01MZPF1500	Digi-Key	RHM150LCT-ND
1	R120	Chip resistor, 1%, 1k15, 63 mW, thick film, 0402	Panasonic EC	ERJ-2RKF1151X	Digi-Key	P1.15KLCT-ND
2	R56, R146	Chip resistor, 1%, 1k50, 63 mW, thick film, 0402	Panasonic EC	ERJ-2RKF1501X	Digi-Key	P1.50KLCT-ND
1	R50	Chip resistor, 1%, 1M00, 63 mW, thick film, 0402	Rohm	MCR01MZPF1004	Digi-Key	RHM1.00MLCT-ND
1	R124	Chip resistor, 1%, 243R, 63 mW, thick film, 0402	Vishay/Dale	CRCW0402243RFKED	Digi-Key	541-243LCT-ND
1	R122	Chip resistor, 1%, 32k4, 63 mW, thick film, 0402	Vishay/Dale	CRCW040232K4FKED	Digi-Key	541-32.4KLCT-ND
5	R59, R62 to R63, R66, R141	Chip resistor, 1%, 33R2, 63 mW, thick film, 0402	Panasonic EC	ERJ-2RKF33R2X	Digi-Key	P33.2LCT-ND
3	R6, R111, R155	Chip resistor, 1%, 3K01, 63 mW, thick film, 0402	Rohm	MCR01MZPF3011	Digi-Key	RHM3.01KLCT-ND
2	R25, R145	Chip resistor, 1%, 3k32, 63 mW, thick film, 0402	Vishay/Dale	CRCW04023K32FKED	Digi-Key	541-3.32KLCT-ND
1	R123	Chip resistor, 1%, 402R, 63 mW, thick film, 0402	Vishay/Dale	CRCW0402402RFKED	Digi-Key	541-402LCT-ND
16	R31, R33, R35, R37, R44, R51, R57, R64, R70, R76, R82, R88, R91, R93, R95, R97	Chip resistor, 1%, 475R, 63 mW, thick film, 0402	Stackpole	RMCF0402FT475R	Digi-Key	RMCF0402FT475RCT-ND
1	R125	Chip resistor, 1%, 47k5, 63 mW, thick film, 0402	Rohm	MCR01MZPF4752	Digi-Key	RHM47.5KLCT-ND
16	R8, R22, R26, R29, R45, R52, R58, R65, R71, R77, R83, R89, R100, R102, R104, R106	Chip resistor, 1%, 49k9, 63 mW, thick film, 0402	Vishay/Dale	CRCW040249K9FKED	Digi-Key	541-49.9KLCT-ND

Qty	Reference	Description	Manufacturer	Part Number	Vendor	Vendor Order #
15	R24, R38, R42, R53, R128 to R129, R131 to R132, R142 to R143, R147 to R148, R150 to R152	Chip resistor, 1%, 49R9, 63 mW, thick film, 0402	Rohm	MCR01MZPF49R9	Digi-Key	RHM49.9LCT-ND
1	R27	Chip resistor, 1%, 562R, 63 mW, thick film, 0402	Vishay/Dale	CRCW0402562RFKED	Digi-Key	541-562LCT-ND
8	R67, R72 to R73, R78 to R79, R84 to R85, R90	Chip resistor, 1%, 68R1, 63 mW, thick film, 0402	Rohm	MCR01MZPF68R1	Digi-Key	RHM68.1LCT-ND
18	R39, R43, R107, R117 to R119, R158 to R161, R170 to R177	Chip resistor, 5%, 0R00, 100 mW, thick film, 0402	Panasonic ECG	ERJ-2GE0R00X	Digi-Key	P0.0JCT-ND
2	R14 to R15	Chip resistor, 5%, 0R00, 125 mW, thick film, 0805	Panasonic EC	ERJ-6GEY0R00V	Digi-Key	P0.0ACT-ND
1	S1	DPDT slide switch vertical	E-Switch	EG2207	Digi-Key	EG1940-ND
48	R7, R19, R23, R28, R30, R32, R34, R36, R40 to R41, R47, to R48, R54 to R55, R60 to R61, R68 to R69, R74 to R75, R80 to R81, R86 to R87, R92, R94, R96, R98 to R99, R101, R103, R105, R108 to R110, R112 to R116, R162 to R169	Open	Open			
2	R133, R156	Open	Open			
32	TP7, TP10 to TP12, TP16, TP18 to TP19, TP22, TP24, TP37, TP40, TP42, TP47, TP49, TP52, TP55, TP65, TP68, TP70, TP73, TP75, TP77, TP87, TP89 to TP91, TP93, TP97 to TP101	Open	Open			
3	D3, D5 to D6	Green diffused, 10 millicandela, 565 nm 1206	Lumex Opto	SML-LX1206GW-TR	Digi-Key	67-1002-1-ND
1	U11	IC 2-bit, dual bus, TXRX 8-SSOP	Texas Instruments	SN74LVC2T45DCTR	DigiKey	296-16845-1-ND
3	U13, U16 to U17	IC 8-bit, dual bus, TXRX 24-SSOP	Texas Instruments	SN74LVCH8T245DBR	DigiKey	296-21067-1-ND
1	U15	IC I ² C bus, repeater 8-TSSOP	NXP Semiconductor	PCA9517DP-T	DigiKey	568-1829-2-ND
1	U3	IC inverter, hex TTL/LSTTL 14 SOIC	NXP Semiconductor	74HC04D-T	DigiKey	568-1384-1-ND
1	J13	Mini power jack, 0.08" R/A TH	Switchcraft, Inc.	RAPC722X	Digi-Key	SC1313-ND
32	TP1 to TP6, TP8 to TP9, TP13 to TP15, TP17, TP20 to TP21, TP23, TP25, TP27, TP36, TP38, TP44 to TP45, TP56, TP60, TP71, TP86, TP88, TP92, TP94, TP102, TP104 to TP106	Mini test point, white .1" OD	Keystone Electronics	5002	Digi-Key	5002K-ND

Qty	Reference	Description	Manufacturer	Part Number	Vendor	Vendor Order #
2	C113 to C114	Multilayer ceramic, 47 μ F, 10 V, X5R, 1206	Kemet	C1206C476M8PACTU	Digi-Key	399-5508-6-ND
44	C1, C4, C7, C11 to C12, C27, C33, C36 to C37, C40 to C42, C44, C47, C53, C65, C67 to C68, C71, C75, C77, C105, C108, C110 to C112, C116 to C117, C120 to C123, C135 to C140, C142 to C143, C145 to C146, C152, C154	Multilayer ceramic, 0.10 μ F, 16 V, X7R, 0402	Murata ENA	GRM155R71C104KA88D	Digi-Key	490-3261-1-ND
5	C43, C45, C72, C76, C109	Multilayer ceramic, 47 μ F, 16 V, X7R, 0603	Taiyo Yuden	EMK107B7474KA-T	Digi-Key	587-1250-1-ND
2	C5 to C6	Multilayer ceramic, 10 nF, 25 V, NP0, 0603	TDK Corp	C1608C0G1E103J	Digi-Key	445-2664-1-ND
1	C20	Multilayer ceramic, 5.6 nF, 25 V, NP0, 0603	TDK Corp	C1608C0G1E562J	Digi-Key	445-2666-1-ND
1	C2	Multilayer ceramic, 22 nF, 25 V, NP0, 0805	Murata ENA	GRM21B5C1H223JA01L	Digi-Key	490-1644-1-ND
2	C28, C124	Multilayer ceramic, 10 pF, 50 V, NP0, 0402	Kemet	C0402C100J5GACTU	Digi-Key	399-1011-1-ND
3	C50, C52, C141	Multilayer ceramic, 2.2 pF, 50 V, NP0, 0402	Johanson Technology	500R07S2R2BV4T	Digi-Key	712-1279-1-ND
2	C29, C34	Multilayer ceramic, 22 pF, 50 V, NP0, 0402	Murata ENC	GRM1555C1H220JZ01D	Digi-Key	490-1283-1-ND
2	C17, C104	Multilayer ceramic, 390 pF, 50 V, NP0, 0402	Murata ENA	GRM1555C1H391JA01D	Digi-Key	490-1296-1-ND
8	C56 to C58, C60, C63 to C64, C66, C70	Multilayer ceramic, 4.7 pF, 50 V, NP0, 0402	Johanson Technology	500R07S4R7BV4T	Digi-Key	12-1166-1-ND
1	C18	Multilayer ceramic, 2.2 nF, 50 V, NP0, 0603	Murata Electronics	GRM1885C1H222JA01D	Digi-Key	490-1459-1-ND
1	C3	Multilayer ceramic, 1.0 nF, 50 V, NP0, 0603	Panasonic EC	ECJ-1VC1H102J	Digi-Key	PCC2151CT-ND
16	C23 to C-26, C31, C38, C48, C54, C61, C73, C79, C82, C84 to C87	Multilayer ceramic, 2.7 nF, 50 V, NP0, 0603	Murata ENA	GRM1885C1H272JA01D	Mouser	81-GRM185C1H272JA01D
1	C106	Multilayer ceramic, 68 nF, 50 V, NP0, 1206	Murata	GCM31C5C1H683JA16L	Digi-Key	490-5323-1-ND
1	C21	Multilayer ceramic, 39 nF, 50 V, X7R, 0805	Panasonic EC	ECJ-2VB1H393K	Digi-Key	PCC1835CT-ND
16	C8, C13, C15, C19, C30, C35, C46, C51, C59, C69, C78, C81, C88, C90, C92, C94	10 μ F, not fitted	Panasonic EC	EEE-FC1C100R	Digi-Key	PCE3995CT-ND
1	JP23	2 jumper, not fitted	Sullins Electronics Corp	PBC02SAAN or cut down PBC36SAAN	Digi-Key	S1011E-02-ND

Qty	Reference	Description	Manufacturer	Part Number	Vendor	Vendor Order #
1	Q1	PNP transistor	Zetex, Inc.	ZX5T953GTA	Digi-Key	ZX5T953GCT-ND
1	J1	RCA jack, PCB TH mount, R/A yellow	Connect-Tech Products Corp.	CTP-021A-S-YEL	Connect-Tech	CTP-021A-S-YEL
1	D4	Red diffused, 6.0 millicandela, 635 nm 1206	Lumex Opto	SML-LX1206IW-TR	Digi-Key	67-1003-1-ND
2	R135 to R136	Resistor network, isolated 8 res, 33R0	CTS Corp.	741X163330JP	Digi-Key	741X163330JPCT-ND
2	J2, J4	SMA receptacle, straight PCB mount	Amp-RF Division	901-144-8RFX	Digi-Key	ARFX1231-ND
1	L6	SMT power inductor, 22 μ H	Coilcraft	MSS12778-223MLB	Coilcraft	MSS12778-223MLB
1	U12	Sngl bus, buff gate, 3ST SOP-5	Texas Instruments	SN74LVC1G126DRLR	DigiKey	296-18013-1-ND
1	D8	Schottky 30 V, 0.2 A, SOD123 diode	On Semiconductor	BAT54T1G	Digi-Key	BAT54T1GOSCT-ND
2	D9 to D10	Schottky 30 V, 0.5 A, SOD123 diode	On Semiconductor	MBR0530T1G	Digi-Key	MBR0530T1GOSCT-ND
1	D7	Schottky 40 V, 1 A, SOD123 diode	Diodes, Inc	1N5819HW-7-F	Digi-Key	1N5819HW-FDICT-ND
8	J3, J9 to J10, J14 to J18	Stereo mini jack SMT	CUI, Inc.	SJ-3523-SMT	Digi-Key	CP-3523SJCT-ND
1	D1	TVS Zener 15 V, 600 W SMB	ON Semiconductor	1SMB15AT3G	Digi-Key	1SMB15AT3GOSCT-ND
1	S2	Tact switch, 6 mm, gull wing, SPST-NO	Tyco/Alcoswitch	FSM6JSMA	Digi-Key	450-1133-ND
1	D2	Yellow diffused, 4.0 millicandela, 585 nm 1206	CML Innovative Tech	CMD15-21VYD/TR8	Digi-Key	L62307CT-ND
1	U10	Microprocessor voltage supervisor, logic low RESET output	Analog Devices	ADM811RARTZ-REEL7	Analog Devices	ADM811RARTZ-REEL7

NOTES

NOTES

NOTES

I²C refers to a communications protocol developed by Philips Semiconductors (now NXP Semiconductors).

**ESD Caution**

ESD (electrostatic discharge) sensitive device. Charged devices and circuit boards can discharge without detection. Although this product features patented or proprietary protection circuitry, damage may occur on devices subjected to high energy ESD. Therefore, proper ESD precautions should be taken to avoid performance degradation or loss of functionality.

Legal Terms and Conditions

By using the evaluation board discussed herein (together with any tools, components documentation or support materials, the "Evaluation Board"), you are agreeing to be bound by the terms and conditions set forth below ("Agreement") unless you have purchased the Evaluation Board, in which case the Analog Devices Standard Terms and Conditions of Sale shall govern. Do not use the Evaluation Board until you have read and agreed to the Agreement. Your use of the Evaluation Board shall signify your acceptance of the Agreement. This Agreement is made by and between you ("Customer") and Analog Devices, Inc. ("ADI"), with its principal place of business at One Technology Way, Norwood, MA 02062, USA. Subject to the terms and conditions of the Agreement, ADI hereby grants to Customer a free, limited, personal, temporary, non-exclusive, non-sublicensable, non-transferable license to use the Evaluation Board FOR EVALUATION PURPOSES ONLY. Customer understands and agrees that the Evaluation Board is provided for the sole and exclusive purpose referenced above, and agrees not to use the Evaluation Board for any other purpose. Furthermore, the license granted is expressly made subject to the following additional limitations: Customer shall not (i) rent, lease, display, sell, transfer, assign, sublicense, or distribute the Evaluation Board; and (ii) permit any Third Party to access the Evaluation Board. As used herein, the term "Third Party" includes any entity other than ADI, Customer, their employees, affiliates and in-house consultants. The Evaluation Board is NOT sold to Customer; all rights not expressly granted herein, including ownership of the Evaluation Board, are reserved by ADI. CONFIDENTIALITY. This Agreement and the Evaluation Board shall all be considered the confidential and proprietary information of ADI. Customer may not disclose or transfer any portion of the Evaluation Board to any other party for any reason. Upon discontinuation of use of the Evaluation Board or termination of this Agreement, Customer agrees to promptly return the Evaluation Board to ADI. ADDITIONAL RESTRICTIONS. Customer may not disassemble, decompile or reverse engineer chips on the Evaluation Board. Customer shall inform ADI of any occurred damages or any modifications or alterations it makes to the Evaluation Board, including but not limited to soldering or any other activity that affects the material content of the Evaluation Board. Modifications to the Evaluation Board must comply with applicable law, including but not limited to the RoHS Directive. TERMINATION. ADI may terminate this Agreement at any time upon giving written notice to Customer. Customer agrees to return to ADI the Evaluation Board at that time. LIMITATION OF LIABILITY. THE EVALUATION BOARD PROVIDED HEREUNDER IS PROVIDED "AS IS" AND ADI MAKES NO WARRANTIES OR REPRESENTATIONS OF ANY KIND WITH RESPECT TO IT. ADI SPECIFICALLY DISCLAIMS ANY REPRESENTATIONS, ENDORSEMENTS, GUARANTEES, OR WARRANTIES, EXPRESS OR IMPLIED, RELATED TO THE EVALUATION BOARD INCLUDING, BUT NOT LIMITED TO, THE IMPLIED WARRANTY OF MERCHANTABILITY, TITLE, FITNESS FOR A PARTICULAR PURPOSE OR NON-INFRINGEMENT OF INTELLECTUAL PROPERTY RIGHTS. IN NO EVENT WILL ADI AND ITS LICENSORS BE LIABLE FOR ANY INCIDENTAL, SPECIAL, INDIRECT, OR CONSEQUENTIAL DAMAGES RESULTING FROM CUSTOMER'S POSSESSION OR USE OF THE EVALUATION BOARD, INCLUDING BUT NOT LIMITED TO LOST PROFITS, DELAY COSTS, LABOR COSTS OR LOSS OF GOODWILL. ADI'S TOTAL LIABILITY FROM ANY AND ALL CAUSES SHALL BE LIMITED TO THE AMOUNT OF ONE HUNDRED US DOLLARS (\$100.00). EXPORT. Customer agrees that it will not directly or indirectly export the Evaluation Board to another country, and that it will comply with all applicable United States federal laws and regulations relating to exports. GOVERNING LAW. This Agreement shall be governed by and construed in accordance with the substantive laws of the Commonwealth of Massachusetts (excluding conflict of law rules). Any legal action regarding this Agreement will be heard in the state or federal courts having jurisdiction in Suffolk County, Massachusetts, and Customer hereby submits to the personal jurisdiction and venue of such courts. The United Nations Convention on Contracts for the International Sale of Goods shall not apply to this Agreement and is expressly disclaimed.