

THIS DRAWING IS UNPUBLISHED. RELEASED FOR PUBLICATION 2003
 © COPYRIGHT 2003 BY TYCO ELECTRONICS CORPORATION. ALL RIGHTS RESERVED.

REVISIONS					
P	LTR	DESCRIPTION	DATE	DWN	APVD
D2		PROD. SPEC INFO ADDED	01OCT2010	PKS	MP
D3		ECR-19-010275	02JUL2019	KD	FL
D4		ECR-20-001157	13APR2020	KD	FL

PERSPECTIVE VIEW FOR REF. ONLY SCALE 1:1

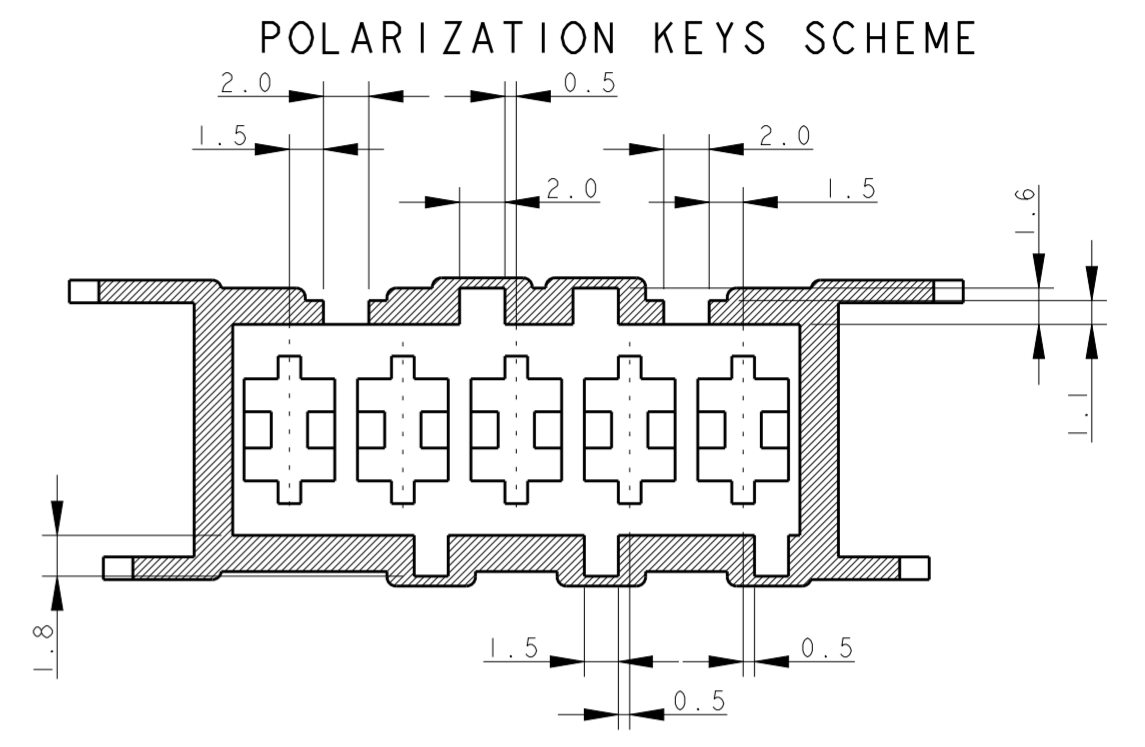
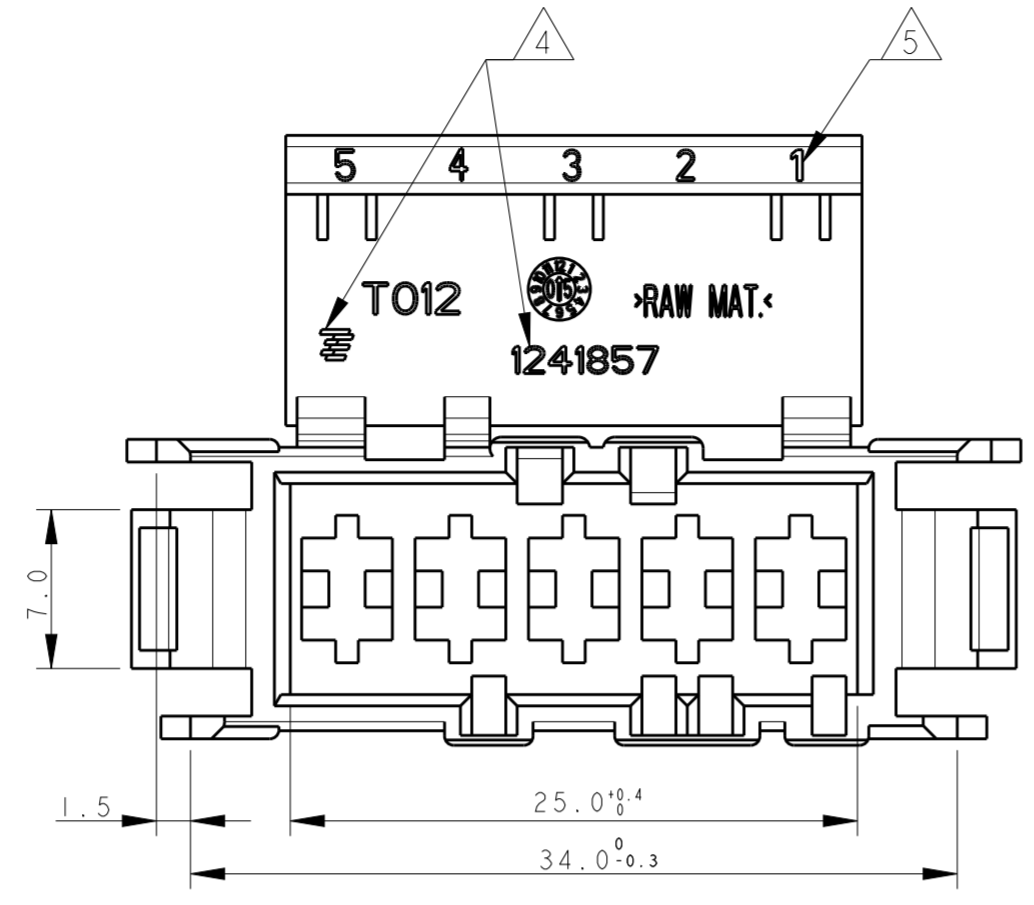
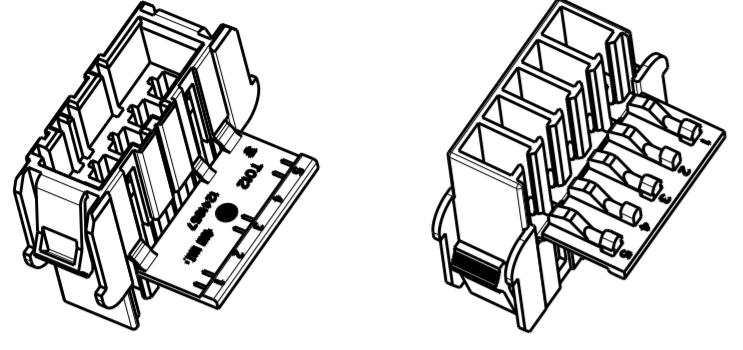

SECTION D-D

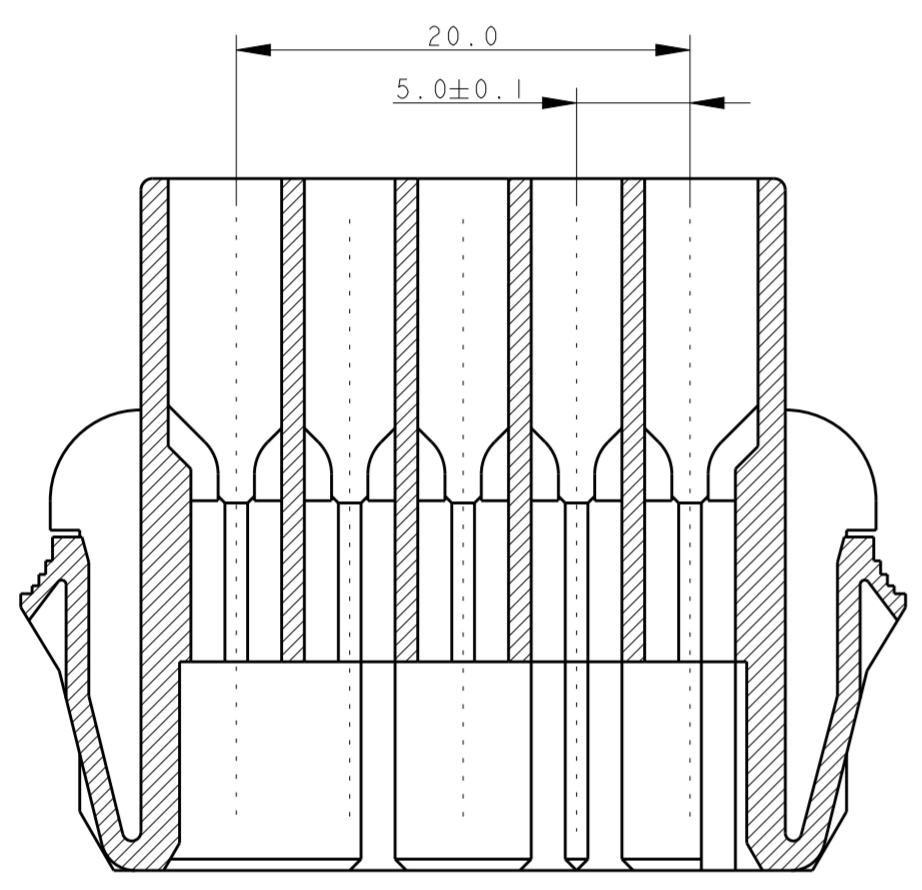

SECTION A-A

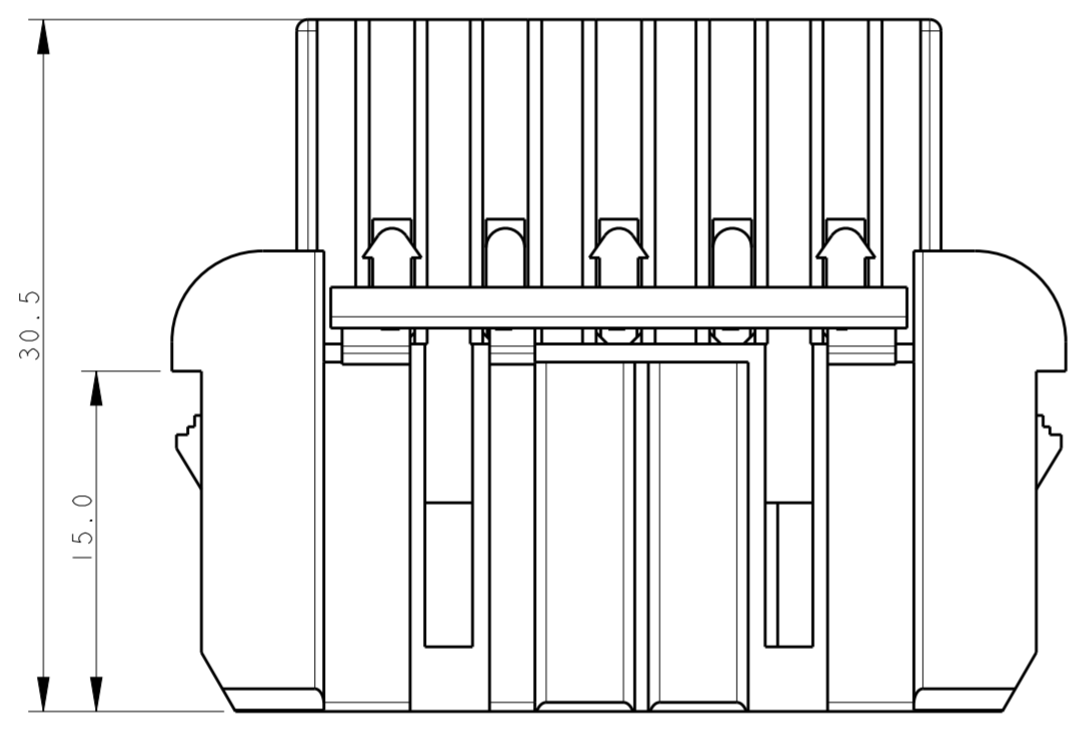
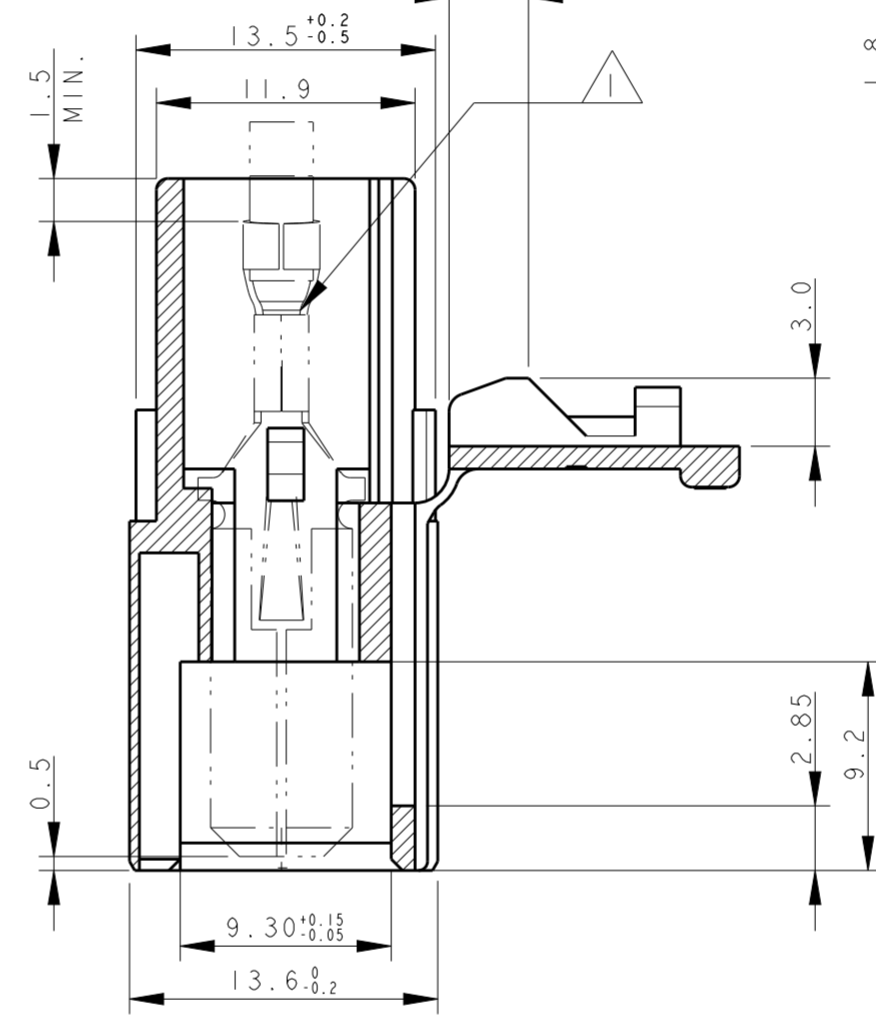

- ① TYPICAL CAVITY SUITABLE FOR:
FASTIN-FASTON TAB CONTACTS 6.3 mm SRS:
P/N: 293041, 0.3-1.0 mm² WIRE RANGE
60294, 0.3-0.8 mm² WIRE RANGE
160691, 0.3-0.8 mm² WIRE RANGE
AMPLIVAR CONTACTS:
P/N: 141051, 0.1-0.5 mm² WIRE RANGE
142411, 0.3-1.6 mm² WIRE RANGE
MAX. INSULATION DIA. 2.8 mm,
MAX. INSULATION CRIMP WIDTH 3.3 mm.
- ② PA UNFILLED, UL 94-V2, NATURE COLOUR ACCORDING TO IEC 60335-1 NORM.
- ③ PA66 UNFILLED, UL 94-V2, NATURE COLOUR
- ④ TRADEMARK AND PART NUMBER OPTIONAL POSITION.
- ⑤ CIRCUIT IDENTIFICATION NUMBERS, 1 TO 5.
- ⑥ POLARIZATION KEYS DIMENSIONS AND POSITIONS ARE ACCORDING TO "RAST 5" NORM RAST CODE 05-B, 05-D.
- ⑦ PRELIMINARY - NO RELEASED FOR PRODUCTION
- ⑧ PA66 UNFILLED, UL94-V0, GWEPTE 750°C NO FLAME ACCORDING TO IEC-60335-1

PANEL CUT OFF DIMENSIONS SCALE 1:1

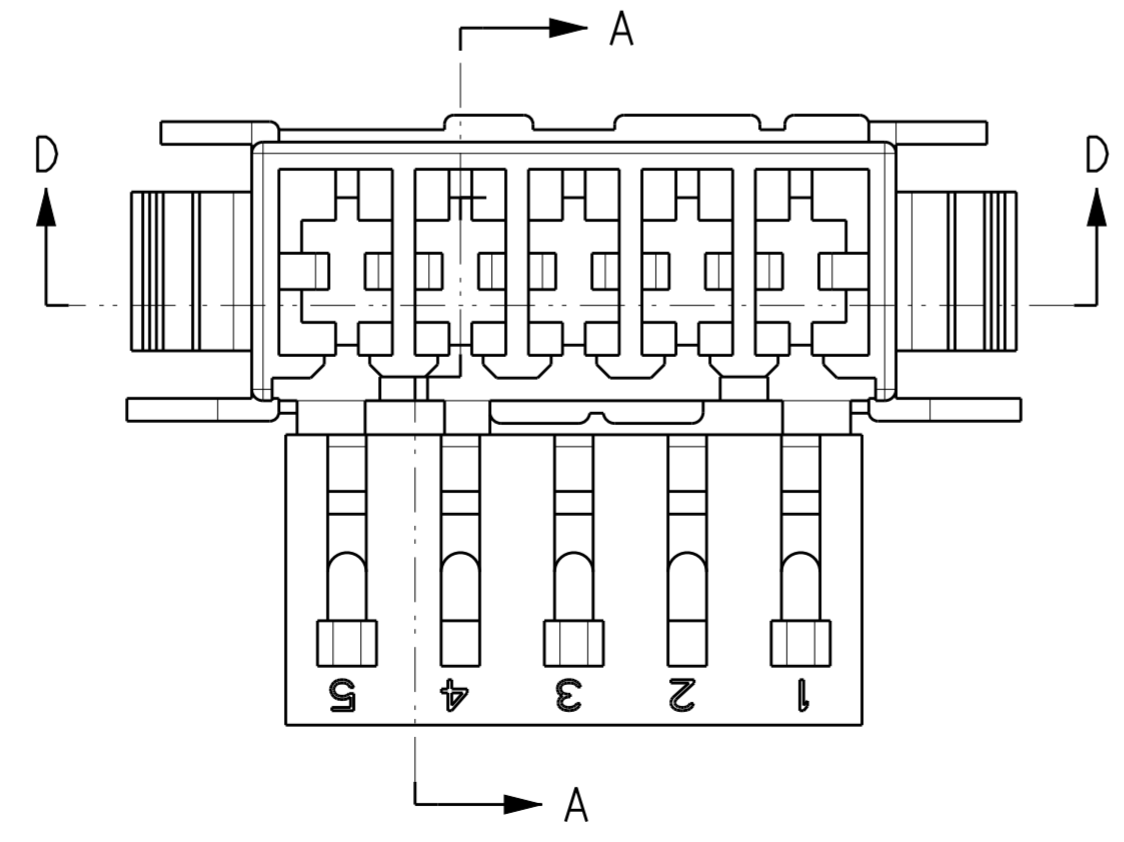
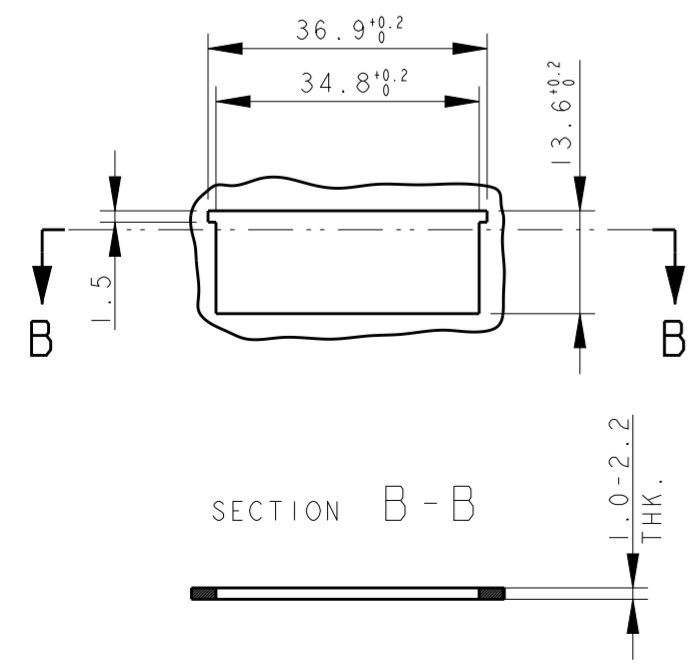

THIS DRAWING IS A CONTROLLED DOCUMENT FOR TYCO ELECTRONICS CORPORATION. IT IS SUBJECT TO CHANGE AND THE CONTROLLING ENGINEERING ORGANIZATION SHOULD BE CONTACTED FOR THE LATEST REVISION.		DWN: H. YAALI CHK: G. TURCO APVD: -	06 JUN 2005 Tyco Electronics AMP Italia S.R.L. C.so F.lli Cervi, 15 COLLEGNO (TO)
DIMENSIONS: mm TOLERANCES UNLESS OTHERWISE SPECIFIED: 0 PLC ± 1 PLC ±0.3 2 PLC ± 3 PLC ± 4 PLC ± ANGLES ±° FINISH	PRODUCT SPEC: 108-20256 APPLICATION SPEC: - WEIGHT: -	NAME: 5POS. FASTIN-FASTON TAB HOUSING RAST 5, PANEL MOUNT VERSION. SIZE: A2 CAGE CODE: 00779 DRAWING NO: C-1241857	RESTRICTED TO: - SCALE: 3:1 SHEET: 1 OF 1 REV: D4
MATERIAL: SEE TABLE		CUSTOMER DRAWING	NOTE COLOUR MATERIAL P/N NATURAL SEE NOTE 2 9-1241857-5 NATURAL SEE NOTE 8 1-1241857-5 NATURAL SEE NOTE 3 0-1241857-5