

Structure Silicon monolithic integrated circuit
 Product name Audio signal switcher IC for DVD recorders
 Type **BD3826FS**

Features

[Power Supply]

- Vcc ±5V (for Signal), +12V (for Function Switch)

[Audio switch]

- 2-inputs 1-output, 2 circuits built-in, without mute function
- 3-inputs 1-output, 2 circuits built-in, with mute function
- 5-inputs 1-output, 2 circuits built-in, with mute function
- THD 0.002% typ.
- S/N 90dB typ.
- Crosstalk -100dB typ.
- Output resistance 350Ω max.

[Function switch]

- 2 circuits built-in

○Absolute Maximum Ratings (Ta=25°C)

Parameter	Symbol	Rating	Unit
Supply voltage 1	Vcc1	+6.0	V
Supply voltage 2	Vcc2	-7.0	V
Supply voltage 3	Vcc3	+13.0	V
Power dissipation	Pd	950 ※1	mW
Input Voltage	Vin	Vcc2~Vcc1+0.2	V
Operating temperature range	Topr	-25 ~ +75	°C
Storage temperature range	Tstg	-55 ~ +125	°C

※1 Deratings is done at 9.5mW/°C above Ta=25°C.

○Operating Range

Parameter	Symbol	Range	Unit
Supply voltage 1	Vcc1	+4.5~+5.5	V
Supply voltage 2	Vcc2	-6.5~-4.5	V
Supply voltage 3	Vcc3	+11.5~+12.5	V

※ This product is not designed for protection against radioactive rays.

Status of this document

The Japanese version of this document is the formal specification.

A customer may use this translation version only for a reference to help reading the formal version.

If there are any differences in translation version of this document, formal version takes priority.

Application example

- ROHM cannot provide adequate confirmation of patents.
- The product described in this specification is designed to be used with ordinary electronic equipment or devices (such as audio-visual equipment, office-automation equipment, communications devices, electrical appliances, and electronic toys). Should you intend to use this product with equipment or devices which require an extremely high level of reliability and the malfunction of which would directly endanger human life (such as medical instruments, transportation equipment, aerospace machinery, nuclear-reactor controllers, fuel controllers and other safety devices), please be sure to consult with our sales representative in advance.
- ROHM assumes no responsibility for use of any circuits described herein, conveys no license under any patent or other right, and makes no representations that the circuits are free from patent infringement.

○Electrical characteristics (Unless otherwise noted, Ta=25°C, Vcc1=+5.0V, Vcc2=-5.0V, Vcc3=+12V)

Item	Symbol	Limit			Unit	Conditions
		MIN.	TYP.	MAX.		
<Device total>						
Circuit current 1	I _{ATYP1}	3.0	5.5	8.0	mA	Vcc1=+5V, Vcc2=-5V No signal, Vcc1 circuit current
Circuit current 2	I _{ATYP2}	2.5	7.5	12.5	mA	Vcc3=+12V FS : H
<AUX, L1, AD Lch,Rch OUT>						
Frequency Characteristic	F _{FC}	-0.5	0.0	0.5	dB	Vin=2.2Vrms, f=20kHz/20Hz R _L =47kΩ
Distortion 1	F _{DIS1}	—	0.002	0.1	%	Vin=2.2Vrms, f=1kHz R _L =47kΩ
Distortion 2	F _{DIS2}	—	0.003	1	%	Vin=2.7Vrms, f=1kHz R _L =47kΩ
S/N	F _{SN}	80	90	—	dB	Vin=2.2Vrms, f=1kHz, R _L =47kΩ Without Filter
Output Impedance	Z _O	—	260	350	Ω	Vin=0V
MUTE Attenuation	F _{MUTE}	—	-100	-75	dB	Vin=2.2Vrms, f=1kHz R _g =600Ω, R _L =47kΩ
SW1 Crosstalk within the switch	F _{SWCRS1}	—	-100	-85	dB	Vin=2.2Vrms, f=1kHz, R _g =600Ω, R _L =47kΩ
SW2 Crosstalk within the switch	F _{SWCRS2}	—	-100	-85	dB	Vin=2.2Vrms, f=1kHz, R _g =600Ω, R _L =47kΩ
SW3 Crosstalk within the switch	F _{SWCRS3}	—	-100	-85	dB	Vin=2.2Vrms, f=1kHz, R _g =600Ω, R _L =47kΩ
Crosstalk between channels (AUX_Lch,Rch)	F _{CHCRS1}	—	-100	-85	dB	Vin=2.2Vrms, f=1kHz, R _g =600Ω, R _L =47kΩ
Crosstalk between channels (L1_Lch,Rch)	F _{CHCRS2}	—	-100	-85	dB	Vin=2.2Vrms, f=1kHz, R _g =600Ω, R _L =47kΩ
Crosstalk between channels (AD_Lch,Rch)	F _{CHCRS3}	—	-100	-85	dB	Vin=2.2Vrms, f=1kHz, R _g =600Ω, R _L =47kΩ
FS_AUX,FS_L1 Output Voltage H	V _{FSOH}	10.0	11.0	12.0	V	R _L =10kΩ
FS_AUX,FS_L1 Output Voltage M	V _{FSOM}	5	5.75	6.5	V	R _L =10kΩ
FS_AUX,FS_L1 Output Voltage L	V _{FSOL}	0	0	1.5	V	R _L =10kΩ
ASW Input Voltage H	V _{ASWH}	3.5	—	Vcc1	V	
ASW Input Voltage L	V _{ASWL}	0	—	1.5	V	
FS_AUX, FS_L1 Input Voltage H	V _{FSIH}	3.9	—	Vcc1	V	
FS_AUX, FS_L1 Input Voltage M	V _{FSIM}	1.85	—	3.1	V	
FS_AUX, FS_L1 Input Voltage L	V _{FSIL}	0	—	0.85	V	

○Switch truth table

SW1

ASW1	ASW2	AUX_OUT
L	L	TU_IN
L	H	DA_IN
H	L	L1_IN
H	H	MUTE

Lch, Rch common specification

SW2

ASW3	L1_OUT
L	DA_IN
H	AUX_IN

Lch, Rch common specification

SW3

ASW4	ASW5	ASW6	AD_OUT
L	L	L	TU_IN
L	L	H	L1_IN
L	H	L	L2_IN
L	H	H	AUX_IN
H	L	L	L4_IN
H	L	H	MUTE
H	H	L	MUTE
H	H	H	MUTE

Lch, Rch common specification

※ When the ASW pin is open,

- ASW1 = H
- ASW2 = L
- ASW3 = H
- ASW4 = L
- ASW5 = L
- ASW6 = L

○Outer dimensions

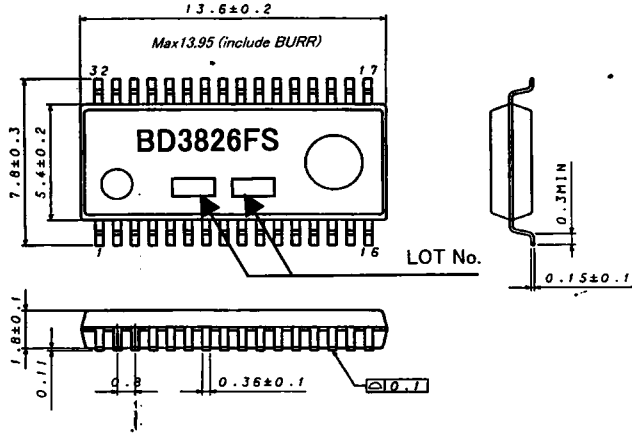

(SSOP-A32) (UNIT: mm)

○Pin Number*Pin name

Pin No.	Pin name
1	TU_L_IN
2	TU_R_IN
3	ASW1
4	ASW2
5	DA_L_IN
6	DA_R_IN
7	ASW3
8	ASW4
9	-5V
10	L4_L_IN
11	L4_R_IN
12	+5V
13	L2_L_IN
14	L2_R_IN
15	ASW5
16	ASW6
17	AD_R_OUT
18	AD_L_OUT
19	FS_L1_OUT
20	FS_AUX_OUT
21	+12V
22	L1_R_OUT
23	L1_L_OUT
24	GND
25	L1_R_IN
26	L1_L_IN
27	FS_L1_IN
28	AUX_R_IN
29	AUX_L_IN
30	FS_AUX_IN
31	AUX_R_OUT
32	AUX_L_OUT

○Block diagram

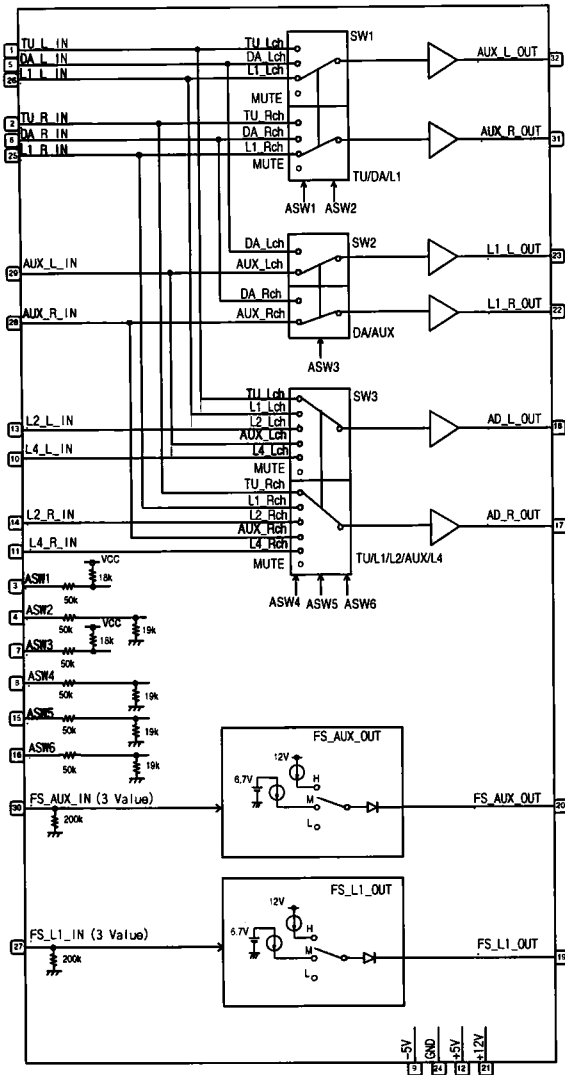

○Cautions on use

(1) Absolute maximum ratings

This LSI may be damaged if the absolute maximum ratings for the applied voltage, temperature range, or other parameters are exceeded. Therefore, avoid using a voltage or temperature that exceeds the absolute maximum ratings.

If it is possible that absolute maximum ratings will be exceeded, use fuses or other physical safety measures and determine ways to avoid exceeding the LSI's absolute maximum ratings.

(2) -5V pin's potential

Try to set the minimum voltage for -5V pin's potential, regardless of the operation mode.

Check that the voltage of each pin does not go below -5V pin's voltage, including transient phenomena.

(3) Thermal design

Ensure sufficient margins in the thermal design by taking in to account the allowable power dissipation during actual use modes.

(4) Shorting between pins and mounting errors

When mounting the LSI chip on a board, be very careful to set the chip's orientation and position precisely.

When the power is turned on, the LSI may be damaged if it is not mounted correctly. The LSI may also be damaged if a short occurs (due to a foreign object, etc.) between two pins, between a pin and the power supply, or between a pin and the GND.

(5) Operation in strong magnetic fields

Note with caution that operation faults may occur when this LSI operates in a strong magnetic field.

(6) Reverse audio output

If an excessive signal (approximately 2.9 Vrms) is input to an audio channel, output will be reversed.

(When $V_{CC1,2} = \pm 5\text{ V}$, and $T_a = 25^\circ\text{C}$). Caution is required when using a signal exceeding 2.7 Vrms.

(7) Power-on sequence

An output shunting switch is included as a countermeasure against pops that may occur when the power supply is turned on.

To ensure reliable operation of this shunt switch, whenever a negative power supply is applied to the audio system, be sure to subsequently apply a positive power supply for audio along with the power supply for video.

(8) Audio input terminator

The audio input block's input bias current is output from the IC as 4 to 8 nA (Typ.).

Since there is no built-in input termination resistance, when using a coupling input connect an external input termination resistance and confirm that there is a flow path for the input bias current.

Notes

- No technical content pages of this document may be reproduced in any form or transmitted by any means without prior permission of ROHM CO.,LTD.
- The contents described herein are subject to change without notice. The specifications for the product described in this document are for reference only. Upon actual use, therefore, please request that specifications to be separately delivered.
- Application circuit diagrams and circuit constants contained herein are shown as examples of standard use and operation. Please pay careful attention to the peripheral conditions when designing circuits and deciding upon circuit constants in the set.
- Any data, including, but not limited to application circuit diagrams information, described herein are intended only as illustrations of such devices and not as the specifications for such devices. ROHM CO.,LTD. disclaims any warranty that any use of such devices shall be free from infringement of any third party's intellectual property rights or other proprietary rights, and further, assumes no liability of whatsoever nature in the event of any such infringement, or arising from or connected with or related to the use of such devices.
- Upon the sale of any such devices, other than for buyer's right to use such devices itself, resell or otherwise dispose of the same, no express or implied right or license to practice or commercially exploit any intellectual property rights or other proprietary rights owned or controlled by
- ROHM CO., LTD. is granted to any such buyer.
- Products listed in this document are no antiradiation design.

The products listed in this document are designed to be used with ordinary electronic equipment or devices (such as audio visual equipment, office-automation equipment, communications devices, electrical appliances and electronic toys).

Should you intend to use these products with equipment or devices which require an extremely high level of reliability and the malfunction of which would directly endanger human life (such as medical instruments, transportation equipment, aerospace machinery, nuclear-reactor controllers, fuel controllers and other safety devices), please be sure to consult with our sales representative in advance.

About Export Control Order in Japan

Products described herein are the objects of controlled goods in Annex 1 (Item 16) of Export Trade Control Order in Japan.

In case of export from Japan, please confirm if it applies to "objective" criteria or an "informed" (by MITI clause) on the basis of "catch all controls for Non-Proliferation of Weapons of Mass Destruction.

Thank you for your accessing to ROHM product informations.
More detail product informations and catalogs are available,
please contact your nearest sales office.

Please contact our sales offices for details ;

U.S.A / San Diego	TEL : +1(858)625-3630	FAX : +1(858)625-3670
Atlanta	TEL : +1(770)754-5972	FAX : +1(770)754-0691
Dallas	TEL : +1(972)312-8818	FAX : +1(972)312-0330
Germany / Dusseldorf	TEL : +49(2154)9210	FAX : +49(2154)921400
United Kingdom / London	TEL : +44(1)908-282-666	FAX : +44(1)908-282-528
France / Paris	TEL : +33(0)1 56 97 30 60	FAX : +33(0) 1 56 97 30 80
China / Hong Kong	TEL : +852(2)740-6262	FAX : +852(2)375-8971
Shanghai	TEL : +86(21)6279-2727	FAX : +86(21)6247-2066
Dilian	TEL : +86(411)8230-8549	FAX : +86(411)8230-8537
Beijing	TEL : +86(10)8525-2483	FAX : +86(10)8525-2489
Taiwan / Taipei	TEL : +866(2)2500-6956	FAX : +866(2)2503-2869
Korea / Seoul	TEL : +82(2)8182-700	FAX : +82(2)8182-715
Singapore	TEL : +65-6332-2322	FAX : +65-6332-5662
Malaysia / Kuala Lumpur	TEL : +60(3)7958-8355	FAX : +60(3)7958-8377
Philippines / Manila	TEL : +63(2)807-6872	FAX : +63(2)809-1422
Thailand / Bangkok	TEL : +66(2)254-4890	FAX : +66(2)256-6334

Japan /
(Internal Sales)

Tokyo	2-1-1, Yaesu, Chuo-ku, Tokyo 104-0082	TEL : +81(3)5203-0321	FAX : +81(3)5203-0300
Yokohama	2-4-8, Shin Yokohama, Kohoku-ku, Yokohama, Kanagawa 222-8575	TEL : +81(45)476-2131	FAX : +81(45)476-2128
Nagoya	Dainagayo Building 9F 3-28-12, Meieki, Nakamura-ku, Nagoya, Aichi 450-0002	TEL : +81(52)581-8521	FAX : +81(52)561-2173
Kyoto	579-32 Higashi Shiokouji-cho, Karasuma Nishi-iru, Shiokoujidori, Shimogyo-ku, Kyoto 600-8216	TEL : +81(75)311-2121	FAX : +81(75)314-6559

(Contact address for overseas customers in Japan)

Yokohama	TEL : +81(45)476-9270	FAX : +81(045)476-9271
----------	-----------------------	------------------------