

DO NOT SCALE FROM THIS PRINT

DESIGNED & DIMENSIONED IN MILLIMETERS [INCHES]

BNC7T-J-P-XX-RA-BMXD

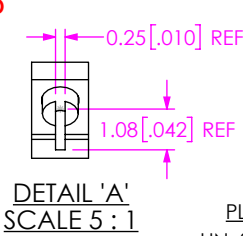
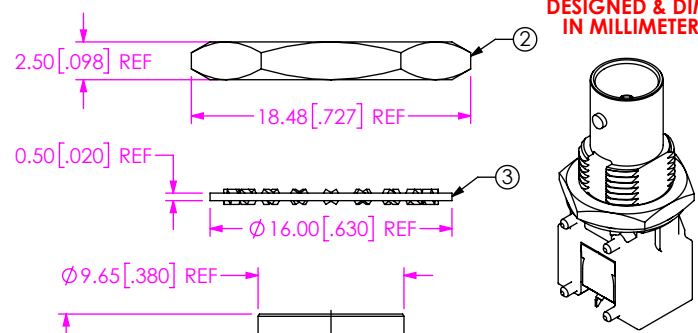

GENDER  
-J: JACK  
  
TYPE  
-P: PCB

TERMINATION  
-BM1D: .062" BOARD, DIE CAST BULKHEAD THROUGH HOLE & MIXED TECHNOLOGY  
-BM2D: .125" BOARD, DIE CAST BULKHEAD THROUGH HOLE & MIXED TECHNOLOGY  
  
ORIENTATION  
-RA: RIGHT ANGLE

PLATING SPECIFICATION  
-HN: 30μ" GOLD CENTER CONTACT  
-GN: 10μ" GOLD CENTER CONTACT

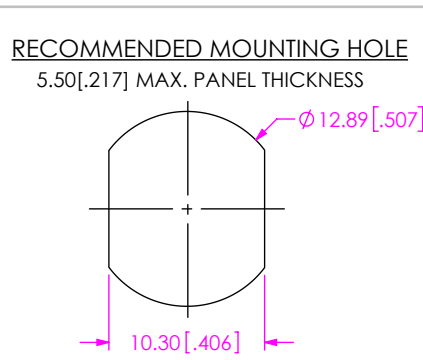
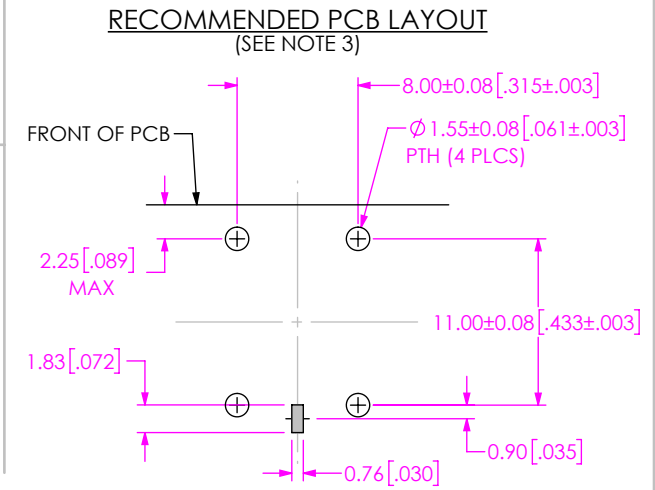
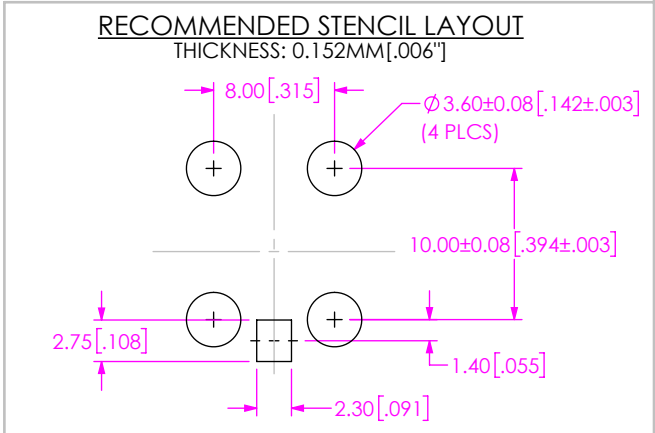
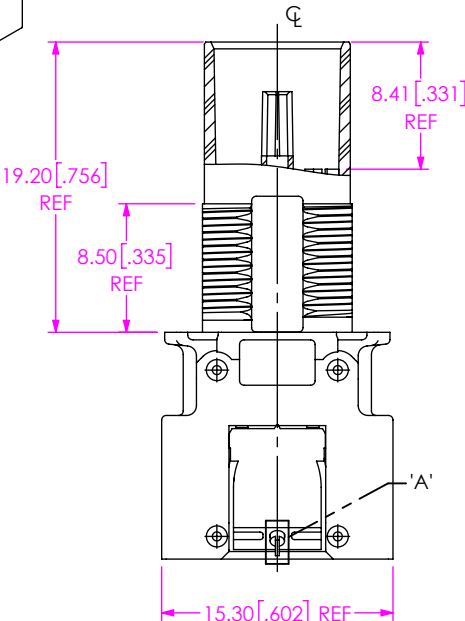
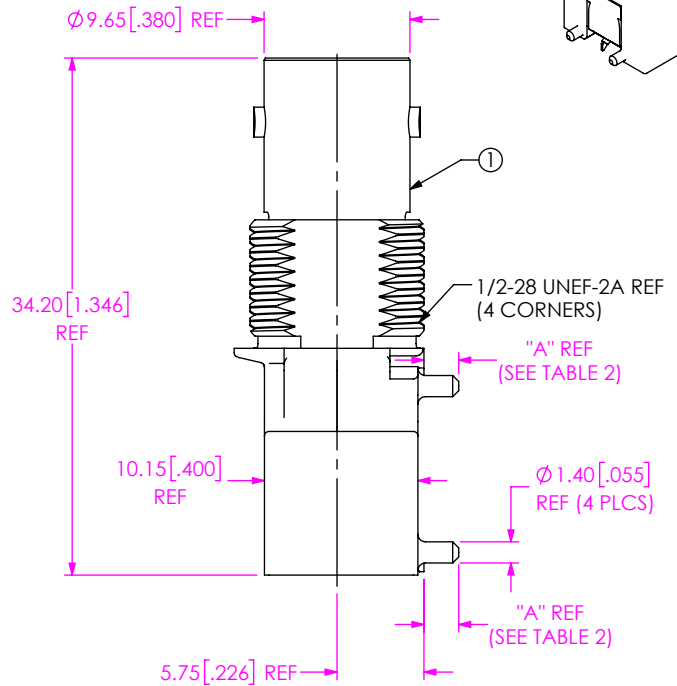

FIG 1  
BNC7T-J-P-XX-RA-BM1D SHOWN

TABLE 1

ITEM	COMPONENT	-HN	-GN
1	SUB ASSEMBLY	SUB-BNC7T-J-P-XX-RA-BMXD (SEE TABLE 2)	
2	NUT	BTNC-NUT-001-N	
3	LOCK WASHER	BTNC-LWAS-001-N	

TABLE 2

STYLE	-HN	-GN	"A"
-BM1D	SUB-BNC7T-J-P-HN-RA-BM1D	SUB-BNC7T-J-P-GN-RA-BM1D	2.30 [0.091]
-BM2D	SUB-BNC7T-J-P-HN-RA-BM2D	SUB-BNC7T-J-P-GN-RA-BM2D	4.30 [0.169]

NOTES:

1. © REPRESENTS A CRITICAL DIMENSION.
2. SEE CO-RF-WI-3040-M RF PACKAGING STANDARD FOR PACKAGING INSTRUCTIONS. PRODUCT TO BE PACKAGED IN TRAY (TY-BNC005) WITH COVER (TY-BNC005). NUT AND WASHER TO BE BULK PACKAGED SEPARATELY.
3. THIS IS A GENERAL FOOTPRINT AND IS NOT OPTIMIZED FOR ELECTRICAL PERFORMANCE, CONTACT SIG@SAMTEC.COM FOR ASSISTANCE WITH ELECTRICAL LAYOUT.

PROPRIETARY NOTE  
THIS DOCUMENT CONTAINS CONFIDENTIAL AND PROPRIETARY INFORMATION AND ALL DESIGN, MANUFACTURING, REPRODUCTION, USE, PATENT RIGHTS AND SALES RIGHTS ARE EXPRESSLY RESERVED BY SAMTEC, INC. THIS DOCUMENT SHALL NOT BE DISCLOSED, IN WHOLE OR PART, TO ANY UNAUTHORIZED PERSON OR ENTITY NOR REPRODUCED, TRANSFERRED OR INCORPORATED IN ANY OTHER PROJECT IN ANY MANNER WITHOUT THE EXPRESS WRITTEN CONSENT OF SAMTEC, INC.

MATERIAL: DO NOT SCALE DRAWING  
SHELL: ZINC SHEET SCALE: 2:1  
NUT, WASHER: BRASS  
CONTACT: COPPER ALLOY  
INSULATOR: LCP

520 PARK EAST BLVD, NEW ALBANY, IN 47150  
PHONE: 812-944-6733 FAX: 812-948-5047  
e-Mail info@SAMTEC.com code 55322

DESCRIPTION: 75 OHM, BNC RA JACK ASSEMBLY  
DWG. NO. BNC7T-J-P-XX-RA-BMXD  
BY: SHERRY W 11/10/2017 SHEET 1 OF 1