

FEATURES

- Up to 1.25Gbps operation
- Low noise
- Chatter-Free /LOS Generation
- PECL /LOS Output
- TTL /EN Input
- Differential PECL inputs for data
- /EN input is TTL with internal 27K pull-up
- Single power supply
- Designed for use with SY88902 and SY88904
- Available in a tiny 10-pin (3mm x3 mm) MSOP

APPLICATIONS

- 1.25Gbps Gigabit Ethernet
- 531Mbps and 1062Mbps Fibre Channel
- 622Mbps SONET
- Gigabit Interface Converter

DESCRIPTION

The SY88913 limiting post amplifier with its high gain and wide bandwidth is ideal for use as a post amplifier in fiber-optic receivers with data rates up to 1.25Gbps. Signals as small as 5mVp-p can be amplified to drive devices with PECL inputs. The SY88913 generates a chatter-free PECL Loss of Signal (/LOS).

The SY88913 incorporates a programmable level detect function to identify when the input signal has been lost. This information can be fed back to the /EN input of the device to maintain stability under loss of signal conditions. Using LOSLVL pin the sensitivity of the level detect can be adjusted. The LOSLVL voltage can be set by connecting a resistor divider between VCC and VREF, Figure 2. Figure 3 shows the relationship between input level sensitivity and the voltage set on LOSLVL. Figure 4 shows the relationship between input level sensitivity and resistor divider ratio.

BLOCK DIAGRAM

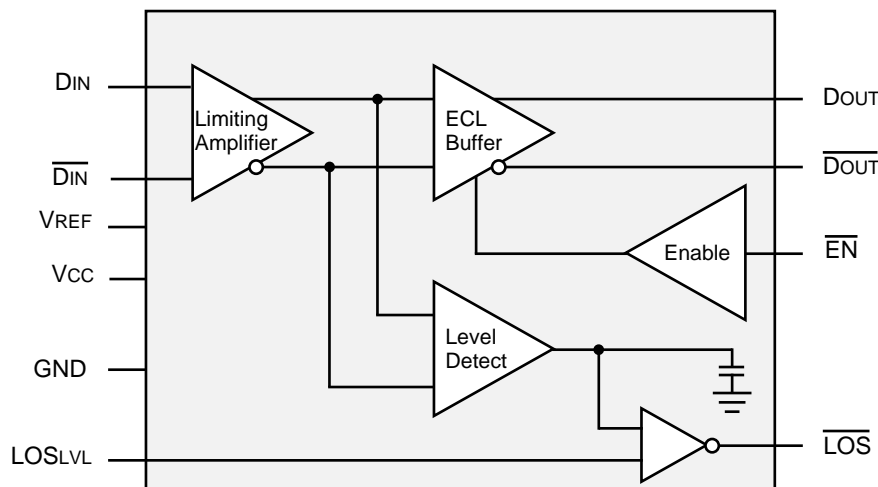

PACKAGE/ORDERING INFORMATION

Ordering Information

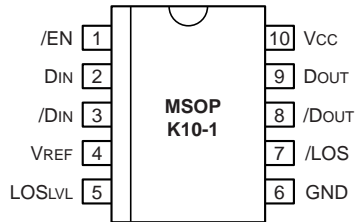

10-Pin MSOP (K10-1)

Part Number	Package Type	Operating Range	Package Marking	Lead Finish
SY88913KC	K10-1	Commercial	913	Sn-Pb
SY88913KCTR ⁽¹⁾	K10-1	Commercial	913	Sn-Pb
SY88913KG	K10-1	Commercial	913 with Pb-Free bar-line indicator	Pb-Free NiPdAu
SY88913KGTR ⁽¹⁾	K10-1	Commercial	913 with Pb-Free bar-line indicator	Pb-Free NiPdAu

Note:

1. Tape and Reel.

PIN NAMES

GENERAL DESCRIPTION

Pin	Type	Function
DIN	Data Input	Data Input
/DIN	Data Input	Inverting Data Input
LOS LVL	Input	Loss of Signal Level Set
/EN	TTL Input	Output Enable (active Low)
/LOS	PECL Output	Loss of Signal Indicator (active Low)
GND	Ground	Ground
DOUT	PECL Output	Data Output
/DOUT	PECL Output	Inverting Data Output
VCC	Power Supply	Positive Power Supply
VREF	Output	Reference Voltage Output for LOS Level Set (see Fig. 2)

General

The SY88913 is an integrated limiting amplifier intended for high-frequency fiber-optic applications. The circuit connects to typical transimpedance amplifiers found within a fiber-optics link. The linear signal output from a transimpedance amplifier can contain significant amounts of noise, and may vary in amplitude over time. The SY88913 limiting amplifier quantizes the signal and outputs a voltage-limited waveform.

The TTL /EN pin allows the user to disable the signal without removing the input signal.

ABSOLUTE MAXIMUM RATINGS⁽¹⁾

Symbol	Rating	Value	Unit
V _{CC}	Power Supply Voltage	0 to +7.0	V
D _{IN} , /D _{IN}	Input Voltage	0 to V _{CC}	V
D _{OUT} , /D _{OUT} , /LOS	Output Voltage (with 50Ω load)	V _{CC} -2.5, V _{CC} +0.3	V
T _A	Operating Temperature Range	-40 to +85	°C
T _{store}	Storage Temperature Range	-55 to +125	°C

Note:

1. Permanent device damage may occur if absolute maximum ratings are exceeded. This is a stress rating only and functional operation is not implied at conditions other than those detailed in the operational sections of this data sheet. Exposure to absolute maximum rating conditions for extended periods may affect device reliability.

DC ELECTRICAL CHARACTERISTICS

V_{CC} = +5V ±10%, R_{LOAD} = 50Ω to V_{CC}-2V, T_A = -40°C to +85°C.

Symbol	Parameter	T _A = -40°C		T _A = 0°C		T _A = +25°C			T _A = +85°C		Unit
		Min.	Max.	Min.	Max.	Min.	Typ.	Max.	Min.	Max.	
I _{CC}	Power Supply Current ⁽¹⁾	—	35	—	35	—	21	35	—	35	mA
I _{IL}	/EN Input LOW Current	-0.3 ⁽⁵⁾	—	-0.3 ⁽⁵⁾	—	-0.3 ⁽⁵⁾	—	—	-0.3 ⁽⁵⁾	—	mA
I _{IH}	/EN Input HIGH Current	—	20 ⁽²⁾ 100 ⁽³⁾	—	20 ⁽²⁾ 100 ⁽³⁾	—	—	20 ⁽²⁾ 100 ⁽³⁾	—	20 ⁽²⁾ 100 ⁽³⁾	μA
V _{CMR}	Common Mode Range	GND +2.0	V _{CC} -1.0	GND +2.0	V _{CC} -1.0	GND +2.0	—	V _{CC} -1.0	GND +2.0	V _{CC} -1.0	V
V _{offset}	Differential Output Offset	—	±100	—	±100	—	—	±100	—	±100	mV
LOS _{LVL}	LOS _{LVL} Level	V _{REF}	V _{CC}	V _{REF}	V _{CC}	V _{REF}	—	V _{CC}	V _{REF}	V _{CC}	V
V _{OH}	DOUT and /DOUT HIGH Output	V _{CC} -1085	V _{CC} -880	V _{CC} -1025	V _{CC} -880	V _{CC} -1025	V _{CC} -955	V _{CC} -880	V _{CC} -1025	V _{CC} -880	mV
V _{OL}	DOUT and /DOUT LOW Output	V _{CC} -1830	V _{CC} -1555	V _{CC} -1810	V _{CC} -1620	V _{CC} -1810	V _{CC} -1705	V _{CC} -1620	V _{CC} -1810	V _{CC} -1620	mV
V _{REF}	Reference Supply ⁽⁴⁾	V _{CC} -2.625	V _{CC} -2.325	V _{CC} -2.625	V _{CC} -2.325	V _{CC} -2.625	V _{CC} -2.475	V _{CC} -2.325	V _{CC} -2.625	V _{CC} -2.325	V
V _{IH}	/EN Input HIGH Voltage	2.0	—	2.0	—	2.0	—	—	2.0	—	V
V _{IL}	/EN Input LOW Voltage	—	0.8	—	0.8	—	—	0.8	—	0.8	V

Notes:

1. No output load.
2. V_{IN} = 2.7V.
3. V_{IN} = V_{CC}.
4. I_{REF} must be limited to be within -0.8mA (source) and 0.5mA (sink).
5. V_{IN} = 0.5V.

AC ELECTRICAL CHARACTERISTICS

$V_{CC} = +5V \pm 10\%$, $R_{LOAD} = 50\Omega$ to $V_{CC} - 2V$, $T_A = -40^\circ C$ to $+85^\circ C$.

Symbol	Parameter	$T_A = -40^\circ C$		$T_A = 0^\circ C$		$T_A = +25^\circ C$			$T_A = +85^\circ C$		Unit	Conditions
		Min.	Max.	Min.	Max.	Min.	Typ.	Max.	Min.	Max.		
PSRR	Power Supply ⁽¹⁾ Rejection Ratio	—	—	—	—	—	35	—	—	—	dB	Input referred, 55MHz
VID	Input Voltage Range	5	1800	5	1800	5	—	1800	5	1800	mV _{PP}	
t_r, t_f	Output Rise/Fall Time	—	350	—	350	—	200 <small>tr_{in}, t_{fin}</small>	350	—	350	ps	$V_{ID} > 100mV_{PP}$ $V_{ID} < 100mV_{PP}$
VOD	Differential Output Voltage Swing ⁽²⁾	—	—	—	—	—	600 200	—	—	—	mV mV	$V_{ID} = 15mV_{PP}$ $V_{ID} = 5mV_{PP}$
t_{OFFL}	/LOS Release Time ⁽³⁾ Minimum Input	—	0.5	—	0.5	—	0.1	0.5	—	0.5	μs	
t_{OFFH}	/LOS Release Time ⁽⁴⁾ Maximum Input	—	0.5	—	0.5	—	0.1	0.5	—	0.5	μs	
t_{ONL}	/LOS Assert Time ⁽³⁾	—	0.5	—	0.5	—	0.2	0.5	—	0.5	μs	
VSR	/LOS Sensitivity Range	5	50	5	50	5	—	50	5	50	mV _{PP}	
HYS	/LOS Hysteresis	2	8	2	8	2	4.6	8	2	8	dB	

Notes:

1. Input referred noise = RMS output noise/low frequency gain.
2. Input is 622MHz square wave.
3. Input is a 200MHz square wave, $t_r < 300ps$, $8mV_{PP}$.
4. Input is a 200MHz square wave, $t_r < 300ps$, $1.8V_{PP}$.

APPLICATION NOTE

Output Termination

The SY88913 outputs must be terminated with a 50Ω load to VCC – 2V (or Thevenin equivalent).

Layout and PCB Design

Since the SY88913 is a high-frequency component, performance can largely be determined by board layout and design. A common problem with high-gain amplifiers is feedback from the large swing outputs to the input via the power supply.

The SY88913 ground pin should be connected to the circuit board ground. Use multiple PCB vias close to the part to connect to ground. Avoid long, inductive runs which can degrade performance.

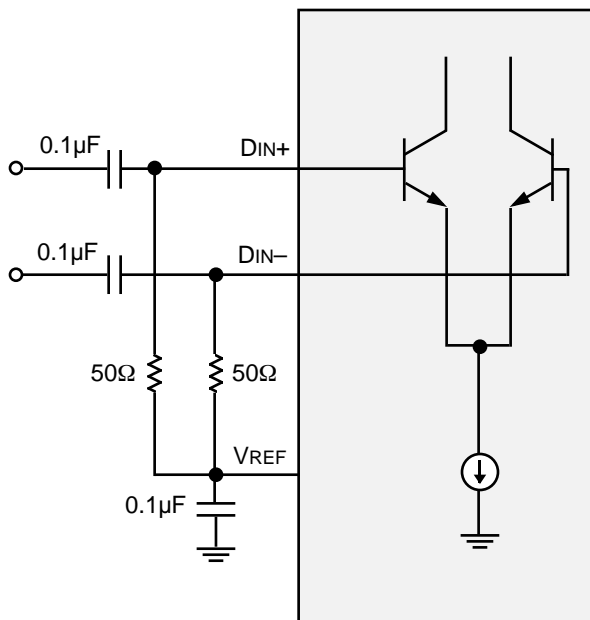
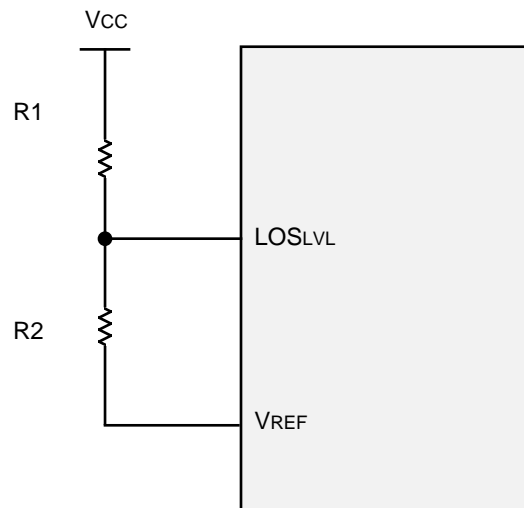

Figure 1. Differential Input Configuration



Notes:
 Resistor Divider = $R2 / (R1 + R2)$
 $R1 + R2 \geq 5k\Omega$

Figure 2. LOSLVL Circuit

PERFORMANCE CURVE

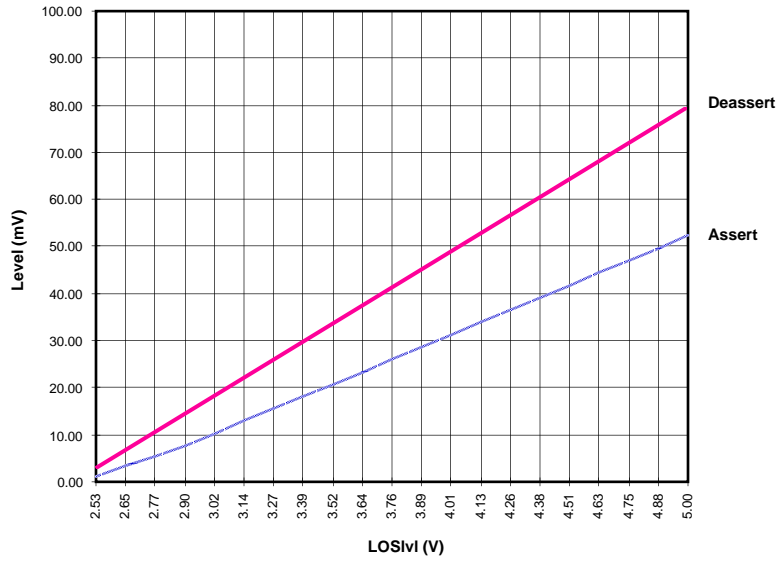

Figure 3. LOS Assert and Deassert Levels vs Resistor Divider

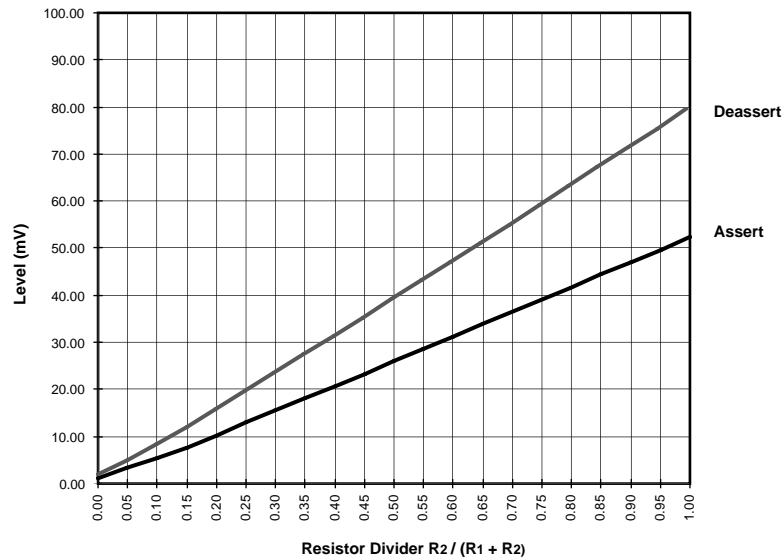
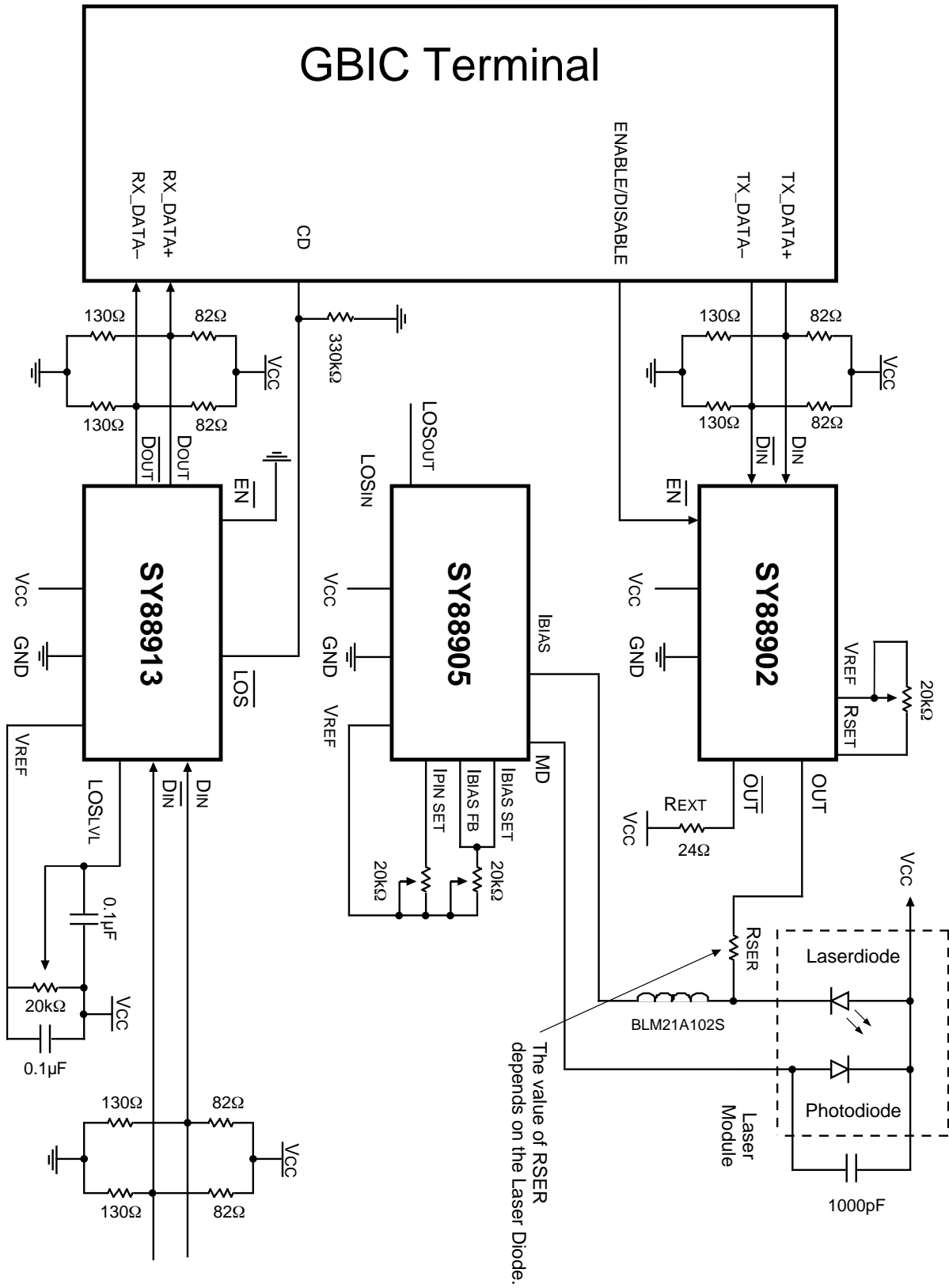
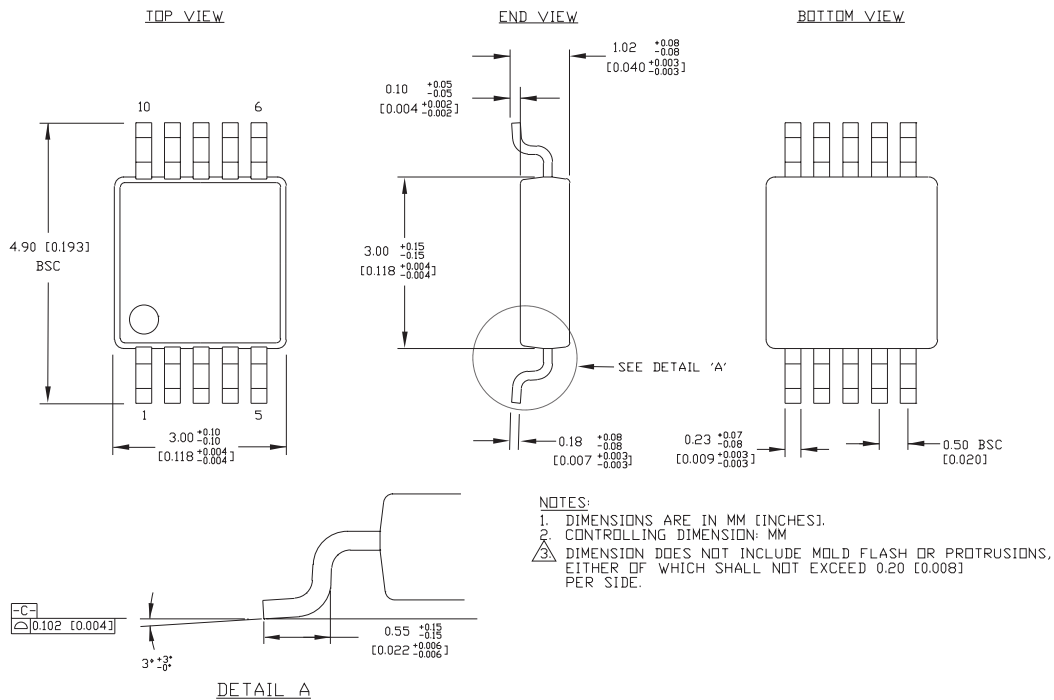

Figure 4. Resistor Divider R2 / (R1 + R2)

APPLICATION EXAMPLE FOR 3-CHIP SET SOLUTION



10 LEAD MSOP (K10-1)



Rev. 00

MICREL, INC. 2180 FORTUNE DRIVE SAN JOSE, CA 95131 USA

TEL + 1 (408) 944-0800 FAX + 1 (408) 474-1000 WEB <http://www.micrel.com>

The information furnished by Micrel in this data sheet is believed to be accurate and reliable. However, no responsibility is assumed by Micrel for its use. Micrel reserves the right to change circuitry and specifications at any time without notification to the customer.

Micrel Products are not designed or authorized for use as components in life support appliances, devices or systems where malfunction of a product can reasonably be expected to result in personal injury. Life support devices or systems are devices or systems that (a) are intended for surgical implant into the body or (b) support or sustain life, and whose failure to perform can be reasonably expected to result in a significant injury to the user. A Purchaser's use or sale of Micrel Products for use in life support appliances, devices or systems is at Purchaser's own risk and Purchaser agrees to fully indemnify Micrel for any damages resulting from such use or sale.

© 2005 Micrel, Incorporated.