

REVISIONS					
P.	LTN	DESCRIPTION	DATE	DMN	APVD
B		REVISED PER ECR-16-005516	25APR2016	DD	CS

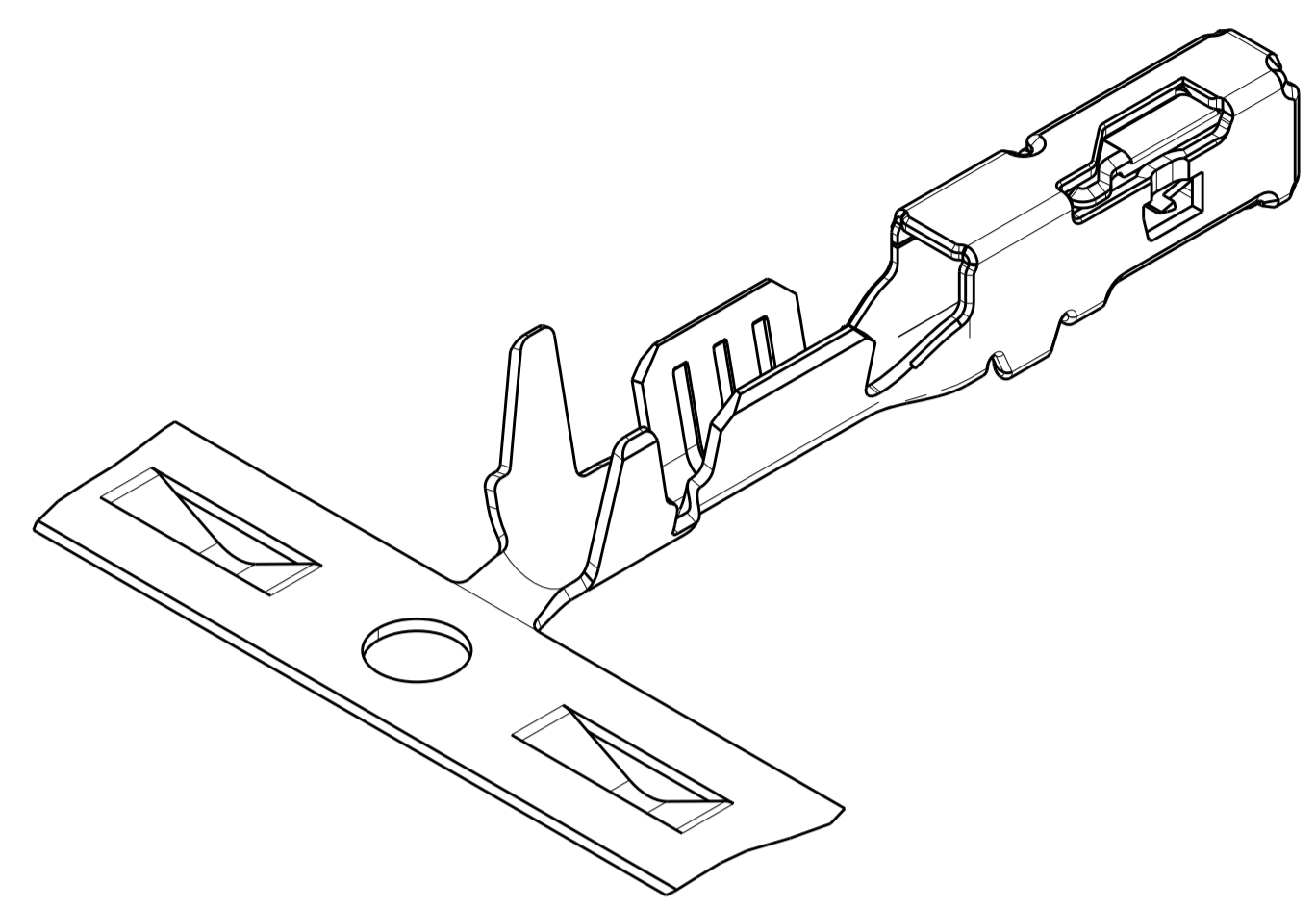

ISOMETRIC VIEW
SCALE 10:1

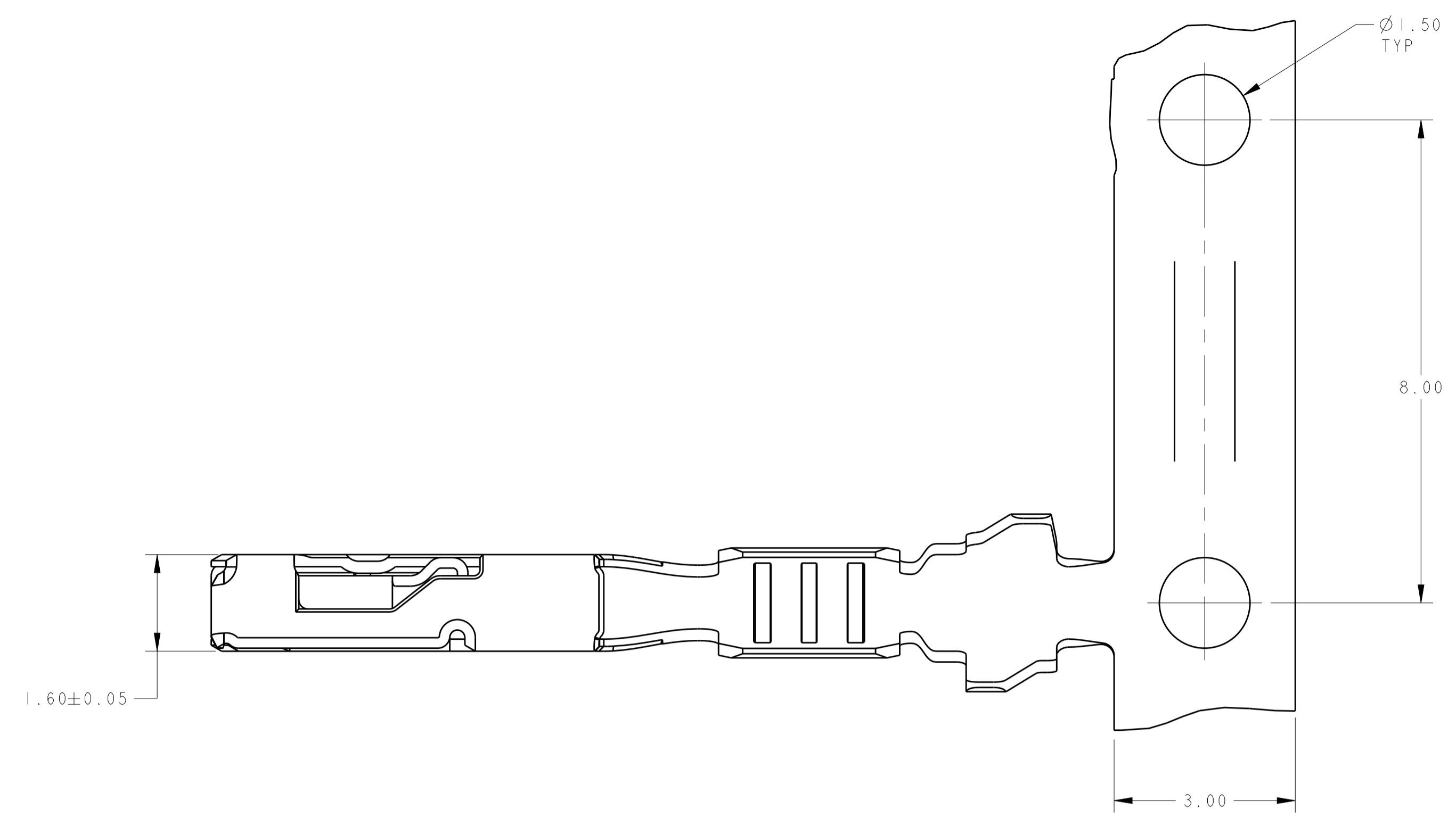
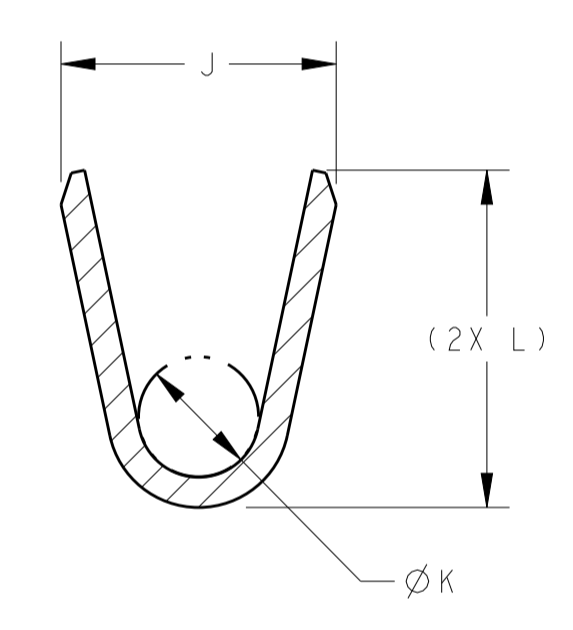
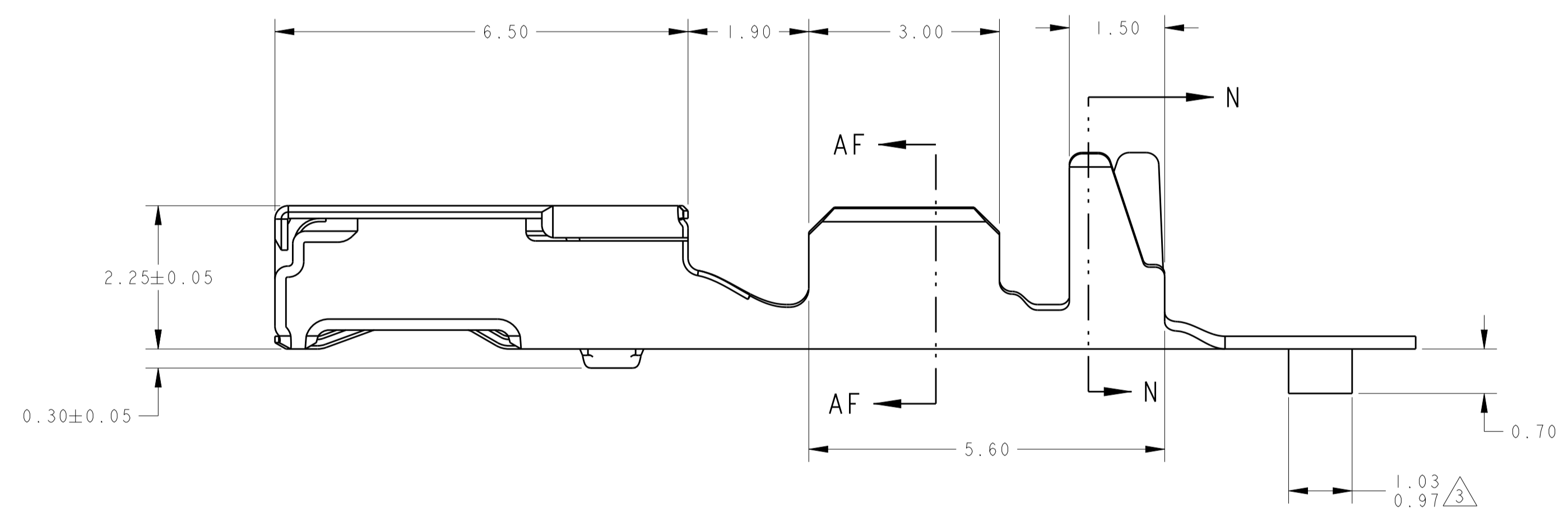

SECTION AF-AF
SCALE 20:1

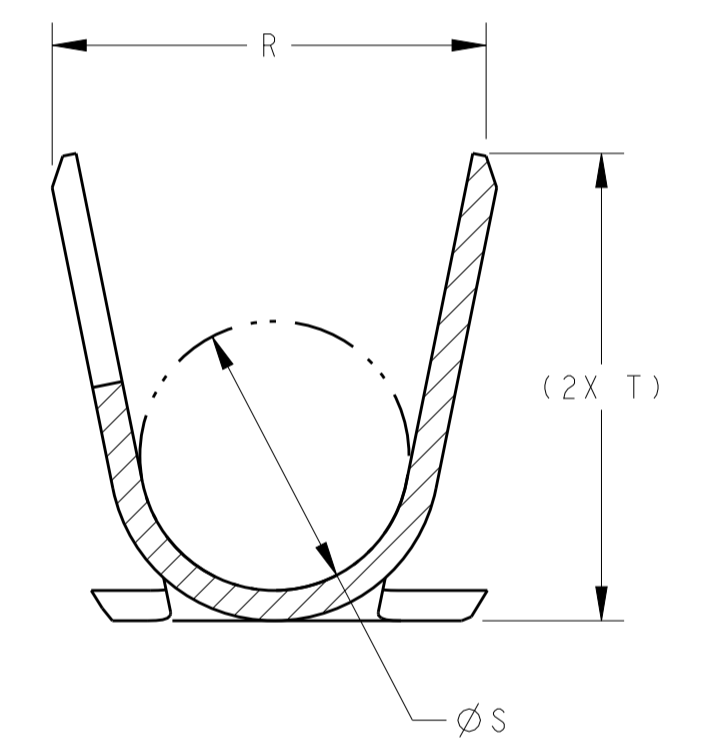

SECTION N-N
SCALE 20:1

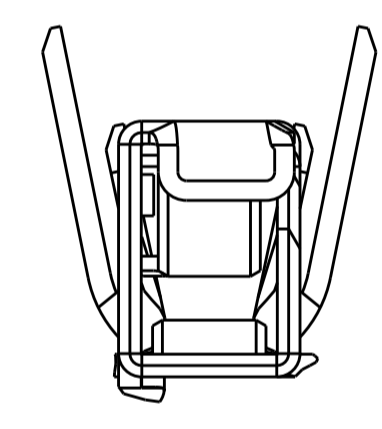

- 1 MATERIAL: 0.2mm THICK CuNiSi ALLOY
- 2 FINISH: PRE-PLATED WITH 1.00µm MIN BRIGHT TIN
- 3 MATERIAL ID FEATURE IN "DOWN" POSITION
- 4 THIS PRODUCT DESIGNED TO COMPLY WITH USCAR-2, REVISION 5 TEMP CLASS 3, MOUNTED TO ENGINE VIBRATION PROFILE
- 5 THIS PRODUCT IS DESIGNED TO BE COMPATIBLE WITH SEALED APPLICATIONS.
- 6 NORMAL FORCE 240 GRAMS REFERENCE.
- 7 TERMINAL HAS NYE LUBRICANTS NYETACT 568J-50-UV PERFORMANCE LUBE/GREASE APPLIED. THIS IS A WHITISH COLORED LUBE. AMOUNT AND VISIBILITY MAY VARY.
- 8 NOT INTENDED FOR SEALED APPLICATIONS.
- 9 SEALING CAPABILITY MUST BE EVALUATED ON AN APPLICATION BASIS.

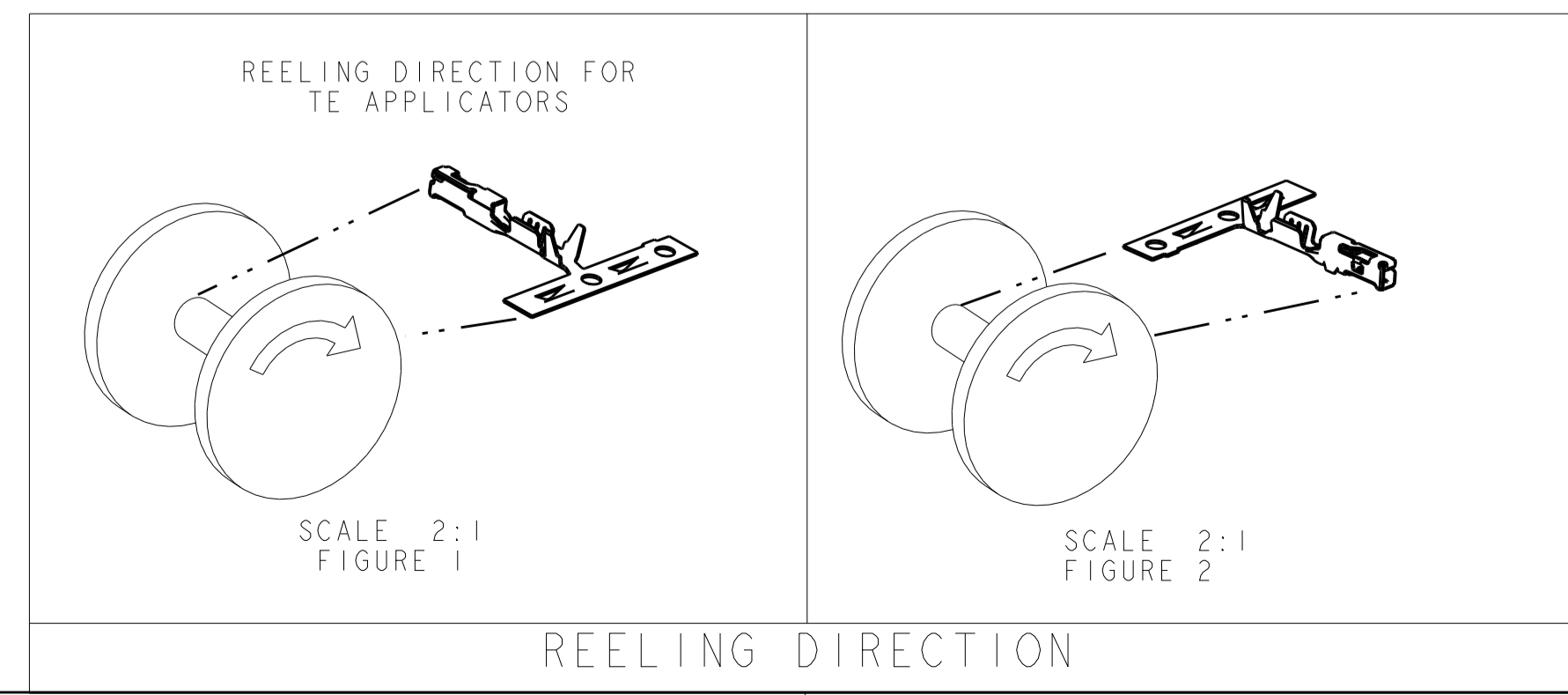

INSULATION DIAMETER	T	S	R	L	K	J	REELING DIRECTION	mm ²	AWG	PART NUMBER
1.10-1.40	2.38	1.40	2.40	1.70	0.80	1.85	FIGURE 2	0.35	22	2098762-8
0.85-1.05	2.09	0.85	1.82	1.46	0.65	1.50	FIGURE 2	0.13	26	2098762-7
2.06 MAX	3.09	1.78	2.94	2.43	1.00	1.96	FIGURE 2	0.75	18	2098762-6
1.50-1.85	3.09	1.78	2.94	2.23	0.80	1.82	FIGURE 2	0.35-0.50	20-22	2098762-5
1.10-1.40	2.38	1.40	2.40	1.70	0.80	1.85	FIGURE 1	0.35	22	2098762-4
0.85-1.05	2.09	0.85	1.82	1.46	0.65	1.50	FIGURE 1	0.13	26	2098762-3
2.06 MAX	3.09	1.78	2.94	2.43	1.00	1.96	FIGURE 1	0.75	18	2098762-2
1.50-1.85	3.09	1.78	2.94	2.23	0.80	1.82	FIGURE 1	0.35-0.50	20-22	2098762-1

THIS DRAWING IS A CONTROLLED DOCUMENT. DMN F KINSEY 04FEB2010
 CHK F KINSEY 04FEB2010
 APVD C SCHMID 04FEB2010

DIMENSIONS: mm
 TOLERANCES UNLESS OTHERWISE SPECIFIED:
 0 PLC ±
 1 PLC ±0.15
 2 PLC ±
 3 PLC ±
 4 PLC ±
 ANGLES ±

MATERIAL: FINISH:

PRODUCT SPEC:

APPLICATION SPEC:

WEIGHT: 114-13183

CUSTOMER DRAWING

SCALE 15:1 SHEET 1 OF 1 REV B

STE TE Connectivity
 CONTACT, FEMALE, 0.64mm
 CuNiSi, BOTTOM ORIENTATION
 Sn PLATE

SIZE: A100779 CAGE CODE: 2098762 DRAWING NO: 114-13183