

Series 15133

Depluggable PCB Mount Terminal Blocks

SPECIFICATIONS

Rating: 20A, 300V

Center Spacing: .375" or 3/8" (9.52 mm)

Wire Range: #12-22 AWG

PC Board: For soldering to PCB (.00015" tin over copper flash)

Material: Black, UL Rated 94V0 Thermoplastic

Screws: #6-32 Zinc plated steel SEMS

Torque Rating: 12 in-lb

Terminals: 15133-XX-10-X – Tin or gold plated brass
15133-XX-20-X – Nickel or gold plated copper alloy plug terminal, tin or gold plated female terminal

Operating Temperature: 221°F (105°C)

Agency Information: UL/CSA; CE Certified

The 15133 is a series of input/output circuit board connectors. Available in a 1-piece or 2-piece design, they stack side-by-side with self-aligning housings to prevent incorrect mating. Both designs feature an integral, living hinge cover that saves the labor of attaching a separate cover. The cover provides a dead front for prevention of electrical accidents, yet it also has test probe holes for easy circuit testing.

The 1-piece design is for applications not requiring unplugging the connector. It solders to the printed circuit board. Molded stand-offs ensure good solderability.

The 2-piece design enables quick connect and disconnect of several circuits at once. It allows fast board changing in the field without shutting down the entire system. The bottom section of the connector solders to the board. Male contacts are shrouded while the female has stand-offs; both are molded into the block. The top section of the connector plugs into the bottom section.



15133-06-20-T

15133-XX-10-X

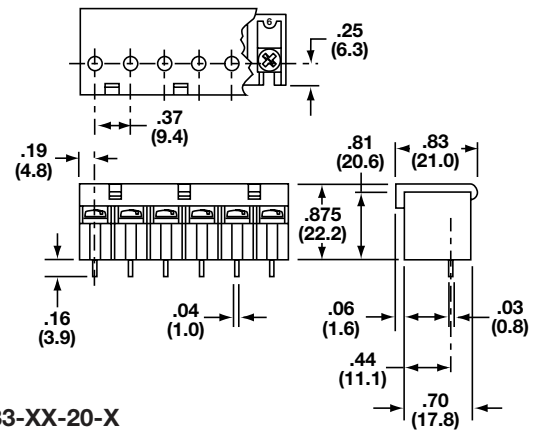

15133-XX-20-X

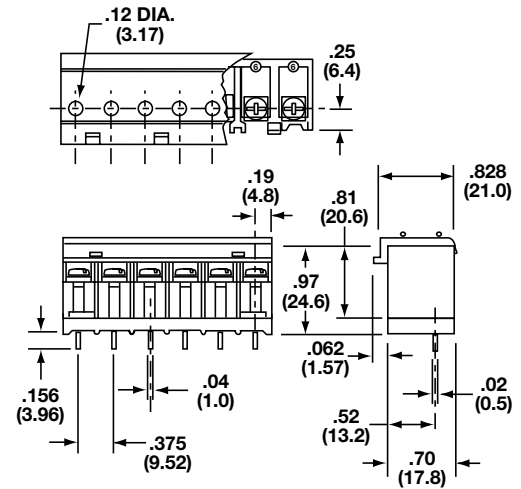

Part Numbering System

Inches (Millimeters)

Series



Poles



02 to 10

Style



1 - One piece
2 - Two piece

Mounting



0 - No mtg. holes

Terminal Plating



T - Tin
G - Gold*

* Consult Factory