

SPECIFICATION AND PERFORMANCE

Series	125X-78X00	File	125-Series_SPEC_3	Date	2020/04/17
--------	------------	------	-------------------	------	------------

Scope:

This specification covers the requirements for product performance, test methods and quality assurance provisions of

P/ N	Descriptions
125A-78A00	MXM 230P Connector, STD, 7.8H, Gold Flash, Black, Reel
125A-78C00	MXM 230P Connector, STD, 7.8H, 5u", Black, Reel
125A-78D00	MXM 230P Connector, STD, 7.8H, 10u", Black, Reel
125B-78A00	MXM 314P Connector, STD, 7.8H, Gold Flash, Black, Reel
125B-78C00	MXM 314P Connector, STD, 7.8H, 5u", Black, Reel

Performance and Descriptions:

The product is designed to meet the electrical, mechanical and environmental performance requirements specification. Unless otherwise specified, all tests are performed at ambient environmental conditions.

RoHS:

All material in according with the RoHS environment related substances list controlled.

MATERIAL AND FINISH		
INSULATOR	Material	LCP, UL94V-0, Black
CONTACT	Material	Copper Alloy
	Plating	Au Plated 5μ" MIN. Ni Under Plated 60μ" MIN.
SHELL OR COVER	Material	Copper Alloy
	Plating	Ni Under Plated 60μ" MIN. Matte Tin 80μ" MIN.
RATING	Current Rating: 0.5A (per pin) Voltage Rating: 50V DC (per pin) Contact Resistance: 40mΩ max (Initial) Withstanding Voltage: 250V AC Operating Temperature: -40~ +85°C	

ELECTRICAL		
Item	Requirement	Test Condition
Low Level Contact	Initial: 40mΩ max.	EIA-364-23B

Resistance	Final: 50mΩ max or Δ 20mΩ max, whichever is less, for measurements after other tests	Specify which option used. Do not used option 4. [Reference to Figure 1]
Dielectric Withstanding Voltage	No evidence of flash over or insulation shall take place. Current leakage: 1mA Max.	EIA-364-20B Method B on one pair of upper adjacent contacts and on one pair of lower adjacent contacts. Apply 250V AC (50Hz) for 1 minute.
Insulation Resistance	Initial: 250MΩ Min. Final: 50MΩ Min.	EIA-364-21C Impressed voltage 500V DC. Test between adjacent circuits of unmated connector.
Temperature Rise	30°C Max change allowed at rated current.	EIA-364-70 Method 2 Mate connectors, measure the temperature rise at rated current after 0.5A/Power contact. The temperature rise above ambient shall not exceed 30°C the ambient condition is still air at 25°C.

MECHANICAL

Item	Requirement	Test Condition
Mating/Unmating Force	30 cycles 125A-78C00(230P) Mating Force: 13N Max. Unmating Force: 16N Max. 125B-78C00(314P) Mating Force: 25N Max. Unmating Force: 28N Max.	EIA-364-13C Card mating/unmating sequence: a) Insert the card at the angle specified by the manufacture. b) Rotate the card into position. c) Reverse the installation sequence to unmating. Operation Speed: 25.4mm per minute. Measure the force required to mate/unmate connector. [Reference to Figure 2]
Durability	30 cycles No evidence of physical damage.	EIA-364-09 The sample should be mounted in the tester and fully mate and unmated the rate of 25.4mm per minute.
Durability (Preconditioning)	5 cycles No evidence of physical damage.	EIA-364-09 The sample should be mounted in the tester and fully mate and unmated the rate of 25.4mm per minute.
Vibration	No electrical discontinuity greater than 1 μ sec shall occur. No evidence of physical damage.	EIA-364-28 Test condition VII, Test condition D With a 40x40mm block of 100 grams fastened and center of Module.
Mechanical Shock	No electrical discontinuity greater than 1 μ sec shall occur. No evidence of physical	EIA-364-27B Test condition A With a 40x40mm block of 100 grams fastened and center of Module.

	damage.	
Solder Peg Retention Force	5N/Pos. (Min.)	Place a connector on the push-pull machine, then apply a force on a contact head and push the latch to the opposite direction of the latch spring insertion at the speed of 25±3mm/min. Measure the force when the latch spring dislodges from insulator.
Contact Retention Force	1N/Pos. (Min.)	Place a connector on the push-pull machine, the apply a force on a contact head and push the contact to the opposite direction of the contact insertion at the speed of 25±3mm/min. Measure the force when the contact dislodges from insulator.

ENVIRONMENTAL

Item	Requirement	Test Condition
Humidity Temperature Cycle	No evidence of physical damage.	EIA-364-31, method III Mated Connector. Initial measurement, cold shock and vibration. Cycle the connector between 25±3 °C at 80±3% RH and 65±3 °C at 50±3% RH. Ramp times should be 0.5 hour and dwell times should be 1.0 hour. Dwell times start when the temperature and humidity have stabilized within the specified levels. Perform 24 such cycles.
Thermal Shock	No evidence of physical damage.	EIA-364-32, test condition I Mated Connector, 10 cycles
Temperature Life	No evidence of physical damage.	EIA-364-17, method A Mated Connector, 105°C, 120 hours
Temperature Life (Preconditioning)	No evidence of physical damage.	EIA-364-17, method A Mated Connector, 105°C, 92 hours
Reseating	No evidence of physical damage.	Manually mating/unmating the connector. Perform 3 such cycles.

SOLDER ABILITY

Item	Requirement	Test Condition
Reflow Soldering Heat Resistance	No evidence of physical damage.	Pre-heat: 150~215°C, 30~120 sec. Reflow: 230°C MIN, 40 sec Min. Peak temp:260°C Max, 10 sec Max. [Reference to Figure 3]
Solder Ability	Solder coverage 95% Min.	EIA-364-52 Solder 5±0.5 seconds. Solder temperature:245±5°C

Test Item		Test Group									
		A	B	C	D	E	F	G	H	I	J
1	Examination of Product	1	1,7	1,5,8	1,5	1	1,7	1,10	1,8	1,3	1,3
2	Low Level Contact Resistance		2,6	2,5,7	2,4			2,5,7,9	2,5,7		
3	Dielectric Withstanding Voltage						2,5				
4	Insulation Resistance						3,6				
5	Temperature Rise	2									
6	Mating/Unmating Force		3,5								
7	Durability		4								
8	Durability(Preconditioning)			3				3	3		
9	Vibration			6							
10	Mechanical Shock				3						
11	Solder Peg Retention Force					2					
12	Contact Retention Force					3					
13	Humidity Temperature Cycling						4	6			
14	Thermal Shock							4			
15	Temperature Life								4		
16	Temperature Life (Preconditioning)			4							
17	Reseating							8	6		
18	Reflow Soldering Heat Resistance									2	
19	Solder Ability										2
Quantities of Samples		5	5	5	5	5	5	5	5	5	5

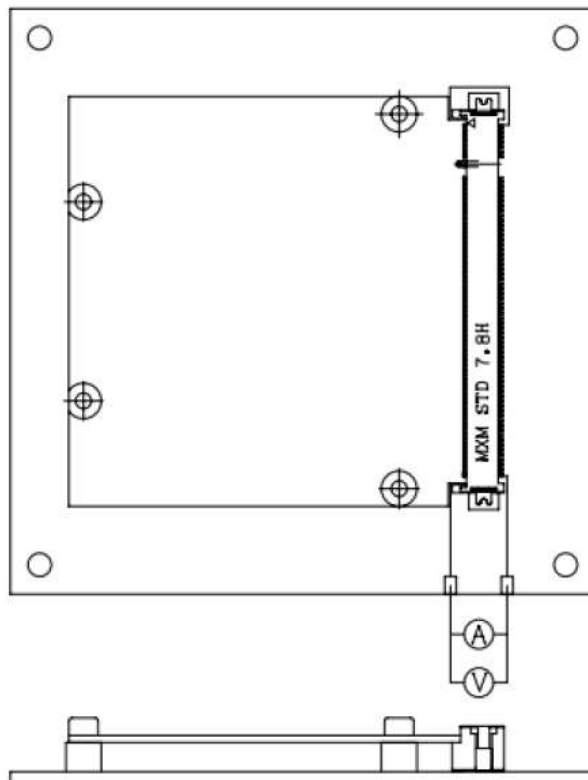
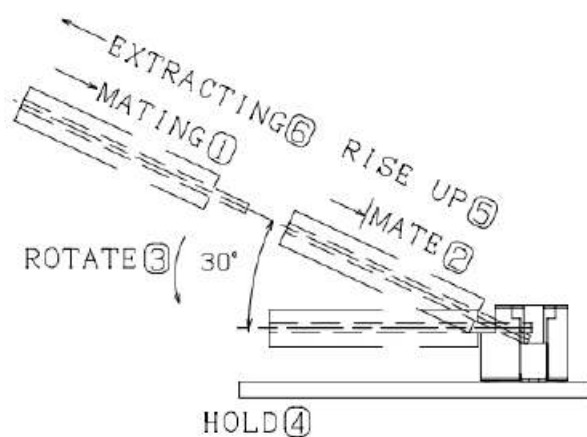

Figure 1



HOW TO MATE AND UNMATE

MATE ① - ④

UNMATE ⑤ - ⑥

Figure 2

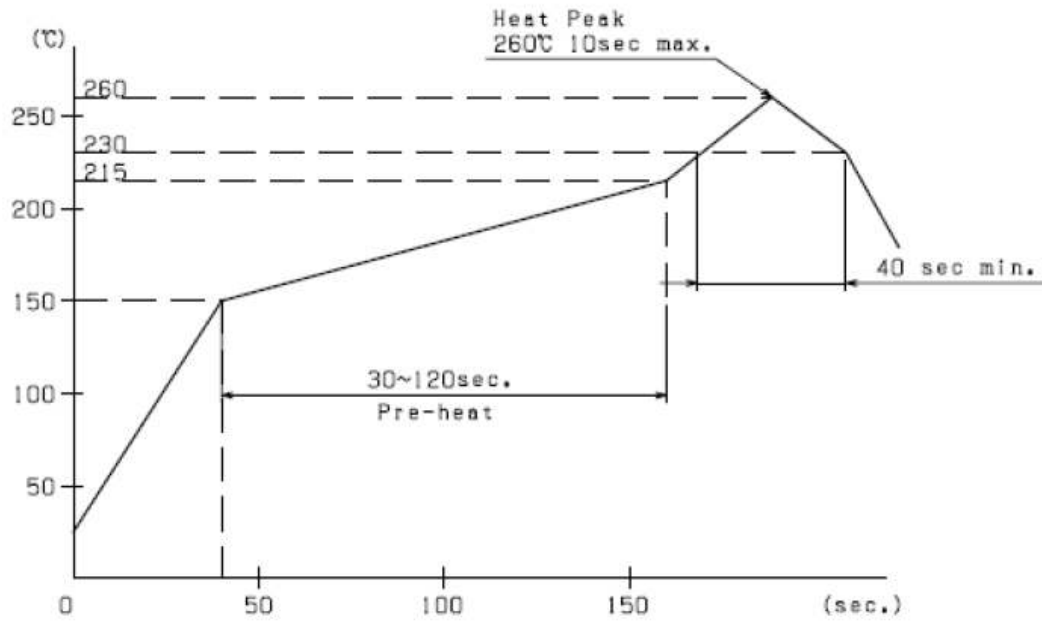

Figure 3