

"SAN ACE 127" Fan (127mm sq. x 38mm thick)

Jiro Watanabe

Yoshikazu Ooya

Munenori Takakuwa

1. Introduction

Various types of information equipment are increasing their amounts of heat generated through the high-density mounting of components inside the equipment due to their increasingly high functions and small sizes. Fan motors used for cooling the equipment are required to achieve higher cooling capacity. It is also noted that these equipment items are spreading quickly not only to offices but to households as well, resulting in an increasing demand for low-noise models.

These items, which are becoming quicker and larger in capacity, are receiving increasingly diversified requirements of customers for cooling fan motors.

To meet these requirements, Sanyo Denki has developed "SAN ACE 127"(127mm sq. x 38mm thick BLDC fan), which achieves large air volume, low noise, and high reliability, as a new series of fans.

This paper presents an overview and the features of these products.

2. Background of development

Cooling fan motors used in servers, communications units and other equipment are required to achieve high air volumes. They are required to be small in size and to achieve an air volume of at least $3.8\text{m}^3/\text{min}$.

Sanyo Denki offers a line of cooling fans of this class measuring 120mm sq. x 38mm thick. However, this size is not large enough to produce an air volume of $3.8\text{m}^3/\text{min}$ with leeway. On the other hand, fans 140mm sq. x 38mm thick, which is one size larger, can easily produce an air volume of $3.8\text{m}^3/\text{min}$ but has the problem of being too big in outside dimensions.

To resolve these inconveniences, Sanyo Denki has developed a new fan series: "SAN ACE 127" (127mm sq. x 38mm thick BLDC fans).

3. Features and main characteristics of "SAN ACE 127"

[Fig.1](#) is an outside view of "SAN ACE 127."

"SAN ACE 127" incorporates a newly designed group of vanes and frame, and is designed to achieve a large air volume, high static pressure, low noise, and high reliability. The following is a list of features of this series of products.

- (1)Dimensions of the new series of fans: 127mm sq. x 38mm thick
- (2)Large air volume-high static pressure
- (3)Low noise
- (4)High reliabilit

3.1 Dimensional specifications

[Fig. 2](#) shows the dimensional specifications of "SAN ACE 127."

3.2 Characteristics

3.2.1 General characteristics

Table 1 shows the general characteristics of "SAN ACE 127."

The series comes with three different voltage ratings: 12, 24, and 48V. They have two different rated rotating speeds: H speed (2,950min⁻¹) and S speed (3,300min⁻¹).

3.2.2 Air volume–static pressure characteristics

[Fig. 3](#) shows the air volume–static pressure characteristics of a typical "SAN ACE 127" model.

Table 1 General characteristics of "SAN ACE 127"

Model No.*1	Rated voltage (V)	Operating voltage range (V)	Rated current (A)	Rated rotating speed (min ⁻¹)	Maximum air volume (m ³ /min)	Maximum static pressure (Pa)	Sound pressure level*2 (dB [A])	Mass (g)
109P1312H102 (109P1312H1021)	12	10.2 ~ 13.8	0.82	2950	3.8	98	45	350
109P1312S102 (109P1312S1021)		10.2 ~ 13.8	1.3	3300	4.2	117.6	47	
109P1324H102 (109P1324H1021)	24	20.4 ~ 27.6	0.41	2950	3.8	98	45	
109P1324S102 (109P1324S1021)		20.4 ~ 27.6	0.55	3300	4.2	117.6	47	
109P1348H102 (109P1348H1021)	48	40.8 ~ 55.2	0.2	2950	3.8	98	45	
109P1348S102 (109P1348S1021)		40.8 ~ 55.2	0.3	3300	4.2	117.6	47	

*1: The models in parentheses are ribless.

*2: The sound pressure level is measured 1m from the surface of the fan

3.2.3 Comparison of the air volume–static pressure characteristics

[Fig. 4](#) compares the air volume–static pressure characteristics of "SAN ACE 127" H speed and Sanyo Denki's 120mm sq. x 38mm thick H speed.

As shown in the diagram, "SAN ACE 127" (in solid lines) achieves a air volume approximately 30% larger and a static pressure approximately 50% higher than a typical fan 120mm sq. x 38mm thick (in dotted lines).

Next, [Fig. 5](#) compares the air volume–static pressure characteristics of "SAN ACE 127" H speed and Sanyo Denki's 140mm sq. x 38mm thick H speed.

As shown in the diagram, "SAN ACE 127" (in solid lines), despite dimensions 127mm sq. x 38mm thick, achieves characteristics comparable to those of a typical fan 140mm sq. x 38mm thick (in dotted lines), except for the air volume.

3.2.4 Load noise

[Fig. 6](#) shows a typical pattern of load noise characteristics of "SAN ACE 127." [Fig. 7](#) illustrates how to measure load noise.

3.3 Frame and vane shapes

The frame is shaped based on a Sanyo Denki fan 120mm sq. x 38mm thick. It differs greatly from traditional models in that it incorporates a completely circular shape for the intake side of the frame to reduce noise, and that its entire circumference is spherical in shape with an equal curvature.

The use of a spherical shape for the intake side of the frame is effective in reducing

the noise level. However, a square fan entails four flat surfaces in the inner side of the frame due to the outside shape, resulting in noise due to pressure changes and turbulence in those regions.

To resolve such inconveniences, the authors set the inner diameter of the frame to a small setting and made the entire circumference of the intake side an equally spherical shape.

As a result, the impeller has a reduced outside diameter, but the vane shape, installation angle, cross section shape and other parameters were newly designed to secure a good air volume.

4. Conclusion

This paper has so far presented part of the structure and performance of the newly developed "SAN ACE 127."

In the future, computers and various other items of information equipment are expected to become increasingly small-sized, more dense, with larger amounts of heat generated. Accordingly, cooling fan motors will be required to achieve higher performance.

Under these circumstances, the newly developed "SAN ACE 127," a product high in cooling performance, low in noise, and high in reliability, will meet increasingly diverse customer requirements for cooling fan motors.

Jiro Watanabe

Joined company 1978
Cooling Systems Division, Design Dept.
Worked on development and design of fan motors

Yoshikazu Ooya

Joined company 1995
Cooling Systems Division, Design Dept.
Worked on development and design of fan motors

Munenori Takakuwa

Joined company 1998
Cooling Systems Division, Design Dept.
Worked on development and design of fan motors



fig.1 Outside view of "SAN ACE 127"

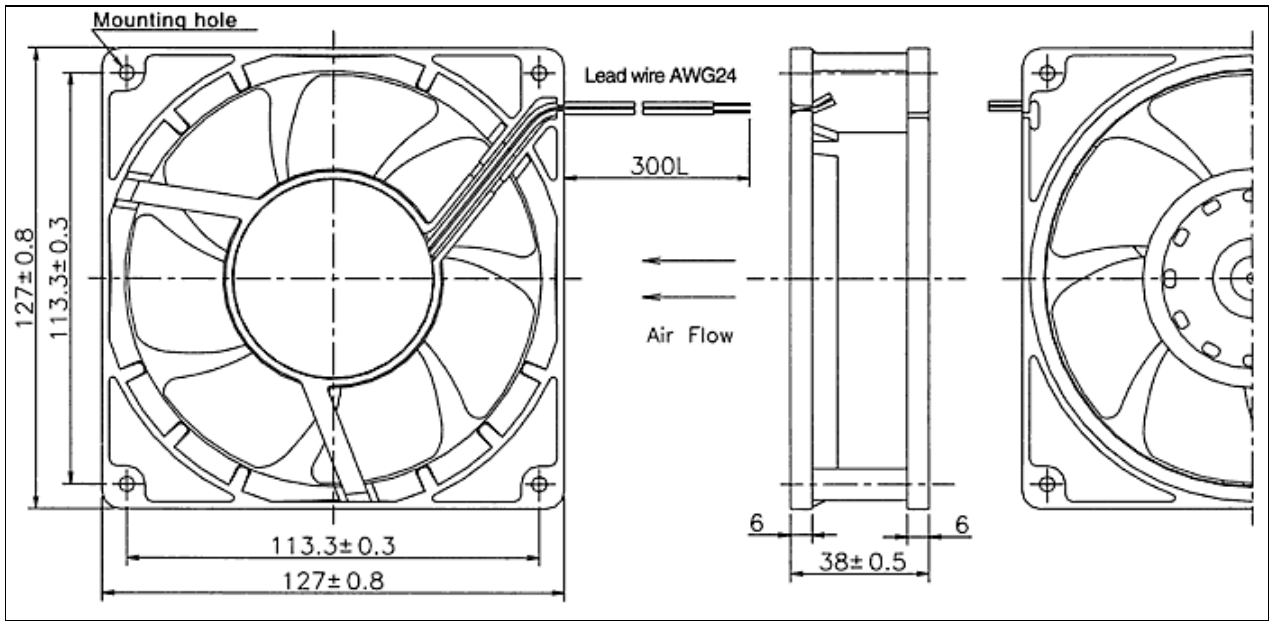

fig.2 Dimensional specifications of "SAN ACE 127"

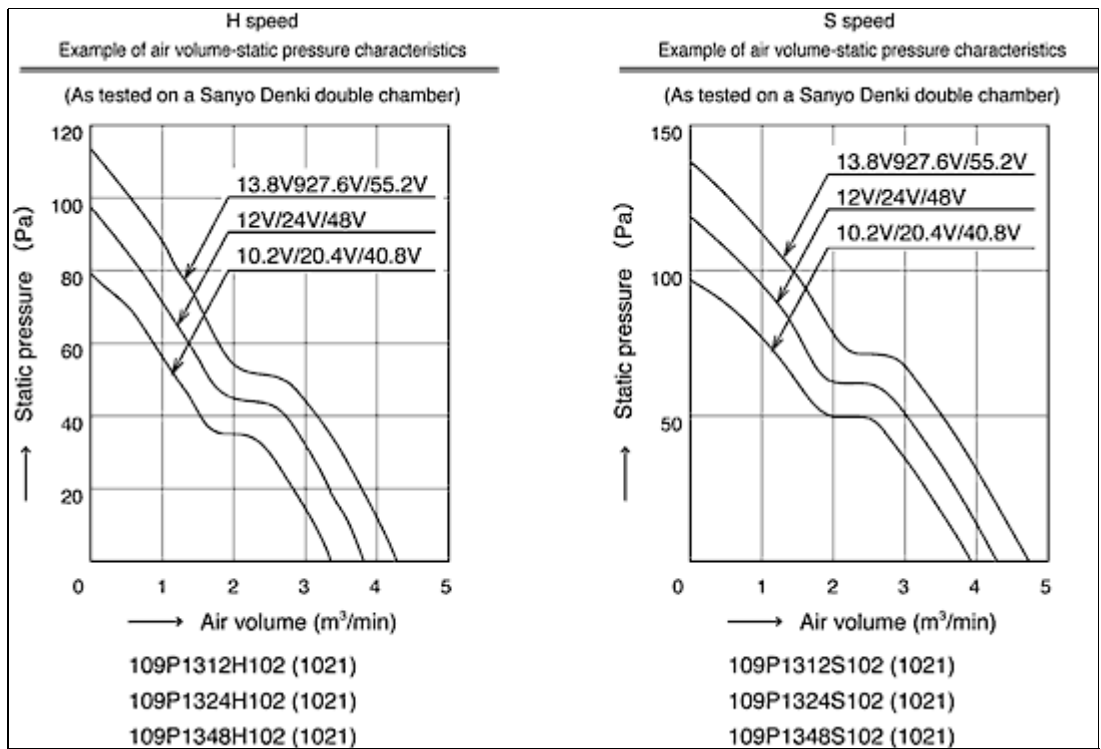

fig.3 Air volume-static pressure characteristics of "SAN ACE 127"

Example of
air volume-static pressure characteristics of different models compared

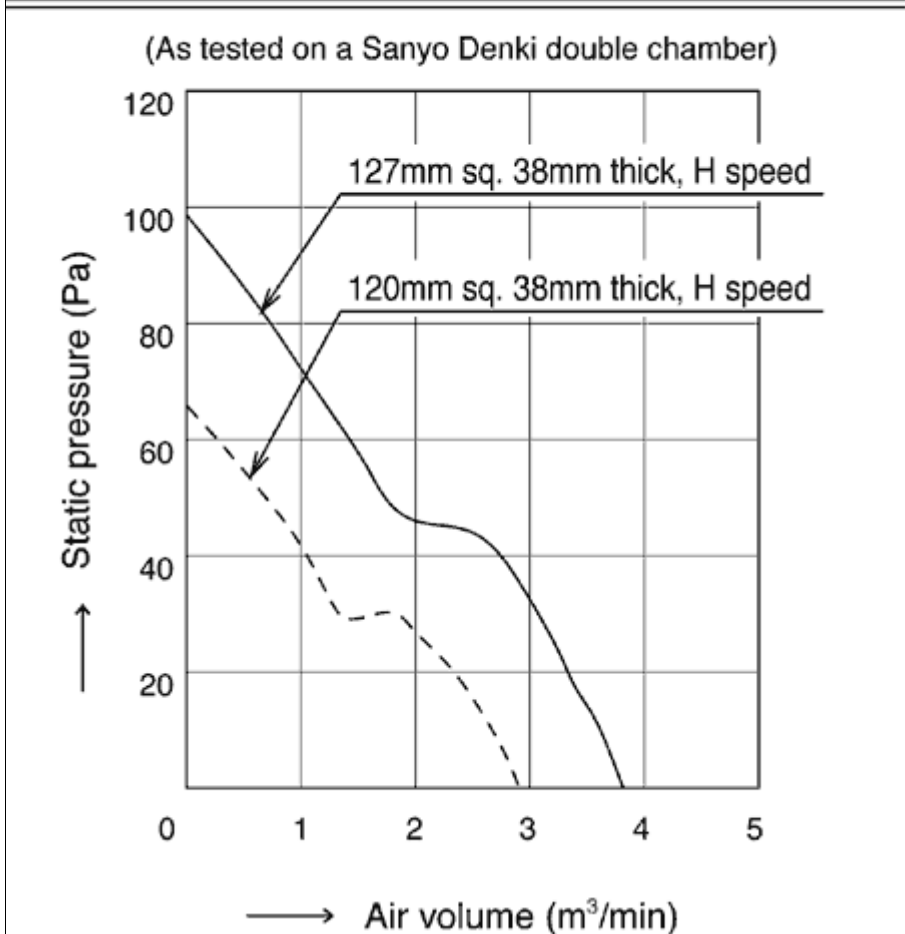

fig.4 Air volume-static pressure characteristics

Example of
air volume-static pressure characteristics of different models compared

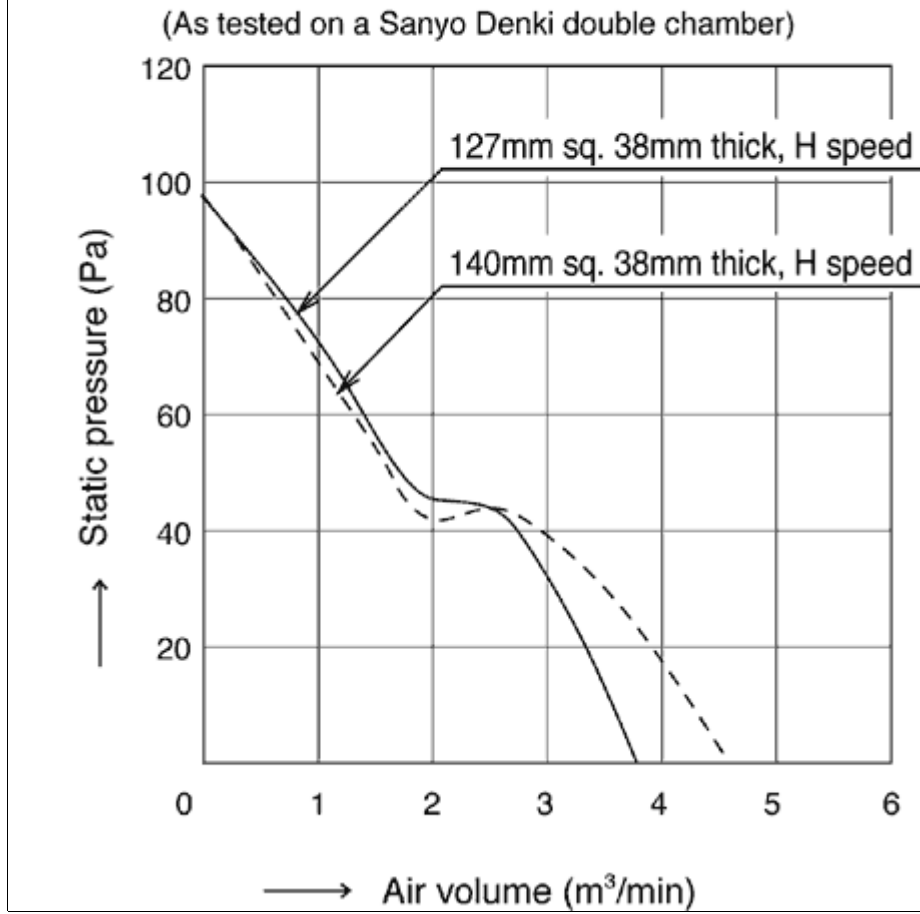

fig.5 Air volume-static pressure characteristics

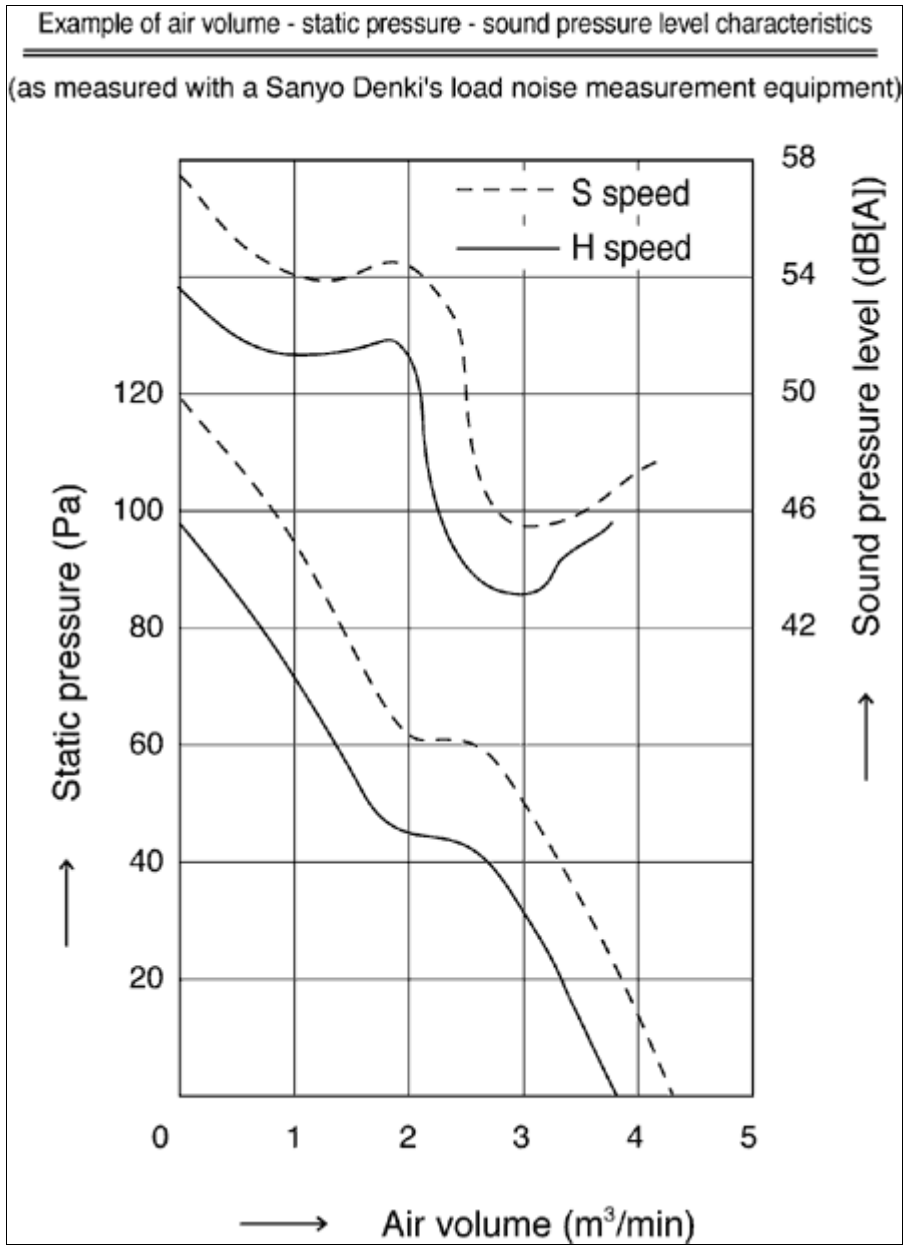

fig.6 Example of load noise characteristics of "SAN ACE 127"

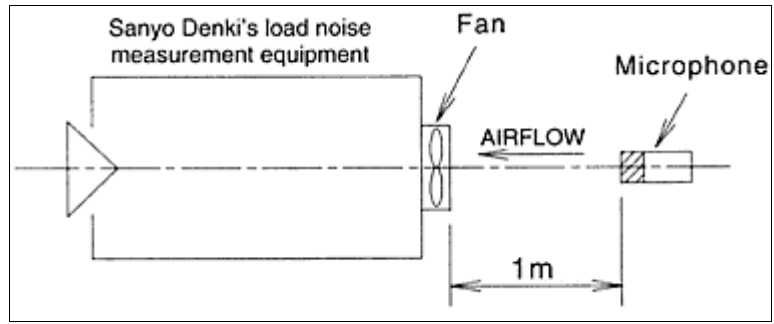

fig.7 Method of load noise measurement