



## Technical Data Sheet

### 0.39" Single Digit SMD Displays

#### ELSS-406SURWA/S530-A2/S290

#### Features

- Packaged in tape and reel for SMT manufacturing.
- Design flexibility (common cathode or anode).
- Categorized for luminous intensity.
- The thickness is thinner than traditional display.

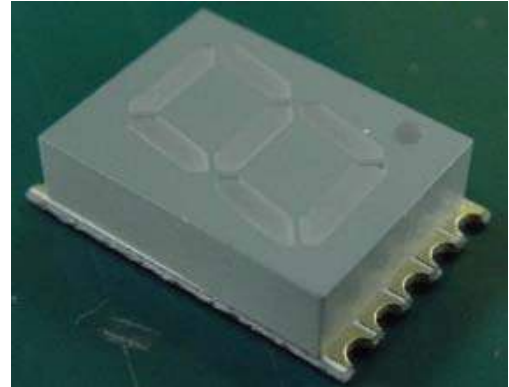

#### Descriptions

- The SMD type is much smaller than traditional type components, thus enabling smaller board size, higher packing density, reduced storage space and finally smaller equipment to be obtained.

#### Applications

- Suitable for indoor use.
- Audio system.
- Set top box.
- Game machine.
- Channel indicator of TV.

#### Device Selection Guide

Chip		Face Color
Material	Emitted Color	
AlGaInP	Hyper Red	Gray

**Package Dimensions**

**Land Pattern(Recommend)**

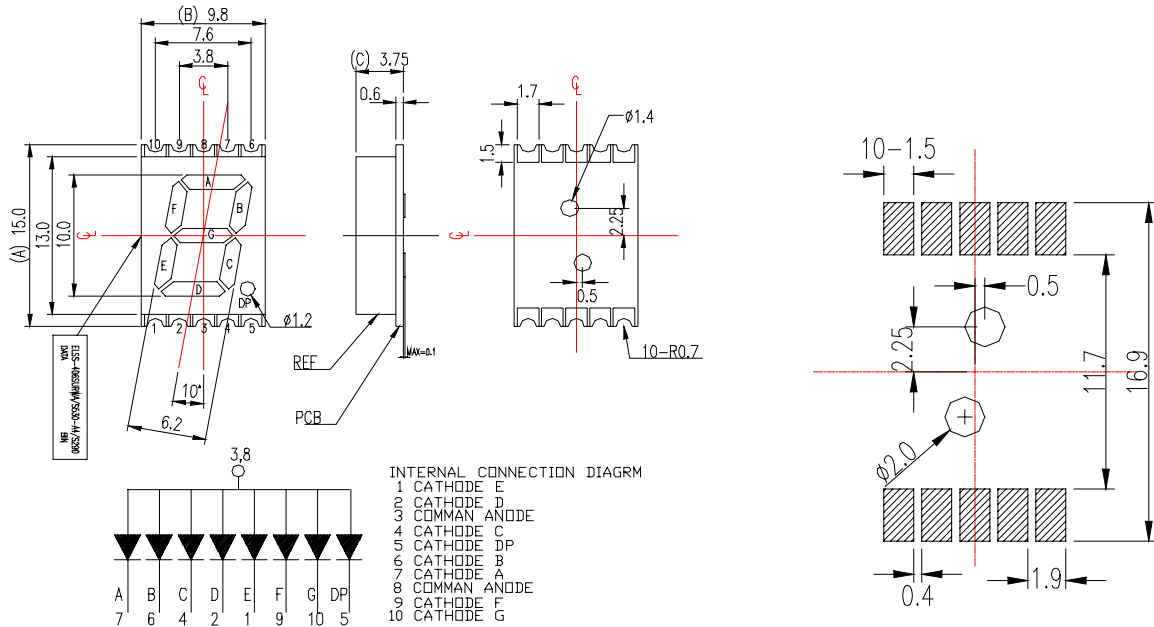

**Notes:**

- All dimensions are in millimeters, tolerance is 0.25mm unless otherwise noted.
- Above specification may be changed without notice. Supplier will reserve authority on material change for above specification.

**Absolute Maximum Ratings (Ta=25°C)**

Parameter	Symbol	Rating	Units
Forward Current	I <sub>F</sub>	25	mA
Pulse Forward Current <sup>*1</sup>	I <sub>FP</sub>	160	mA
Operating Temperature	T <sub>opr</sub>	-40 ~ +105	°C
Storage Temperature	T <sub>stg</sub>	-40 ~ +105	°C
Soldering Temperature <sup>*2</sup>	T <sub>sol</sub>	260	°C
Power Dissipation	P <sub>d</sub>	60	mW
Reverse Voltage	V <sub>R</sub>	5	V

**Notes:** \*1:I<sub>FP</sub> Conditions--Pulse Width ≤ 10msec and Duty ≤ 1/10.

\*2:Soldering time ≤ 5 seconds.

**Electro-Optical Characteristics (Ta=25°C)**

Parameter		Symbol	Condition	Min.	Typ.	Max.	Units
Forward Voltage		$V_F$	$I_F=20mA$	--	2.0	2.4	V
Reverse Current		$I_R$	$V_R=5V$	--	--	10	$\mu A$
Luminous Intensity	Per segment	$I_V$	$I_F=2mA$	----	1.14	--	mcd
			$I_F=10mA$	2.8	7.22		
	Per decimal point		$I_F=2mA$	----	0.34	--	
			$I_F=10mA$	-----	2.17		
Peak Wavelength		$\lambda_p$	$I_F=20mA$	--	632	--	nm
Dominant Wavelength		$\lambda_d$	$I_F=20mA$	--	624	--	nm
Spectrum Radiation Bandwidth		$\Delta \lambda$	$I_F=20mA$	--	20	--	nm

**Chromaticity Coordinates Specifications for Bin Grading (Unit: mcd)**

Rank	Min.	Max.	Rank	Min.	Max.
M	2.8	4.5	Q	7.8	12.5
N	4.0	6.4	R	11.0	17.6
P	5.6	8.9	--	--	--

**Typical Electro-Optical Characteristics Curves**

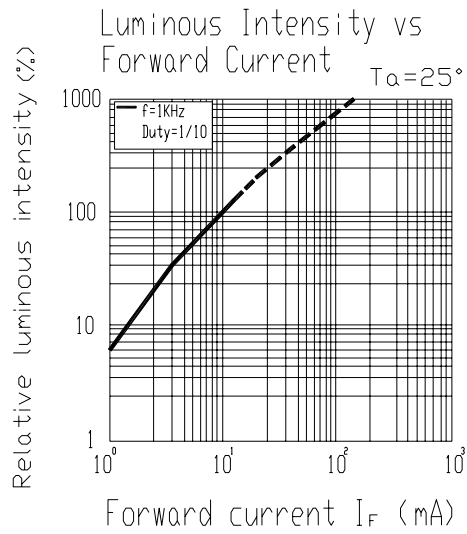
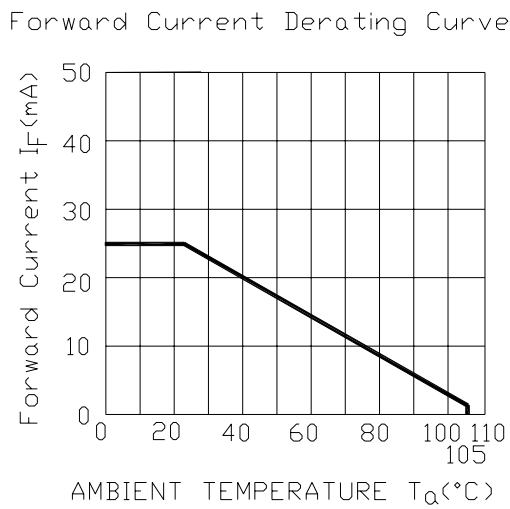
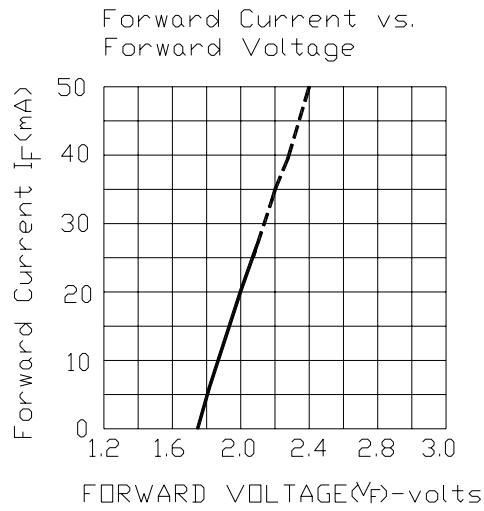
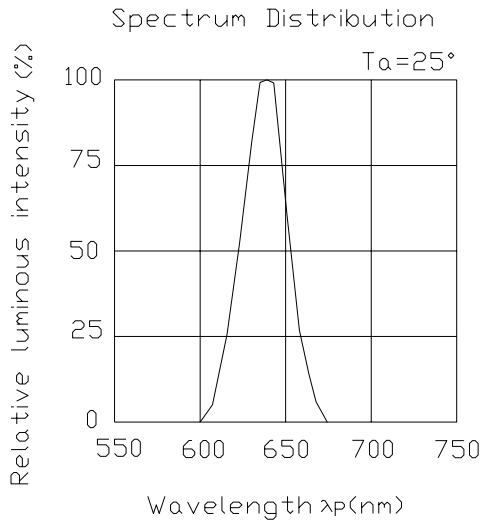

**■ Soldering heat reliability ( DIP ) :**

Please refer to the following figure :

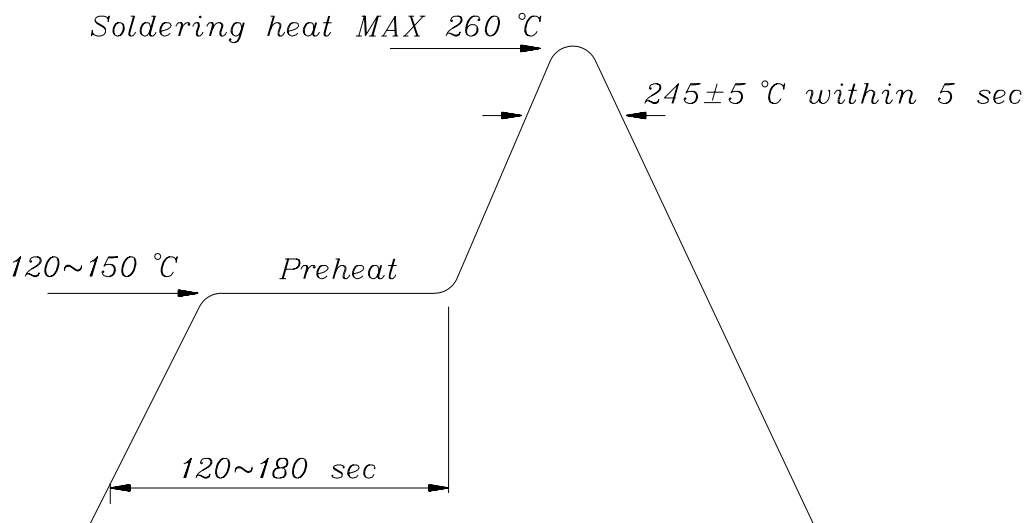
**■ Soldering Iron :**

Basic spec is  $\leq 5$  sec when 260°C. If temperature is higher, time should be shorter (+10°C → -1sec). Power dissipation of iron should be smaller than 15 W , and temperature should be controllable. Surface temperature of the device should be under 230 °C .

**■ Rework :**

1. Customer must finish rework within 5 sec under 260°C .
2. The head of iron can not touch copper foil.

■ **Reflow Temp. / Time :**

Reflow Temp./Time:

