

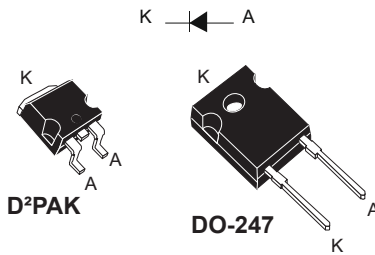

Automotive 600 V, 30 A low drop ultrafast diode



Features

- AEC-Q101 qualified 
- Ultrafast recovery
- Low conduction losses
- High surge capability
- Low leakage current
- High junction temperature
- V_{RRM} guaranteed from -40 to +175 °C
- ECOPACK2 compliant (DO-247)

Applications

- OBC in EV-HEV
- Charging station
- Output rectification
- PFC topologies

Description

The STTH30L06-Y is an ultrafast recovery power rectifier dedicated to energy efficiency housed in DO-247 and D²PAK.

The STTH30L06-Y is especially designed for PFC boost function in Automotive applications.

Product status link	
STTH30L06-Y	
Product summary	
$I_{F(AV)}$	30 A
V_{RRM}	600 V
V_F (typ.)	1.10 V
t_{rr} (max.)	65 ns
T_j (max.)	175 °C

1 Characteristics

Table 1. Absolute ratings (limiting values at 25 °C, unless otherwise specified)

Symbol	Parameter	Value	Unit
V_{RRM}	Repetitive peak reverse voltage ($T_j = -40\text{ °C}$ to $+175\text{ °C}$)	600	V
$I_{F(RMS)}$	Forward rms current	50	A
$I_{F(AV)}$	Average forward current $\delta = 0.5$, square wave	$T_c = 125\text{ °C}$ 30	A
I_{FSM}	Surge non repetitive forward current	$t_p = 10\text{ ms}$ sinusoidal 300	A
T_{stg}	Storage temperature range	-65 to +175	°C
T_j	Operating junction temperature range	-40 to +175	°C

Table 2. Thermal resistance parameter

Symbol	Parameter	Max. value	Unit
$R_{th(j-c)}$	Junction to case	1.1	°C/W

For more information, please refer to the following application note :

- **AN5088** : Rectifiers thermal management, handling and mounting recommendations

Table 3. Static electrical characteristics

Symbol	Parameter	Test conditions	Min.	Typ.	Max.	Unit	
$I_R^{(1)}$	Reverse leakage current	$T_j = 25\text{ °C}$	$V_R = V_{RRM}$	-		25	μA
		$T_j = 150\text{ °C}$		-	80	800	
$V_F^{(2)}$	Forward voltage drop	$T_j = 25\text{ °C}$	$I_F = 30\text{ A}$	-		1.55	V
		$T_j = 150\text{ °C}$		-	1.0	1.25	

1. Pulse test: $t_p = 5\text{ ms}$, $\delta < 2\%$

2. Pulse test: $t_p = 380\text{ }\mu\text{s}$, $\delta < 2\%$

To evaluate the conduction losses, use the following equation:

$$P = 0.95 \times I_{F(AV)} + 0.010 \times I_{F(RMS)}^2$$

For more information, please refer to the following application notes related to the power losses :

- **AN604**: Calculation of conduction losses in a power rectifier
- **AN4021**: Calculation of reverse losses on a power diode
- **AN5028**: Calculation of turn-off power losses generated by an ultrafast diode

Table 4. Dynamic characteristics ($T_j = 25\text{ °C}$ unless otherwise specified)

Symbol	Parameters	Test conditions	Min.	Typ.	Max.	Unit
t_{rr}	Reverse recovery time	$I_F = 0.5\text{ A}, I_R = 1\text{ A}, I_{RR} = 0.25\text{ A}$	-		65	ns
		$I_F = 1\text{ A}, V_R = 30\text{ V}, dI_F/dt = 50\text{ A}/\mu\text{s}$	-	65	90	
I_{RM}	Reverse recovery current	$I_F = 30\text{ A}, V_R = 400\text{ V}, dI_F/dt = 100\text{ A}/\mu\text{s}$	-	11.5	16	A
t_{fr}	Forward recovery time	$I_F = 30\text{ A}, dI_F/dt = 100\text{ A}/\mu\text{s}, V_{FR} = 1.1 V_{F(max)}$	-		500	ns
V_{FP}	Forward recovery voltage	$I_F = 30\text{ A}, dI_F/dt = 100\text{ A}/\mu\text{s}, V_{FR} = 1.1 V_{F(max)}$	-	2.5		V

1.1 Characteristics (curves)

Figure 1. Conduction losses versus average forward current (square waveform)

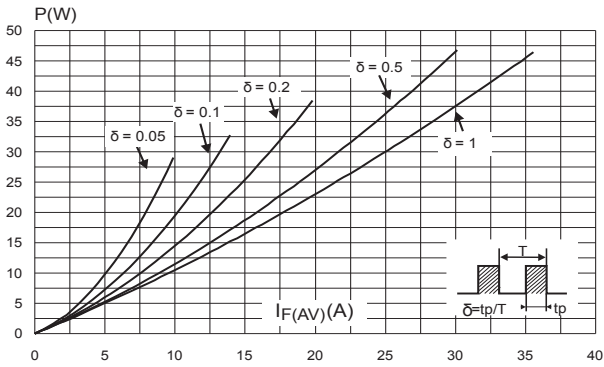

Figure 2. Conduction losses versus average forward current (sinusoidal waveform)

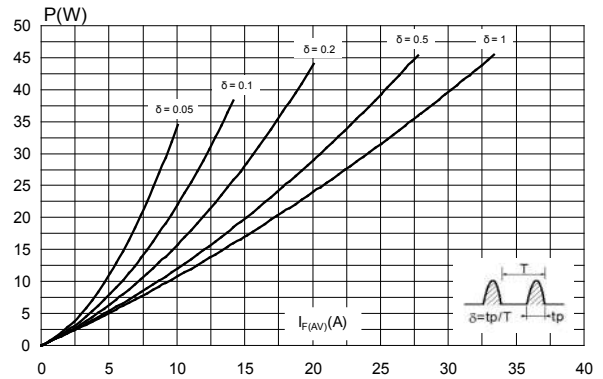

Figure 3. Forward voltage drop versus forward current

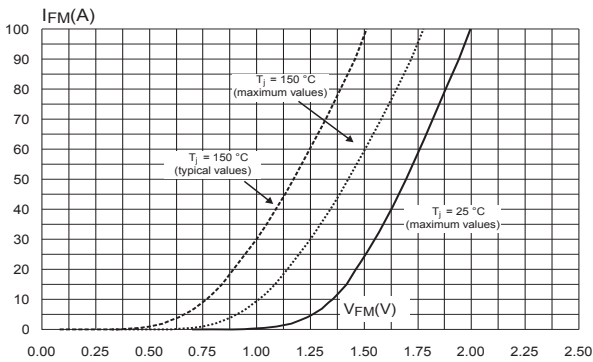

Figure 4. Relative variation of thermal impedance junction to case versus pulse duration

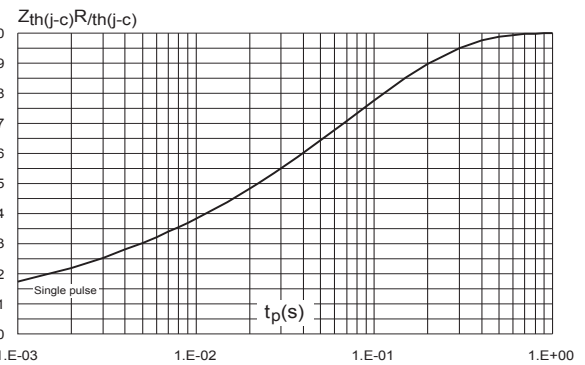

Figure 5. Peak reverse recovery current versus di_F/dt (typical values)

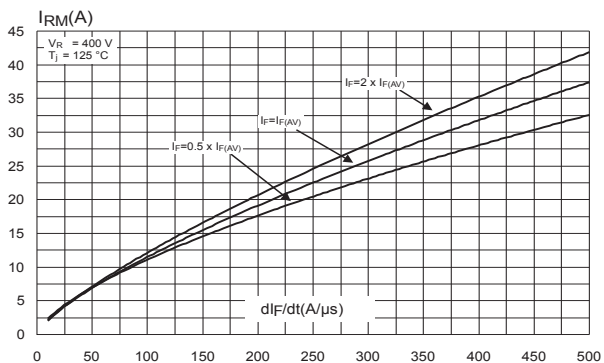

Figure 6. Reverse recovery time versus di_F/dt (typical values)

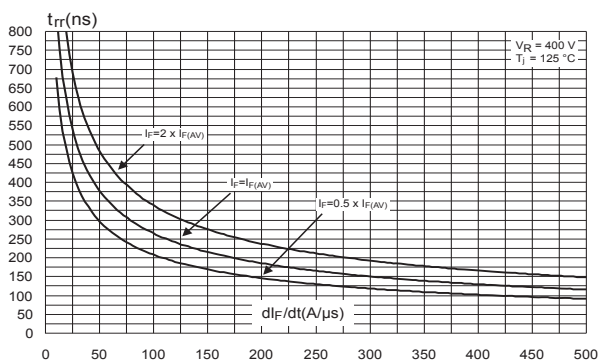

Figure 7. Reverse recovery charges versus di_F/dt (typical values)

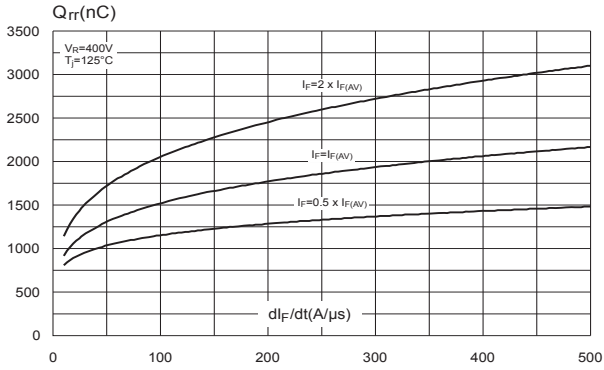

Figure 8. Reverse recovery softness factor versus di_F/dt (typical values)

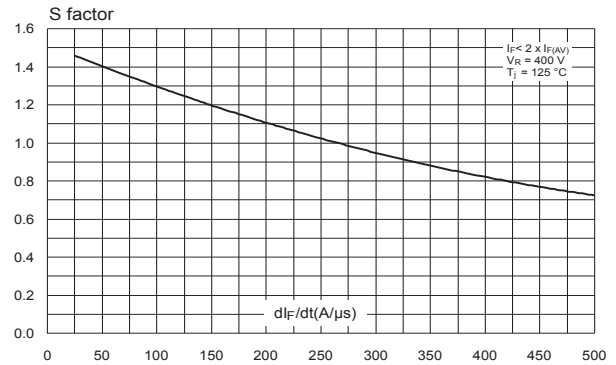

Figure 9. Relative variations of dynamic parameters versus junction temperature

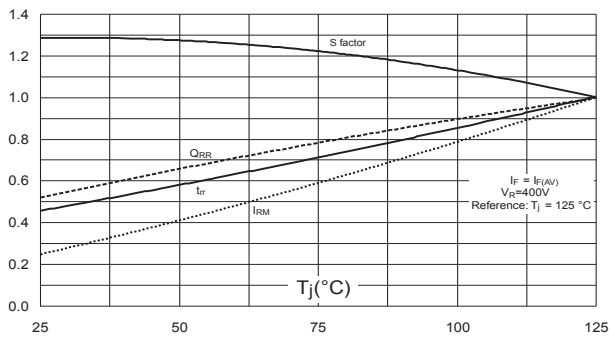

Figure 10. Transient peak forward voltage versus di_F/dt (typical values)

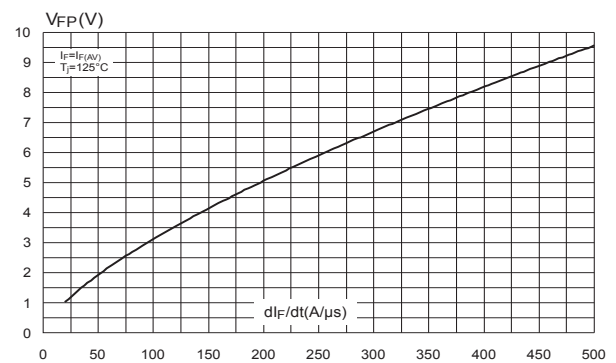

Figure 11. Forward recovery time versus di_F/dt (typical values)

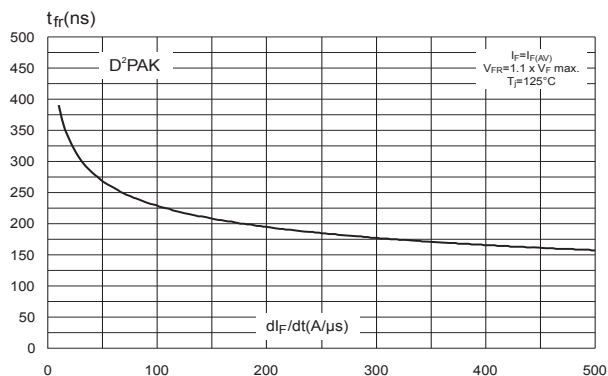

Figure 12. Junction capacitance versus reverse voltage applied (typical values)

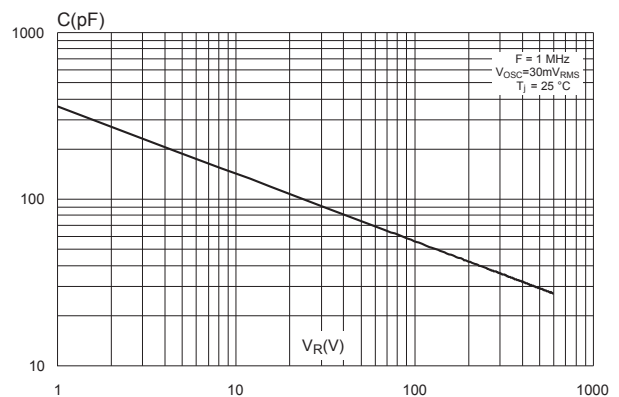
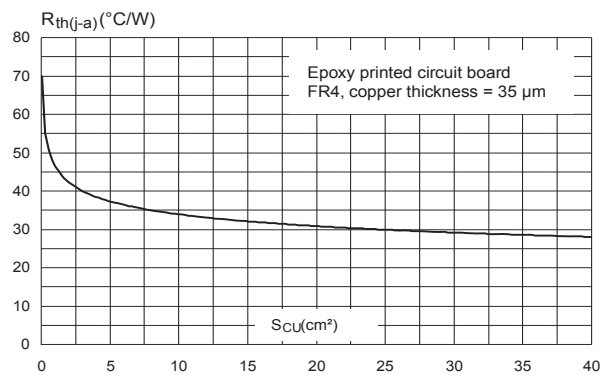

Figure 13. Thermal resistance junction to ambient versus copper surface under each lead (typical values)



2 Package information

In order to meet environmental requirements, ST offers these devices in different grades of **ECOPACK** packages, depending on their level of environmental compliance. ECOPACK specifications, grade definitions and product status are available at: www.st.com. ECOPACK is an ST trademark.

2.1 D²PAK package information

- Epoxy meets UL94, V0.
- Cooling method: by conduction (C)

Figure 14. D²PAK package outline

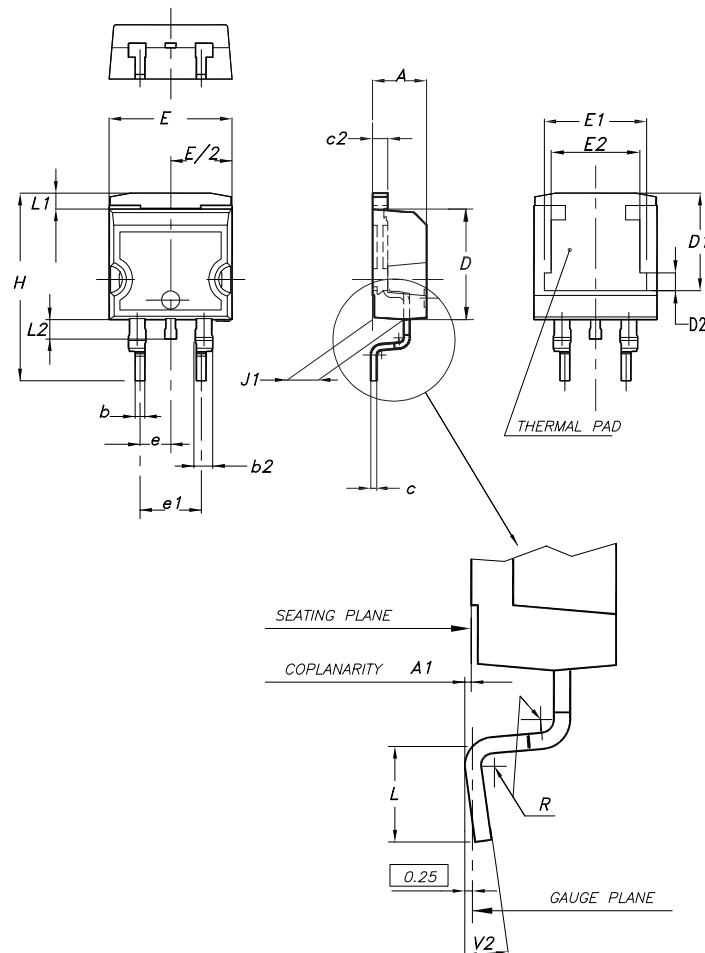

Note: This package drawing may slightly differ from the physical package. However, all the specified dimensions are guaranteed.

Table 5. D²PAK package mechanical data

Ref.	Dimensions					
	Millimeters			Inches (for reference only)		
	Min.	Typ.	Max.	Min.	Typ.	Max.
A	4.40		4.60	0.173		0.181
A1	0.03		0.23	0.001		0.009
b	0.70		0.93	0.028		0.037
b2	1.14		1.70	0.045		0.067
c	0.45		0.60	0.018		0.024
c2	1.23		1.36	0.048		0.053
D	8.95		9.35	0.352		0.368
D1	7.50	7.75	8.00	0.295	0.305	0.315
D2	1.10	1.30	1.50	0.043	0.051	0.060
E	10.00		10.40	0.394		0.409
E1	8.30	8.50	8.70	0.335	0.343	0.346
E2	6.85	7.05	7.25	0.266	0.278	0.282
e		2.54			0.100	
e1	4.88		5.28	0.190		0.205
H	15.00		15.85	0.591		0.624
J1	2.49		2.69	0.097		0.106
L	2.29		2.79	0.090		0.110
L1	1.27		1.40	0.049		0.055
L2	1.30		1.75	0.050		0.069
R		0.40			0.015	
V2	0°		8°	0°		8°

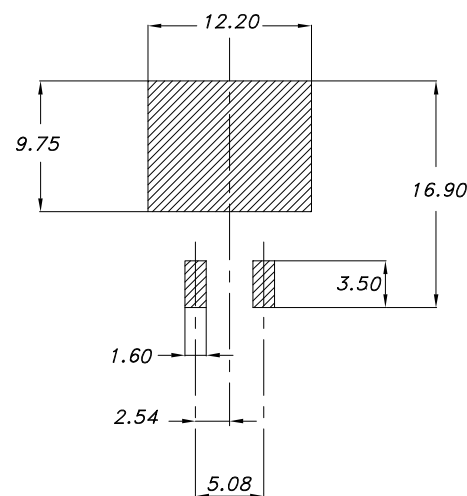
Figure 15. D²PAK recommended footprint (dimensions are in mm)

Footprint_26

2.2 DO-247 package information

- Epoxy meets UL94, V0
- Cooling method: by conduction (C)
- Recommended torque value: 0.8 N·m
- Maximum torque value: 1.0 N·m

Figure 16. DO-247 package outline

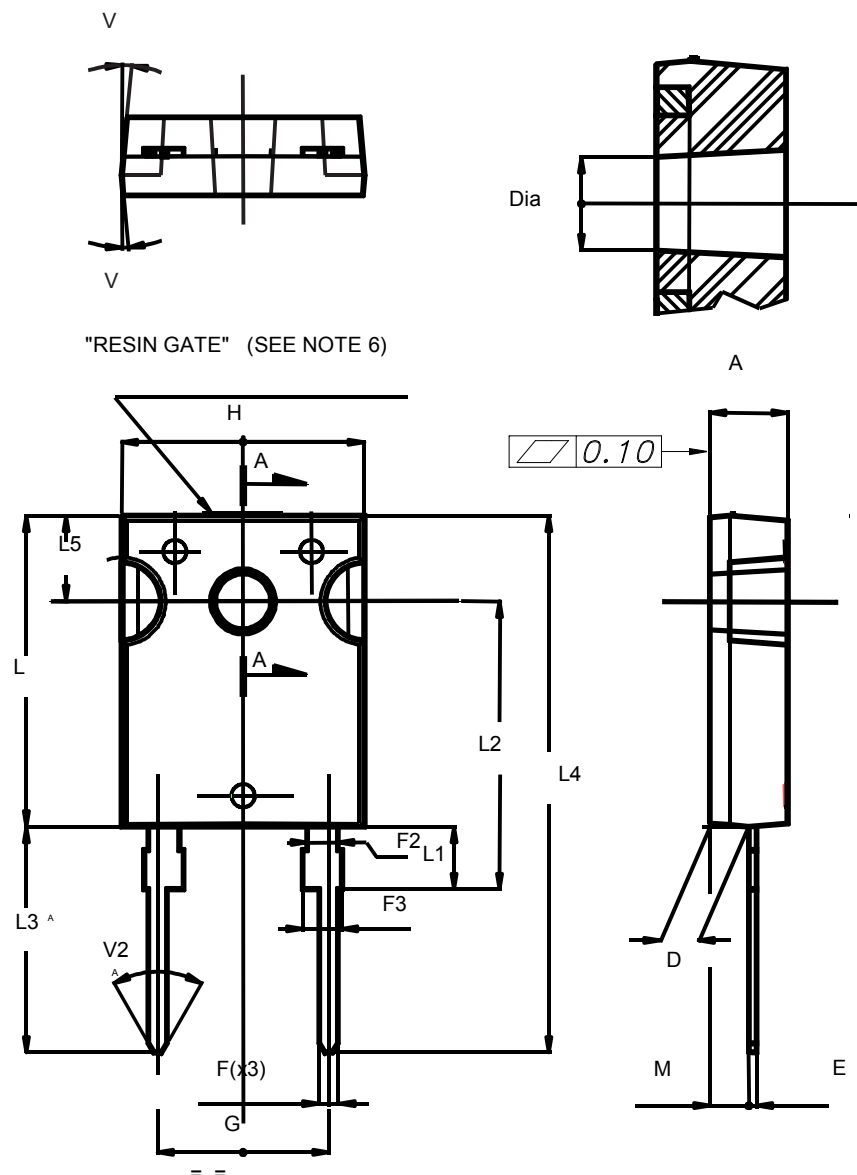

Note: This package drawing may slightly differ from the physical package. However, all the specified dimensions are guaranteed.

Figure 17. DO-247 package min-max drawing

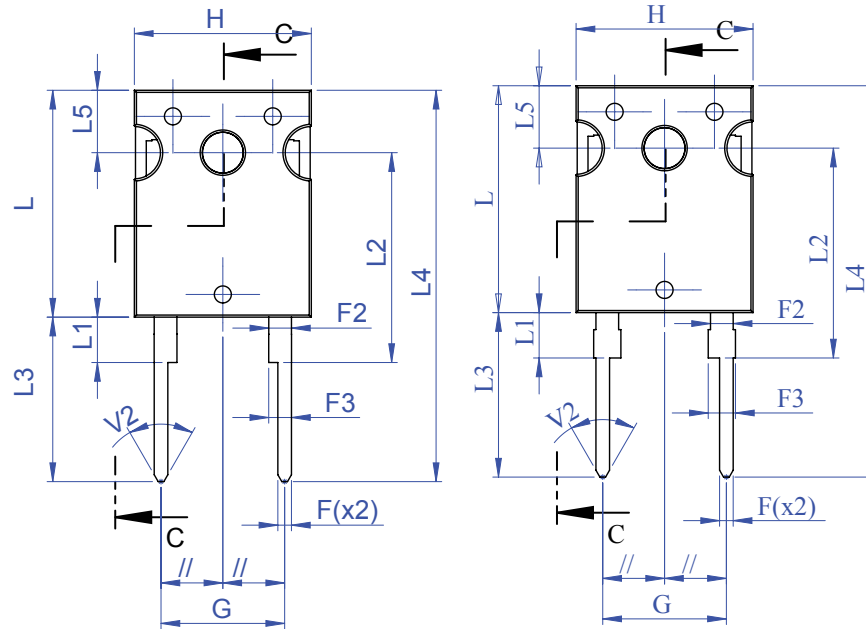

Table 6. DO-247 package mechanical data

Ref.	Dimensions					
	Millimeters			Inches (for reference only)		
	Min.	Typ.	Max.	Min.	Typ.	Max.
A	4.85		5.15	0.1909		0.2027
D	2.2		2.6	0.0866		0.1023
E	0.4		0.8	0.0157		0.0314
F	1		1.4	0.0393		0.0551
F2		2			0.0787	
F3	2		2.4	0.0787		0.0944
G		10.9			0.4291	
H	15.45		15.75	0.6082		0.6200
L	19.85		20.15	0.7814		0.7933
L1	3.7		4.3	0.1456		0.1692
L2		18.5			0.7283	
L3	14.2		14.8	0.5590		0.5826
L4		34.6			1.3622	
L5		5.5			0.2165	
M	2		3	0.0787		0.1181
V		5°			5°	
V2		60°			60°	
Diam.	3.55		3.65	0.1397		0.1437

3 Ordering information

Table 7. Ordering information

Order code	Marking	Package	Weight	Base qty.	Delivery mode
STTH30L06GY-TR	STTH30L06GY	D ² PAK	1.48 g	1000	Tape and reel
STTH30L06WY	STTH30L06WY	DO-247	4.36 g	30	Tube

Revision history

Table 8. Document revision history

Date	Version	Changes
24-Oct-2012	1	First issue.
21-Sep-2020	2	Updated package information. Added Figure 2. Conduction losses versus average forward current (sinusoidal waveform) .
21-Oct-2020	3	Added Figure 17 .

IMPORTANT NOTICE – PLEASE READ CAREFULLY

STMicroelectronics NV and its subsidiaries (“ST”) reserve the right to make changes, corrections, enhancements, modifications, and improvements to ST products and/or to this document at any time without notice. Purchasers should obtain the latest relevant information on ST products before placing orders. ST products are sold pursuant to ST’s terms and conditions of sale in place at the time of order acknowledgement.

Purchasers are solely responsible for the choice, selection, and use of ST products and ST assumes no liability for application assistance or the design of Purchasers’ products.

No license, express or implied, to any intellectual property right is granted by ST herein.

Resale of ST products with provisions different from the information set forth herein shall void any warranty granted by ST for such product.

ST and the ST logo are trademarks of ST. For additional information about ST trademarks, please refer to www.st.com/trademarks. All other product or service names are the property of their respective owners.

Information in this document supersedes and replaces information previously supplied in any prior versions of this document.

© 2020 STMicroelectronics – All rights reserved