

Automotive multiple supply for engine control

Datasheet - production data

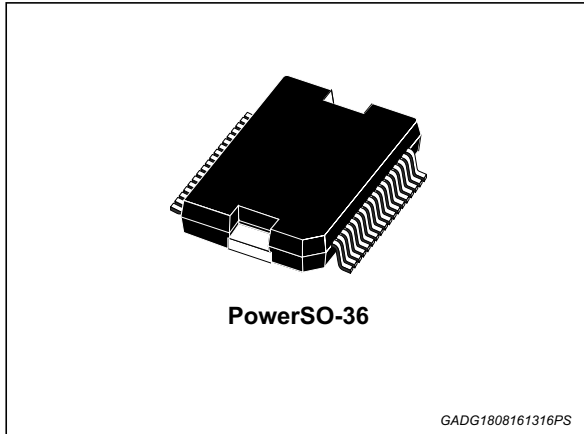

- Programmable 1 V or 1.5 V, 10% @ 10 mA, standby memory regulator (V_{KAM})
- Programmable 3.3 V or 2.6 V, 10% @ 10 mA alternate standby regulator (V_{STBY})
- Four $5\text{ V} \pm 7\text{ mV}$ @ 50 mA protected tracking regulators, one of them with selectable external voltage reference.
- Independent reset signals, RST5 and RSTL for the V_{DD5} , V_{DDL} supplies.
- Independent standby voltage monitor STANDBY_OK
- Two power supply enable signals for different voltage level signals
- Battery voltage thresholding - IGN
- Logic level thresholding - PSU_EN

Features



- AEC-Q100 qualified
- Buck converter pre-regulated supply rated for a minimum of 2 A (RMS)
- Optional Boost converter for low battery conditions
- 5 V, 2% @ 1 A, V_{DD5} low dropout (LDO) regulator
- Programmable 3.3 V or 2.6 V, 2% @ 1 A, V_{DDL} LDO regulator with external pass transistor
- Programmable microcontroller core voltage LDO regulator, V_{CORE} 2% @ 1 A with external voltage divider and pass transistor

Description

The L9758 is a multiple output voltage regulator utilizing linear, switchmode (buck and boost) and tracking regulators to support high end automotive microcontrollers used in powertrain applications.

The L9758 provides two standby power regulators as well as controllable LDO regulators.

The L9758 has power on reset functionality and controlled slew rate of the V_{DD5} , V_{DDL} and V_{CORE} .

Table 1. Device summary

Order code	Temperature range	Package	Packing
L9758	-40 °C to +125 °C	PowerSO-36	Tube
E-L9758BBTR			Tape & Reel

Contents

1	Pins configuration	6
2	Functional block diagram	9
3	Operating conditions	10
3.1	Absolute maximum ratings	10
3.2	Operating ranges	11
3.3	Thermal data	11
4	Electrical characteristics	12
4.1	General DC characteristics	12
4.2	BUCK pre-regulator	13
4.3	Boost pre-regulator	14
4.4	VDD5 linear regulator	15
4.5	VDDL linear regulator	15
4.6	VCORE linear regulator	16
4.7	VKAM linear regulator	17
4.8	VSTBY linear regulator	17
4.9	VSA, VSB, VSC, VSD tracking linear regulator	18
4.10	RST5 and RSTL reset signals	18
4.11	IGN and PSU_EN inputs	19
4.12	STBY_OK signal	20
5	Functional description	21
5.1	General function	21
5.2	Switching pre-regulator	21
5.3	VDD5, VDDL and VCORE linear regulators	21
5.4	Tracking regulators	22
5.5	VKAM and VSTBY linear regulators	22
5.6	RESET monitors	23
5.7	Thermal protection	23
5.8	Reference current	23

6	Operating modes	24
6.1	Standby mode	24
6.2	Run mode	24
6.2.1	Entry into RUN mode	24
6.3	Power down	25
6.4	Low voltage operation	26
6.5	High voltage operation	26
7	Package information	27
7.1	PowerSO-36 package information	27
8	Revision history	29

List of tables

Table 1.	Device summary	1
Table 2.	Pins description.	6
Table 3.	Control pins description	7
Table 4.	Absolute maximum ratings	10
Table 5.	Operating ranges	11
Table 6.	Thermal data.	11
Table 7.	General DC characteristics.	12
Table 8.	BUCK pre-regulator	13
Table 9.	Boost pre-regulator	14
Table 10.	VDD5 linear regulator	15
Table 11.	VDDL linear regulator	15
Table 12.	VCORE linear regulator	16
Table 13.	VKAM linear regulator.	17
Table 14.	VSTBY linear regulator.	17
Table 15.	VSA, VSB, VSC, VSD tracking linear regulator	18
Table 16.	RST5 reset signals	18
Table 17.	RSTL reset signals	19
Table 18.	IGN and PSU_EN inputs.	19
Table 19.	STBY_OK signal.	20
Table 20.	PowerSO-36 package mechanical data	28
Table 21.	Document revision history.	29

List of figures

Figure 1.	Pins connection (top view)	6
Figure 2.	Functional block diagram	9
Figure 3.	Current reference generator	23
Figure 4.	Power up/down sequence.	25
Figure 5.	PowerSO-36 package outline	27

1 Pins configuration

Figure 1. Pins connection (top view)

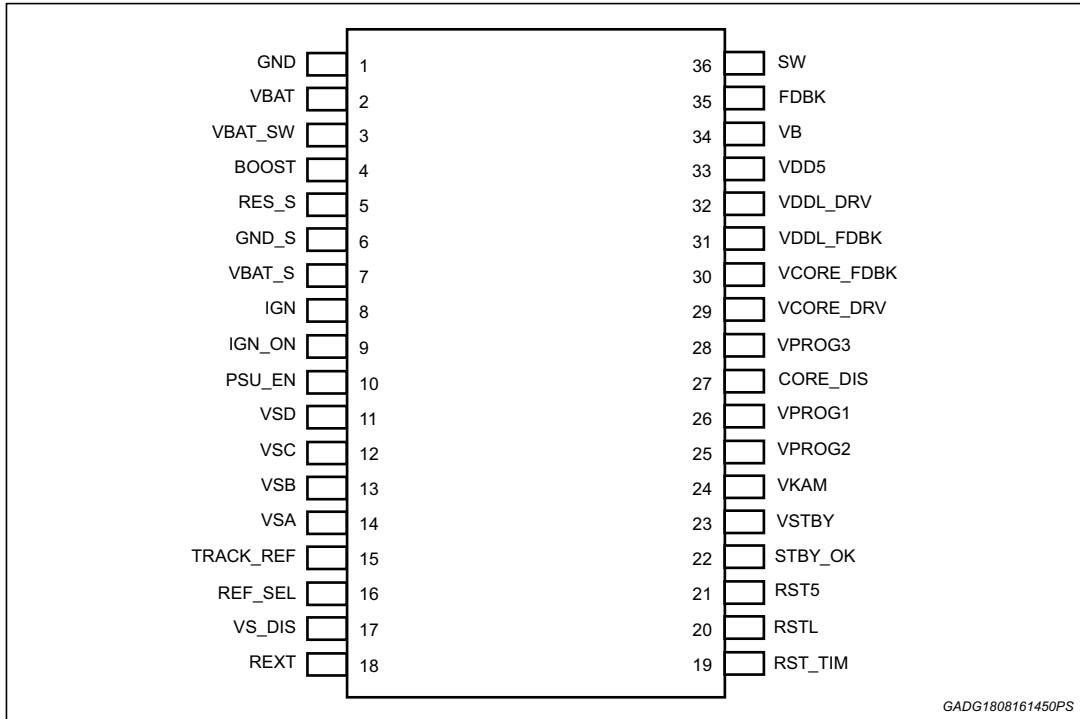

Table 2. Pins description

Pin #	Name	Description
1	GND	Power ground
2	VBAT	Battery power source
3	VBAT_SW	Switched battery power source
4	BOOST	External boost transistor predriver output
5	RES_S	Boost (+) current comparator input
6	GND_S	Boost (-) current comparator input
7	VBAT_S	Battery feedback for boost controller
8	IGN	Ignition switch
9	IGN_ON	Ignition state
10	PSU_EN	Power supply enable
11	VSD	Tracking regulator D
12	VSC	Tracking regulator C
13	VSB	Tracking regulator B
14	VSA	Tracking regulator A
15	TRACK_REF	Tracking A voltage reference

Table 2. Pins description (continued)

Pin #	Name	Description
16	REF_SEL	Tracking A voltage reference selection
17	VS_DIS	Sensor supply disable
18	REXT	External current reference resistance
19	RST_TIM	Reset timer adjustment
20	RSTL	VDDL regulator reset output
21	RST5	VDD5 regulator reset output
22	STBY_OK	Standby regulator monitor
23	VSTBY	Standby regulator output
24	VKAM	Standby memory regulator output
25	VPROG2	Standby regulator voltage selection (VSTBY)
26	VPROG1	Standby memory regulator voltage selection (VKAM)
27	CORE_DIS	VDDL and VCORE disable
28	VPROG3	VDDL voltage selection
29	VCORE_DRV	VCORE external pass transistor predriver output
30	VCORE_FDBK	VCORE feedback
31	VDDL_FDBK	VDDL feedback
32	VDDL_DRV	VDDL external pass transistor predriver output
33	VDD5	VDD5 linear regulator output
34	VB	Switching preregulator output
35	FDBK	Switching voltage feedback
36	SW	Buck regulator switch output

Table 3. Control pins description

Pin name	Logic level	Description	Type of I/O
IGN	Low	Enter in Stand-by Mode if also PSU_EN is low	Pull down
	High	Enter in Run Mode	
IGN_ON	Low	IGN is high	Open drain
	High	IGN is low	
PSU_EN	Low	Enter in Stand-by Mode if also IGN is low	Pull down
	High	Enter in Run Mode	
VS_DIS	Low	Enable VSB, VSC, VSD tracking regulators	Pull down
	High	Disable VSB, VSC, VSD tracking regulators	

Table 3. Control pins description (continued)

Pin name	Logic level	Description	Type of I/O
Ref_Sel	Low	Voltage reference for VSA tracking regulator is VDD5	Pull down
	High	Voltage reference for VSA tracking regulator is VTRACK_REF	
RSTL	Low	VDDL output regulator out of range (under voltage)	Open collector
	High	VDDL output regulator fully operational	
RST5	Low	VDD5 output regulator out of range (under voltage)	Open collector
	High	VDD5 output regulator fully operational	
VPROG1	Low	VKAM regulator output programmed to 1V	Pull up
	High	VKAM regulator output programmed to 1.5V	
VPROG2	Low	VSTBY regulator output programmed to 2.6V	Pull up
	High	VSTBY regulator output programmed to 3.3V	
VPROG3	Low	VDLL regulator output programmed to 2.6V	Pull up
	High	VDLL regulator output programmed to 3.3V	
CORE_DIS	Low	Enable VDLL and VCORE linear regulators	Pull down
	High	Disable VDLL and VCORE linear regulators	
STBY_OK	Low	VSTBY output regulator out of range (under voltage)	Open drain
	High	VSTBY output regulator fully operational	

2 Functional block diagram

Figure 2. Functional block diagram

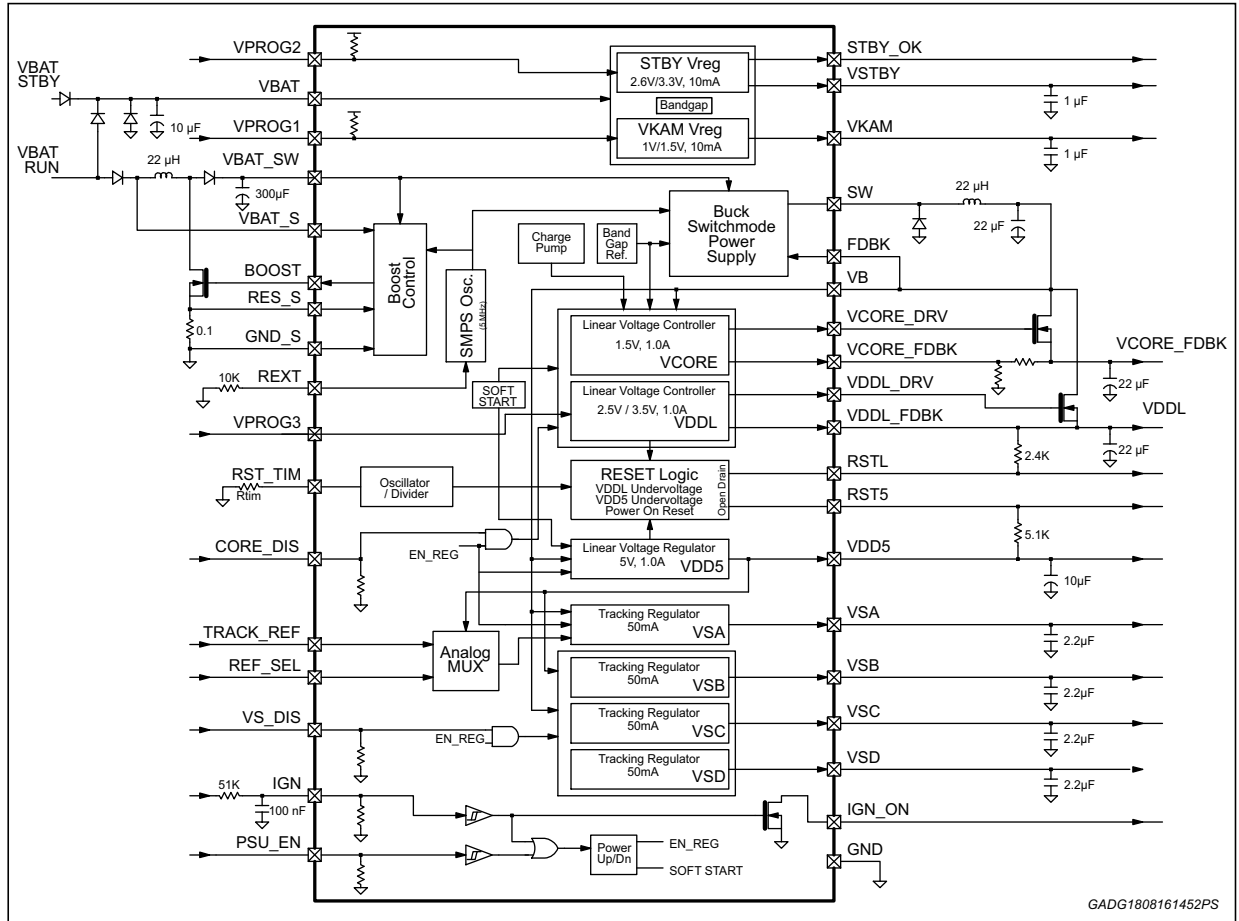

3 Operating conditions

3.1 Absolute maximum ratings

This part may be irreparably damaged if taken outside the specified absolute maximum ratings. Operation above the absolute maximum ratings may also cause a decrease in reliability.

Table 4. Absolute maximum ratings

Symbol	Parameter	Value	Unit
V _{BAT} , V _{BAT_SW} , V _{BAT_S}	Battery supply voltage	-0.3 to 40	V
V _{IGN}	Ignition input voltage (with at least 10K external resistance)	-2.0 to 40	V
V _{I-digital}	Digital input voltages (PSU_EN, VS_EN, VPROG1, VPROG2, VPROG3, VDDL/VCORE_EN, REF_SEL)	-0.3 to 7	V
V _{I-analog}	Analog input voltages (REXT, TRACK_REF, RST_TIM, VDDL_FDBK, VCORE_FDBK)	-0.3 to 7	V
V _B	Linear regulator supply (VB)	-0.3 to 40	V
V _{FDBK}	Switching feedback (FDBK)	-0.3 to 40	V
V _{SW}	Buck regulator switch output (SW)	-2 to 40	V
V _{O-digital}	Digital output voltages (IGN_ON, RSTL, RST5, BOOST, STBY_OK)	-0.3 to 7	V
V _{OR}	Regulator output voltages (VDD5, VSTBY, VKAM)	-0.3 to 7	V
V _{VSx}	Regulator output voltages (VSA, VSB, VSC, VSD)	-3 to 40	V
V _{CORE_DRV} , V _{DDL_DRV}	External regulator predriver output (VCORE_DRV, VDDL_DRV)	-0.3 to 15	V
I _{SMPS}	Switching preregulator current	0 to 4.2	A
T _{op}	Operating temperature	-40 to 125	°C
T _{stg}	Storage temperature	-50 to 150	°C
T _j	Max junction temperature	150	°C
V _{ESD}	Max ESD (human body model)	±2	KV

Warning: Exceeding these values might destroy this part. This part is not guaranteed to function properly at these ratings. The CMOS inputs and outputs should never go above 5 V + 0.3 V or below GND - 0.3 V without protection (series resistance). If this occurs, the device might be destroyed by latch-up and/or the output levels might not be controlled by the inputs. Unused inputs must be connected to GND and unused outputs should be left open and programmed to a low state. Unused I/O pins should be programmed as outputs, left open, and programmed to a low state.

3.2 Operating ranges

Full specification parameters cannot be guaranteed outside the operating ranges. Once the condition has returned within the specified operating ranges, the part will recover with no damage or degradation.

Table 5. Operating ranges

Symbol	Parameter	Value	Unit
V_{BAT} , V_{BAT_SW} , V_{BAT_S}	Battery supply voltage	4 to 26.5 4 to 40 (t < 400 ms)	V
V_{IGN}	Ignition input voltage (with at least 10K external resistance)	4 to 26.5	V
$V_{I-digital}$	Digital input voltages (PSU_EN, VS_EN, VPROG1, VPROG2, VPROG3, VDDL/VCORE_EN, REF_SEL)	-0.3 to 5.3	V
$V_{I-analog}$	Analog input voltages (REXT, TRACK_REF, RST_TIM VDDL_FDBK, VCORE_FDBK)	-0.3 to 5.3	V
I_{AVE}	Switching preregulator average current	0 to 2.5	A
T_{op}	Operating temperature	-40 to 125	°C
T_j	Junction temperature	-40 to 150	°C

3.3 Thermal data

Table 6. Thermal data

Symbol	Parameter	Value	Unit
$R_{th(j-case)}$	Thermal resistance junction-to-case	2	°C/W

4 Electrical characteristics

All voltage values are, if not otherwise stated, relative to ground. Current flow into a pin is positive. If not otherwise stated, all rise times are between 10% and 90%, fall times between 90% and 10% and delay times at 50% of the relevant steps.

4.1 General DC characteristics

$T_{amb} = -40\text{ °C to }125\text{ °C}$, $V_{BAT} = V_{BAT_SW} = 5.5\text{ to }26.5\text{ V}$, unless otherwise specified.

Table 7. General DC characteristics

Symbol	Parameter	Test condition	Min.	Typ.	Max.	Unit
$I_{BAT_SW_SB}$	Quiescent current at pin BAT_SW	$V_{BAT} = 0\text{ V};$ $V_{BAT_SW} = 12\text{ V}$	-	-	150	μA
I_{Q_OFF}	Supply current in OFF state	$I_{VBAT_SW} + I_{VBAT}$	-	-	120	μA
V_{LVI_LOW}	Low voltage inhibit Low threshold	-	3.5	-	3.9	V
V_{LVI_HIGH}	Low voltage inhibit High threshold	-	4.0	-	4.5	V
V_{LVI_HYS}	Low voltage inhibit hysteresis	-	0.3	-	1	V
V_{ST}	Linear Start-up voltage	-	3.8	-	4.8	V
V_{REXT}	Rext Voltage	-	1.18	-	1.24	V
V_{TH_VSEN}	VS_EN input threshold	-	0.8	-	2	V
$V_{VDDL/VCORE_EN}$	VDDL/VCORE_EN input threshold	-	0.8	-	2	V
V_{PROG1_LOW}	PROG1 input Low Voltage	-	-	-	0.8	V
V_{PROG2_LOW}	PROG2 input Low Voltage	-	-	-	0.8	V
V_{PROG3_LOW}	PROG3 input Low Voltage	-	-	-	0.8	V
V_{DDL_ENUP}	Vddl Power-up enable	-	1	-	2	V

4.2 BUCK pre-regulator

$T_{amb} = -40\text{ }^{\circ}\text{C}$ to $125\text{ }^{\circ}\text{C}$, $V_{BAT} = V_{BAT_SW} = 5.5$ to 26.5 V ; unless otherwise specified.

Table 8. BUCK pre-regulator

Symbol	Parameter	Test condition	Min.	Typ.	Max.	Unit
F_{SW}	Operating frequency	$R_{ext} = 10.0\text{ k}\Omega \pm 1\%$ $V_{BAT_SW} = 13.5\text{ V}$	300	-	450	kHz
R_{dsON}	High side switch ON resistance	$V_{BAT_SW} = 6.0\text{ V}$	-	-	0.25	Ω
I_{ST_MAX}	Average current during start-up	$V_B = 3.0\text{ V}$	0.3	-	0.7	A
V_{BREG}	Output voltage	$7.0\text{ V} < V_{BAT_SW} < 18\text{ V}$ $0.25\text{ A} < I_{VBAT} < 2.0\text{ A}$	5.5	-	6.1	V
Vb100	100% Duty Cycle operation threshold	Voltage sensed at VBAT_SW pin	6.2	-	7.8	V
Vb100h	100% Duty Cycle operation threshold hysteresis		0.05	-	0.8	V
ΔV_{pre}	Load regulation	$\Delta I_{VB} = 0.1\text{ A} - 2\text{ A}$ $V_{BAT_SW} = 13.5\text{ V}$	-	-	400	mV
V_{rpre}	Voltage ripple, p-p	$L = 22\text{ }\mu\text{H}$, $C = 22\text{ }\mu\text{F X7R}$ $V_{BAT_SW} = 13.5\text{ V}$	-	-	300	mV
T_s	Start time	$L = 22\text{ }\mu\text{H}$, $C = 22\text{ }\mu\text{F X7R}$	-	-	1.4	ms
DCmin	Minimum duty cycle	-	10	-	18	%
EFF	Efficiency	$V_{BAT_SW} = 13.5\text{ V}$ $I_{VB} = 0.5\text{ A}$ $V_{BAT_SW} = 13.5\text{ V}$ $I_{VB} = 2\text{ A}$	70 70	-	-	%
L Rs	Output Inductance	-	15	22	30 75	μH m Ω
C ESR	Output capacitance	-	10 0	-	100 160	μF m Ω
Ov	Power-up overvoltage	$V_{BAT_SW} < 26.5\text{ V}$ $0.25\text{ A} < I_{VBAT} < 2.0\text{ A}$	15	-	200	mV
Tr_sw Tf_sw	SW rising and falling time	$7.0\text{ V} < V_{BAT_SW} < 18\text{ V}$ $I_{VBAT} < 2.0\text{ A}$ (20%, 80%)	10	-	150	μs

4.3 Boost pre-regulator

$T_{amb} = -40\text{ }^{\circ}\text{C}$ to $125\text{ }^{\circ}\text{C}$, $V_{BAT} = V_{BAT_SW} = 5.5$ to 26.5 V , unless otherwise specified.

Table 9. Boost pre-regulator

Symbol	Parameter	Test condition	Min.	Typ.	Max.	Unit
FSW	Operating frequency	$R_{ext} = 10.0\text{ k}\Omega \pm 1\%$ $V_{BAT_SW} = 13.5\text{ V}$	300	-	450	kHz
V_{B_REG}	Output voltage	$4.0\text{ V} < V_{BAT_S} < 7\text{ V}$, $0.25\text{ A} < I_{VB} < 2.0\text{ A}$	8.5	-	10	V
BoostONth	Boost enable threshold	Voltage sensed at VBAT_S pin	7.0	-	8.3	V
BoostOFFth	Boost disable threshold		7.0	-	8.3	V
V_{BOOST_HY}	Boost operation threshold hysteresis	Voltage sensed at VBAT_S pin	0.05	-	0.9	V
ΔV_{BOOST}	Load regulation	$\Delta I_{VB} = 0.1\text{ A}$ – 2 A $V_{BAT_S} = 4\text{ V}$	-	-	600	mV
V_{R_VBOOST}	Voltage ripple, p-p	$L = 22\text{ }\mu\text{H}$, $C = 300\text{ }\mu\text{F}$ X7RX7R $V_{BAT_S} = 4\text{ V}$	-	-	600	mV
V_{OLB}	Boost predriver low level voltage	$I_{sink} = 1\text{ mA}$	-	-	0.2	V
V_{OHB}	Boost predriver low level voltage	$I_{source} = 200\text{ }\mu\text{A}$	4.8	-	-	V
T_{RB}	Boost predriver rise time	$CI = 1\text{ nF}$	50	-	180	ns
T_{FB}	Boost predriver fall time	$CI = 1\text{ nF}$	20	-	100	ns
L Rs	Output inductance	-	15	22	30 75	μH $\text{m}\Omega$
C ESR	Output capacitance	-	100 10	300	900 200	μF $\text{m}\Omega$
R_{SENSE}	Sensing resistor	-	40	50	-	$\text{m}\Omega$

4.4 VDD5 linear regulator

$T_{amb} = -40\text{ °C}$ to 125 °C , $V_{BAT} = V_{BAT_SW} = 5.5$ to 26.5 V , unless otherwise specified.

Table 10. VDD5 linear regulator

Symbol	Parameter	Test condition	Min.	Typ.	Max.	Unit
V_{DD5}	Output voltage	$5\text{ mA} < I_{DD5} < 1\text{ A}$ $V_{BAT_SW} \Rightarrow 5.7\text{ V}$ $5\text{ mA} < I_{DD5} < 800\text{ mA}$ $V_{BAT_SW} = 5.5\text{ V}$	4.9	-	5.1	V
		$5\text{ mA} < I_{DD5} < 1\text{ A}$ $V_{BAT_SW} \geq 4\text{ V}$	3.3	-	4.0	
I_{DD5_LIM}	Current limit	$V_{DD5} = 4.75\text{ V}$	1200	-	2500	mA
C_{DD5} ESR	Output capacitor	Ceramic or Tantalum	4.7	-	100	μF
		$C = 4.7\text{ }\mu\text{F}$	0	-	160	m Ω
R_{RDD5}	Ripple rejection	$F = 375\text{ kHz}$	26	-	-	dB
V_{DD5_MAX}	Maximum overshoot	$\Delta V_B/\Delta t < 70\text{ V/ms}$ $V_{BAT_SW} = 4\text{ V} \rightarrow 8\text{ V}$	-	-	5.5	V
$\Delta V_{DD5}/\Delta t$	Output voltage slew rate at power-up	$5\text{ mA} < I_{DD5} < 1\text{ A}$ $V_{BAT_SW} = 13.5\text{ V}$	10	-	20	V/ms
I_{DD5}	Load current	-	5	-	1000	mA
V_{DD5_lineR}	Line regulation	$6.0\text{ V} < V_B < 7\text{ V}$	-25	-	+25	mV
V_{DD5_loadR}	Load regulation	$5\text{ mA} < I_{DD5} < 1\text{ A}$	-25	-	+25	mV
$V_{DD5}-V_{ddl}$	Start up	$V_{DD5}-V_{ddl}$ during start up	0.5	-	3.1	mV

4.5 VDDL linear regulator

$T_{amb} = -40\text{ °C}$ to 125 °C , $V_{BAT} = V_{BAT_SW} = 5.5$ to 26.5 V , unless otherwise specified.

Table 11. VDDL linear regulator

Symbol	Parameter	Test condition	Min.	Typ.	Max.	Unit
V_{DDL}	Output voltage	$5\text{ mA} < I_{DDL} < 1\text{ A}$, $V_{PROG3} = \text{Open}$ $4.0\text{ V} < V_{BAT_SW} < 18\text{ V}$	3.23	-	3.37	V
		$5\text{ mA} < I_{DDL} < 1\text{ A}$, $V_{PROG3} = \text{Low}$ $4.0\text{ V} < V_{BAT_SW} < 18\text{ V}$	2.55	-	2.65	
C_{DDL} ESR	Output capacitor	Ceramic or Tantalum	4.7	-	100	μF
			0	-	160	m Ω
RR_{DDL}	Ripple rejection	$F = 375\text{ kHz}$	26	-	-	dB

Table 11. VDDL linear regulator (continued)

Symbol	Parameter	Test condition	Min.	Typ.	Max.	Unit
V_{DDL_MAX}	Maximum overshoot	5 mA < I_{DDL} < 1 A, V_{PROG3} = Open 4.0 V < V_{BAT_SW} < 18 V $\Delta V_B/\Delta t$ < 70 V/ms 5 mA < I_{DDL} < 1 A, V_{PROG3} = Low 4.0 V < V_{BAT_SW} < 18 V $\Delta V_B/\Delta t$ < 70 V/ms	-	-	3.75 3.6	V
$\Delta V_{DDL}/\Delta t$	Output voltage slew rate at power-up	5 mA < I_{DDL} < 1 A V_{BAT_SW} = 13.5 V	5	-	25	V/ms
I_{DDL}	Load current	-	5	-	1000	mA
V_{DDL_lineR}	Line regulation	5.5 V < V_{BAT_SW} < 7 V	-8	-	+8	mV
V_{DDL_loadR}	Load regulation	5 mA < I_{DDL} < 1 A	-8	-	+8	mV

4.6 VCORE linear regulator

T_{amb} = -40 °C to 125 °C, V_{BAT} = V_{BAT_SW} = 5.5 to 26.5 V, unless otherwise specified.

Table 12. VCORE linear regulator

Symbol	Parameter	Test condition	Min.	Typ.	Max.	Unit
V_{CORE}	Output voltage	5 mA < I_{CORE} < 1 A; 4.0 V < V_{BAT_SW} < 18 V	1.47	-	1.53	V
C_{ddL} ESR	Output capacitor	Ceramic or Tantalum	4.70 0	-	100 160	μ F m Ω
RR _{ddL}	Ripple rejection	F = 375 kHz	26	-	-	dB
V_{CORE_M}	Maximum overshoot	5 mA < I_{CORE} < 1 A 4.0 V < V_{BAT_SW} < 18 V	-	-	1.7	V
$\Delta V_{CORE}/\Delta t$	Output voltage slew rate at power-up	5 mA < I_{CORE} < 1 A V_{BAT_SW} = 13.5 V	5	-	25	V/ms
I_{CORE}	Load current	-	5	-	1000	mA
V_{CORE_PROG}	Range of programmability	Using external resistor divider	1.05	1.5	2.8	V
V_{CORE_FBK}	Feedback voltage	-	0.98	-	1.02	V
V_{CORE_lineR}	Line regulation	5.5 V < V_{BAT_SW} < 7 V	-25	-	+25	mV
V_{CORE_loadR}	Load regulation	5 mA < I_{CORE} < 1 A	-25	-	+25	mV

4.7 VKAM linear regulator

$T_{amb} = -40\text{ }^{\circ}\text{C}$ to $125\text{ }^{\circ}\text{C}$, $V_{BAT} = V_{BAT_SW} = 5.5$ to 26.5 V , unless otherwise specified.

Table 13. VKAM linear regulator

Symbol	Parameter	Test condition	Min.	Typ.	Max.	Unit
V_{KAM}	Output voltage	$0.1\text{ mA} < I_{VKAM} < 10\text{ mA}$, $V_{PROG1} = \text{Low}$ $4.0\text{ V} < V_{BAT} < 18\text{ V}$	0.9	-	1.1	V
		$0.1\text{ mA} < I_{VKAM} < 10\text{ mA}$, $V_{PROG1} = \text{Open}$ $4.0\text{ V} < V_{BAT} < 18\text{ V}$	1.37	-	1.65	
C_{VKAM} ESR	Output capacitor	Ceramic	0.1 0	-	4.7 20	μF m Ω
RR_{VKAM}	Ripple rejection	$F=375\text{ kHz}$	26	-	-	dB
V_{KAM_M}	Maximum overshoot (absolute value relative to GND)	$0.1\text{ mA} < I_{VKAM} < 10\text{ mA}$, $V_{PROG1} = \text{Low}$ $4\text{ V} < V_{BAT} < 18\text{ V}$	-	-	1.2	V
		$0.1\text{ mA} < I_{VKAM} < 10\text{ mA}$, $V_{PROG1} = \text{Open}$ $4\text{ V} < V_{BAT} < 18\text{ V}$	-	-	1.7	
Iddkamsh	Current limit	$V_{KAM} = 0.5\text{ V}$	11	-	50	mA
I_{KAM}	Load current	-	0.1	-	10	mA
$V_{KAM\text{lineR}}$	Line regulation	$6\text{ V} < V_{BAT} < 18\text{ V}$	-25	-	+25	mV
$V_{KAM\text{loadR}}$	Load regulation	$0.1\text{ mA} < I_{KAM} < 10\text{ mA}$	-25	-	+25	mV

4.8 VSTBY linear regulator

$T_{amb} = -40\text{ }^{\circ}\text{C}$ to $125\text{ }^{\circ}\text{C}$, $V_{BAT} = V_{BAT_SW} = 5.5$ to 26.5 V , unless otherwise specified.

Table 14. VSTBY linear regulator

Symbol	Parameter	Test condition	Min.	Typ.	Max.	Unit
V_{STBY}	Output voltage	$0.1\text{ mA} < I_{STBY} < 10\text{ mA}$, $V_{PROG2} = \text{Low}$ $4\text{ V} < V_{BAT} < 18\text{ V}$	2.47	-	2.73	V
		$0.1\text{ mA} < I_{STBY} < 10\text{ mA}$, $V_{PROG2} = \text{Open}$ $4\text{ V} < V_{BAT} < 18\text{ V}$	3.13	-	3.47	
C_{STBY} ESR	Output capacitor	Ceramic	0.1 0	-	10 20	μF m Ω
RR_{STBY}	Ripple rejection	$F = 350\text{ kHz}$	26	-	-	dB
V_{STBY_M}	Maximum overshoot (absolute value relative to GND)	$0.1\text{ mA} < I_{STBY} < 10\text{ mA}$, $V_{PROG2} = \text{Low}$ $4\text{ V} < V_{BAT} < 18\text{ V}$	-	-	3.05	V
		$0.1\text{ mA} < I_{STBY} < 10\text{ mA}$, $V_{PROG2} = \text{Open}$ $4\text{ V} < V_{BAT} < 18\text{ V}$	-	-	3.75	
I_{STBYsh}	Current limit	$V_{STBY} = 0.5\text{ V}$	11	-	50	mA
I_{STBY}	Load current	-	0.1	-	10	mA
$V_{STBY\text{lineR}}$	Line regulation	$6\text{ V} < V_{BAT} < 18\text{ V}$	-25	-	+25	mV
$V_{STBY\text{loadR}}$	Load regulation	$0.1\text{ mA} < I_{STBY} < 10\text{ mA}$	-25	-	+25	mV

4.9 VSA, VSB, VSC, VSD tracking linear regulator

$T_{amb} = -40\text{ °C}$ to 125 °C , $V_{BAT} = V_{BAT_SW} = 5.5$ to 26.5 V , unless otherwise specified.

Table 15. VSA, VSB, VSC, VSD tracking linear regulator

Symbol	Parameter	Test condition	Min.	Typ.	Max.	Unit
ΔV_{TRK}	Output voltage tracking accuracy	$1\text{ mA} < I_{t1} < 50\text{ mA}$, $6\text{ V} < V_{BAT_SW} < 18\text{ V}$ $1\text{ mA} < I_{t1} < 50\text{ mA}$, $4\text{ V} < V_{BAT_SW} < 6\text{ V}$	-7 -50	-	10 50	mV
I_{TRKsh}	Current limit	$V_{tck} = 4.75\text{ V}$	51	-	100	mA
C_{TRK} ESR	Output load capacitor	Ceramic or Tantalum	1 0	-	16 3	μF m Ω
C_{tckmin} ESRmin	Minimum output capacitor for stability	Ceramic or Tantalum	1 0	-	3	μF Ω
RR_{TRK}	Ripple rejection	$F = 375\text{ kHz}$	26	-	-	dB
V_{drop}	Dropout voltage	$I_{load} = 50\text{ mA}$	-	-	300	mV
T_{TSD}	Thermal shutdown	$V_{tck} = 4.75\text{ V}$ (current limitation)	165	-	185	$^{\circ}\text{C}$
T_{HYST}	Thermal hysteresis	$V_{tck} = 4.75\text{ V}$ (current limitation)	5	-	15	$^{\circ}\text{C}$
I_{TRK}	Load current	-	1	-	50	mA

4.10 RST5 and RSTL reset signals

$T_{amb} = -40\text{ °C}$ to 125 °C , $V_{BAT} = V_{BAT_SW} = 5.5$ to 26.5 V , unless otherwise specified.

Table 16. RST5 reset signals

Symbol	Parameter	Test condition	Min.	Typ.	Max.	Unit
I_{RST5_H}	Reset "high" leakage current	$V_{RST5} = 5.15\text{ V}$	-3.0	-	-	μA
V_{RST5_L}	Reset "low" output voltage	$V_{DD5} = 4.5\text{ V}$ $I_{re} = 5\text{ mA}$ $V_{DD5} = 1.0\text{ V}$ $I_{re} = 1\text{ mA}$	-	-	0.4 0.4	V
V_{FTH_RST5}	Reset threshold decreasing	$\Delta V_{DD5}/\Delta t < 0$	4.5	-	$V_{DD5} - 0.2$	V
V_{RTH_RST5}	Reset threshold increasing	$\Delta V_{DD5}/\Delta t > 0$	4.5	-	$V_{DD5} - 0.07$	V
V_{HY_RST5}	Reset threshold hysteresis	-	50	-	-	mV
t_{ACT_RST5}	Reset activation out of tolerance duration	-	15	-	25	μs
t_{DEL_RST5}	Reset delay	$4.7\text{ k}\Omega < R_{ext} < 47\text{ k}\Omega$	1	-	10	ms
t_{ERR_RST5}	Reset delay accuracy	$R_{ext} \pm 1\%$	-15	-	+15	%

Table 17. RSTL reset signals

Symbol	Parameter	Test condition	Min.	Typ.	Max.	Unit
I_{RSTL_H}	Reset "high" leakage current	$V_{DDL} = 5.15\text{ V}$	-3.0	-	-	μA
V_{RSTL_L}	Reset "low" output voltage	$V_{DDL}=5.0\text{V } I_{re}=5\text{mA}$ $V_{DDL}=1.0\text{V } I_{re}=1\text{mA}$	-	-	0.4 0.4	V
V_{FTH_RSTL}	Reset threshold decreasing	$\Delta V_{DDL}/\Delta t < 0$, $V_{PROG3}=\text{Low}$	2.375	-	$V_{DDL}-0.05$	V
V_{RTH_RSTL}	Reset threshold increasing	$\Delta V_{DDL}/\Delta t < 0$, $V_{PROG3}=\text{Low}$	2.375	-	$V_{DDL}-0.02$	V
$V_{FTH_RSTL_O}$	Reset threshold decreasing	$\Delta V_{DDL}/\Delta t < 0$, $V_{PROG3}=\text{Open}$	3.13	-	$V_{DDL}-0.05$	V
$V_{RTH_RSTL_O}$	Reset threshold increasing	$\Delta V_{DDL}/\Delta t < 0$, $V_{PROG3}=\text{Open}$	3.13	-	$V_{DDL}-0.02$	V
V_{HY_RSTL}	Reset threshold hysteresis	-	40	-	-	mV
t_{ACT_RSTL}	Reset activation out of tolerance duration	-	15	-	25	μs
t_{DEL_RSTL}	Reset delay	$1\text{nF} < C_{EXT} < 10\text{nF}$; $4.7\text{k}\Omega < R_{ext} < 47\text{k}\Omega$	1	-	10	ms
t_{ERR_RSTL}	Reset delay accuracy	$R_{ext} \pm 1\%$	-15	-	+15	%

4.11 IGN and PSU_EN inputs

$T_{amb} = -40\text{ }^{\circ}\text{C}$ to $125\text{ }^{\circ}\text{C}$, $V_{BAT} = V_{BAT_SW} = 5.5$ to 26.5 V , unless otherwise specified.

Table 18. IGN and PSU_EN inputs

Symbol	Parameter	Test condition	Min.	Typ.	Max.	Unit
V_{TH_IGN}	IGN input threshold	threshold @ IGN pin	2	-	3.6	V
V_{HYS_IGN}	IGN input threshold hysteresis	-	0.2	-	1.4	V
R_{PD_IGN}	IGN pull-down resistor	-	300	-	1100	k Ω
V_{TH_PSUEN}	PSU_EN input threshold	-	0.9	-	$0.55^* V_{STBY}$	V
V_{HYS_PSUEN}	PSU_EN input threshold hysteresis	-	0.2	-	0.8	V
R_{PD_PSUEN}	PSU pull-down resistor	-	50	-	230	k Ω
V_{OL_IGNON}	IGN_ON "low" output voltage	$I_{ol}=1\text{mA}$			0.4	V
R_{IGN_EXT}	IGN external input resistance		10		50	k Ω

4.12 STBY_OK signal

$T_{amb} = -40^{\circ}\text{C}$ to 125°C , $V_{BAT} = V_{BAT_SW} = 5.5$ to 26.5V , unless otherwise specified.

Table 19. STBY_OK signal

Symbol	Parameter	Conditions	Min	Typ	Max	Units
T_{h_stbyok}	VstandbyOK threshold	$\Delta V_{STBY}/\Delta t < 0$	-8,5	-	-3,5	%
$T_{stbydly}$	STBY_OK filter time	-	15	-	25	μs
T_{stbyok}	STBY_OK delay accuracy	-	10	-	60	μs
V_{ol_stbyok}	STBY_OK low output voltage	$V_{STBY} = 1\text{ V}$ $I_{stbyok} = 1\text{ mA}$	-	-	0.4	V

5 Functional description

5.1 General function

The L9758 is equipped with 9 linear voltage regulators. A buck boost switch mode power supply as pre regulator for the 7 main regulators is used to reduce the power consumption in the system.

Two standby regulators can be used to bias the system on off-mode. These two regulators are equipped with an independent bandgap voltage reference. The current consumption of these two linear regulators is specified to be less than 120 μA in OFF state. If these standby functions are not used the current consumption on the battery can be reduced by not connecting the VBAT. Under this condition the device enters immediately in the run mode, the pin PSU_REN loses his function. The quiescent current on the VBAT_SW can be reduced to maximum 10 μA with 12 V battery voltage in off mode. The main regulators can be activated with the IGN input. With an external resistor higher than 10 k Ω in series to the IGN pin a battery compliant signal can be used. In the functional block diagram (see [Figure 2](#)) a resistor value of 51 k Ω is used together with a 100 nF capacitor for noise robustness on IGN.

5.2 Switching pre-regulator

The switching pre-regulator is a buck or a buck-boost current control mode regulator. The optional boost operation for low battery conditions can be selected connecting external logic level low side NCH FET and an external diode in series to the inductor.

The external parts required to complete the switching regulator are an inductor, recirculation diode and input and output filtering capacitor. The compensation network is inside the device.

With a constant switching frequency of 350 kHz, the pre-regulator controls the output voltage (the voltage at the VB and FDBK pins) to the limits stated in the electrical characteristics table varying the duty cycle. The 350 kHz are related to $R_{EXT} = 10 \text{ k}\Omega$ (see [Section 5.8](#)).

At low battery voltages, in buck configuration, the pre-regulator runs with the duty cycle up to 100%. In buck-boost configuration normally it runs at 350 kHz but for a limited range of input voltage it could enter in pulse skipping mode to control the output voltage.

A soft start function is implemented reducing the current limitation during the power-up phase.

5.3 VDD5, VDDL and VCORE linear regulators

The VDD5 output is a fully integrated low drop out regulator. The V_{DDL} and V_{CORE} supplies will be implemented via an external N-channel pass MOS, with the control being internal to the IC. If the pass MOS is not used, two low current (max 30 mA) regulators are available connecting directly VDDL_FDBK to VDDL_DRV and VCORE_FDBK to VCORE_DRV with a resistor divider. The output of the pre-regulator is used as the source of these supplies.

V_{DD5} is a fixed 5 V nominal output, while V_{DDL} and V_{CORE} are programmable.

The V_{DDL} voltage is selectable with the VPROG3 pin: 2.5 V if connected to GND and 3.3 V if left open (an internal pull-up is present). V_{CORE} voltage is programmable connecting an external resistor divider at the feedback pin (VCORE_FDBK).

Once programmed to a value at power-up, this value cannot change during the power cycle. Purposely the system runs at a single fixed value for V_{DDL} and V_{CORE} for the life of the product.

All the linear regulators start with a controlled slew rate when the pre-regulated voltage reaches V_{DDL_ENUP} threshold as indicated in the electrical characteristics table. All the linear regulators are short circuit protected with a limited current.

5.4 Tracking regulators

Four low drop-out tracking regulators (VSA, VSB, VSC and VSD) are supplied by the output of the switching pre-regulator. They track the output voltage of the VDD5 linear regulator with the accuracy as specified in the electrical characteristic table.

The VSA regulator also tracks an external voltage reference (TRACK_REF pin) and the tracking voltage is selected by the REF_SEL pin.

If REF_SEL is tied High (5 V) then V_{TRK_REF} is tracked. If REF_SEL is left open then V_{DD5} is tracked. There is an internal pull-down on REF_SEL.

The tracking supplies are intended to drive loads that are external to the ECU so they are short circuit protected with the current limited. The outputs of the tracking regulators also withstand short circuit to the battery.

A short circuit to GND, continuous or intermittent on one tracking supply will not affect any other supply, including the preregulator output voltage V_B . In addition to these requirements, all sensor supplies shall be capable of operating with up to a 15 μ F load on the supply line. This load may be present during initial startup, or be applied after the supply has been powered up. In either case, the application of this load shall not cause the tracking regulators to be permanently disabled.

VSB, VSC and VSD regulators can be disabled with VS_EN pin.

5.5 VKAM and VSTBY linear regulators

These two outputs are fully integrated low quiescent current low drop out regulators. The input VBAT is used as the source of these supplies. These outputs are operational during both standby and run mode; these are the only outputs operational during standby (V_{BAT} not present).

The VKAM regulator has two programmable levels: 1.0 V (VPROG1 pin connected to GND) or 1.5 V (if this pin is left open, an internal pull-up is present).

The V_{STBY} regulator has two programmable levels: 2.6 V (VPROG2 pin connected to GND) or 3.3 V (if this pin is left open, an internal pull-up is present).

The STBY_OK pin indicates when the V_{STBY} is out of range (voltage below the threshold indicated in the electrical characteristic table). Once driven low it should stay low for a minimal amount of time allowing external circuitry to latch.

5.6 RESET monitors

RST5 is the reset signal tied to the V_{DD5} supply. This is an open collector active low signal that pulls low when V_{DD5} is out of range.

RSTL is the reset signal for the V_{DDL} supply. This is an open collector active low signal that pulls low when V_{DDL} is out of range. RST5 and RSTL are also driven low when STBY_OK pin is driven low, regardless of the status of V_{DD5} and V_{DDL} .

Reset Delay is the time duration from when the output (V_{DD5} or V_{DDL}) is within range to when the reset pin (RST5 or RSTL) is released. RST5 and RSTL use separate timers. This delay is programmable via an external resistor connected to RST_TIM pin. A value of 4.7 k Ω corresponds to 1 ms and 47 k Ω to 10 ms. All values in between are linear approximated. The timer delay is common however the attack and release times are only dependant on the condition of the respective supplies (V_{DD5} or V_{DDL}).

5.7 Thermal protection

The tracking regulators incorporate thermal limit with shutdown. When the junction temperature reaches the shutdown threshold, if there is a tracking regulator in current limitation, it switches off and all the other regulators stay on. When the temperature decreases the regulator restarts. The over temperature shutdown has a hysteresis to avoid thermal pumping.

5.8 Reference current

The L9758 provides a DC voltage at the REXT pin. An external resistor to ground creates a reference current which is mirrored internally for use in the device.

The reference current is used to supply all the analog blocks and to charge and discharge an integrated capacitor to generate a 5 MHz clock for the switching functionality.

Figure 3. Current reference generator

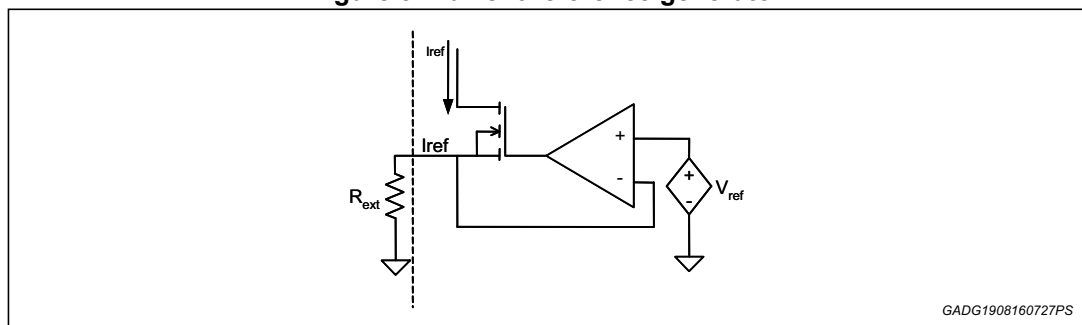

The circuit is designed for a 10 k Ω resistor. For all affected parameters, this resistor value is mentioned in the electrical characteristics section.

6 Operating modes

There are two modes of operation of the power supply: standby and run mode. However during RUN mode, there are three input voltage regions: low voltage, normal voltage and high voltage. A brief definition and description of each of these operating regions is described below.

6.1 Standby mode

STANDBY mode is defined by the following conditions:

- VBAT is within the required voltage range
- VBAT_SW may or may not be present
- IGN is in the OFF state
- PSU_EN is not asserted by the microprocessor

During standby mode, all functions are shutdown except the two standby supplies, VKAM and VSTBY, and the circuitry monitoring IGN and PSU_EN. During standby mode, current consumption is minimized. The standby functions are powered from VBAT.

There is no currents drawn from VBAT_SW or any other input except those required to perform the standby functions. Outputs, other than IGN_ON are disabled, sourcing nor sinking current.

6.2 Run mode

RUN mode is defined by the following conditions:

- VBAT is within the required range
- VBAT_SW is within the required range
- Either IGN is in the Run state and/or PSU_EN is in the active state

During RUN mode, all functions can be enabled. All functions listed above, with the exception of the standby functions, are powered by VBAT_SW.

If VBAT is not present, the circuit is fully running with the exception of PSU_EN and the standby functions (VKAM and VSTBY). In this condition the entry into the RUN MODE can only be performed by the IGN pin and the circuit is kept running until IGN pin is pulled low.

6.2.1 Entry into RUN mode

RUN mode is entered when at least one of the two signals IGN_SW or PSU_EN goes in the active state. These two signals may be applied in any order or simultaneously.

When the IGN input is valid, the active low IGN_ON signal is asserted.

The design of VDD5, VDDL and VCORE regulators limits the slew rate of the output voltages during the start-up as indicated in the electrical characteristic table and ensures that V_{DD5} is always greater than V_{DDL} and V_{CORE} .

As indicated in [Figure 4](#), the switching regulator starts first with soft start control or reduced current limitation. When the VB voltage reaches the VDDL_ENUP threshold all the linear regulators start with controlled slew-rate. The slew-rate control is done controlling the slew

rate of the common voltage reference so the slew is different for each regulator because all start together and reach the steady-state at the same time but with different voltage levels.

6.3 Power down

The power down sequence starts when both IGN and PSU_EN signal are low. In this phase there is no control of the linear regulator output voltages. The falling slew-rate is defined from load currents and load capacitors. A voltage comparator controls VDDL voltage and ensures that the VDDL supply voltage will drop below 2V before initiating a new power-up sequence.

Figure 4. Power up/down sequence

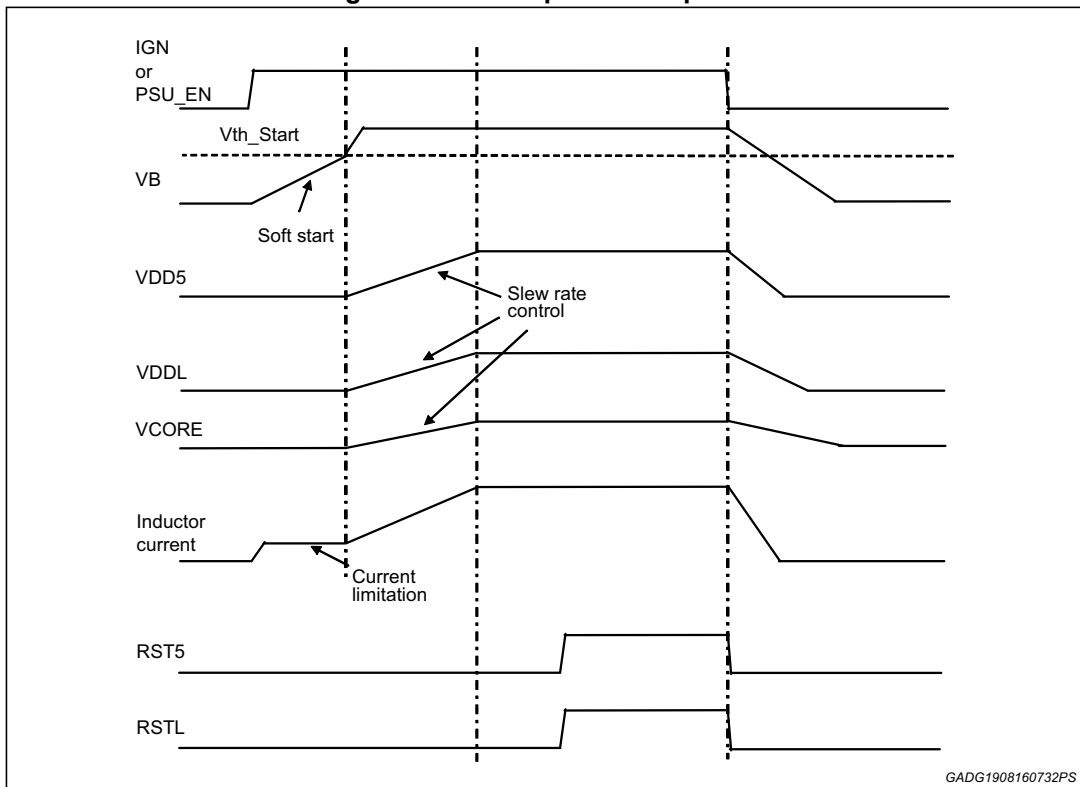

GADG1908160732PS

6.4 Low voltage operation

When L9758 is up and running it is fully operational with the VBAT and VBAT_SW pin voltages down to V_{LVI_LOW} . When L9758 is up and running and the supply voltages are less than 5.5 V and are greater than or equal to V_{LVI_LOW} if the boost option is used the device is fully operational. If only the buck regulator is used the L9758 operates as follows:

- Switching regulator runs at 100% duty cycle;
- VKAM and VSTBY regulators are fully operational;
- VDDL fully operational;
- VCORE fully operational;
- VDD5 out of range with output voltage no less than 3.2 V;
- Tracking regulators out of range with output voltages no less than 3.2 V;
- Reset monitor RST5 and RSTL fully operational, with reset at RST5 pin is allowed.

6.5 High voltage operation

The L9758 is fully operational during jump start when the battery is temporarily replaced with a higher voltage source to aid starting the engine (26.5 V for 1 minute). The L9758 is fully operational during positive battery transient such as load dump (40 V maximum voltage with durations of up to 400 ms).

7 Package information

In order to meet environmental requirements, ST offers these devices in different grades of ECOPACK® packages, depending on their level of environmental compliance. ECOPACK® specifications, grade definitions and product status are available at: www.st.com. ECOPACK® is an ST trademark.

7.1 PowerSO-36 package information

Figure 5. PowerSO-36 package outline

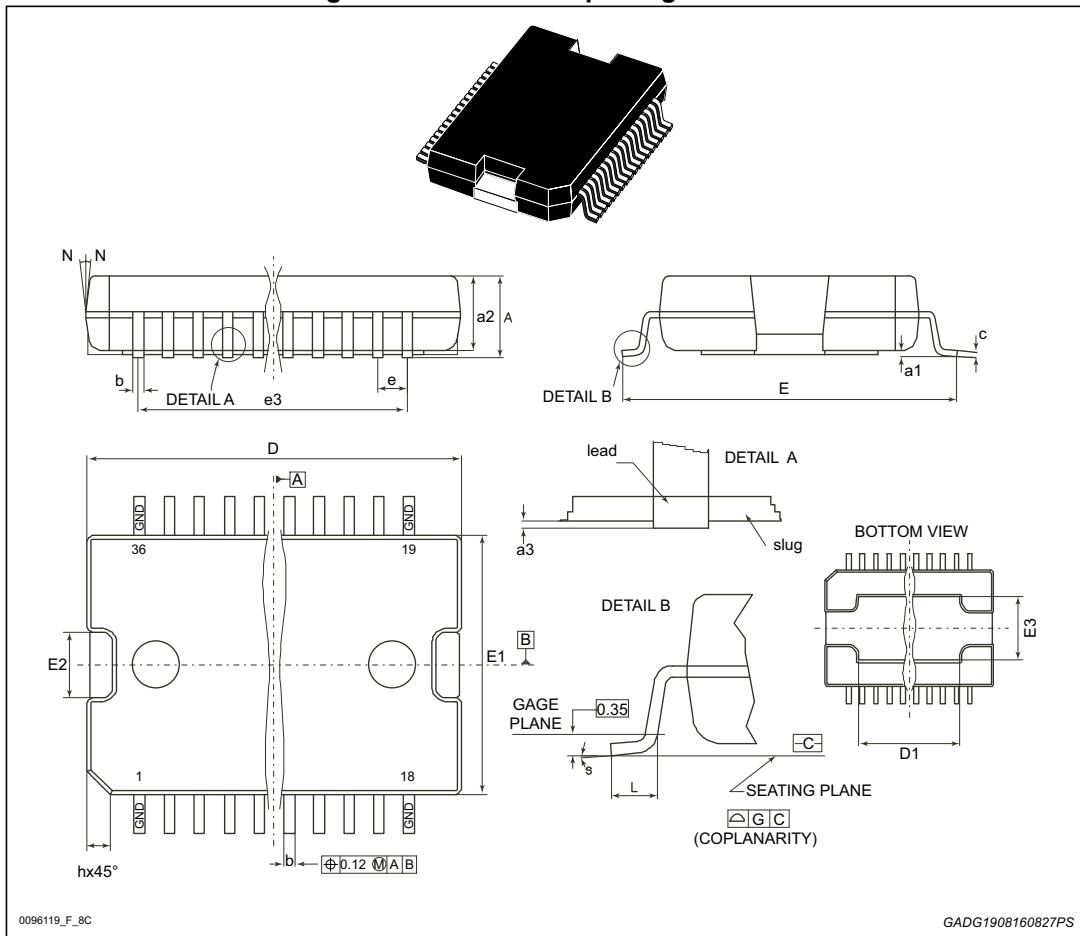

Table 20. PowerSO-36 package mechanical data

Ref	Dimensions					
	Millimeters			Inches ⁽¹⁾		
	Min.	Typ.	Max.	Min.	Typ.	Max.
A	-	-	3.60	-	-	0.1417
a1	0.10	-	0.30	0.0039	-	0.0118
a2	-	-	3.30	-	-	0.1299
a3	0	-	0.10	-	-	0.0039
b	0.22	-	0.38	0.0087	-	0.0150
c	0.23	-	0.32	0.0091	-	0.0126
D ⁽²⁾	15.80	-	16.00	0.6220	-	0.6299
D1	9.40	-	9.80	0.3701	-	0.3858
E	13.90	-	14.5	0.5472	-	0.5709
E1 ⁽²⁾	10.90	-	11.10	0.4291	-	0.4370
E2	-	-	2.90	-	-	0.1142
E3	5.80	-	6.20	0.2283	-	0.2441
e	-	0.65	-	-	0.0256	-
e3	-	11.05	-	-	0.4350	-
G	0	-	0.10	0	-	0.0039
H	15.50	-	15.90	0.6102	-	0.6260
h	-	-	1.10	-	-	0.0433
L	0.8	-	1.10	0.0315	-	0.0433
N	10° (max)					
s	8° (max)					

1. Values in inches are converted from mm and rounded to 4 decimal digits.
2. "D and E1" do not include mold flash or protusions. Mold flash or protusions shall not exceed 0.15 mm (0.006"). Critical dimensions are "a3", "E" and "G"..

8 Revision history

Table 21. Document revision history

Date	Revision	Changes
12-Dec-2007	1	Initial release.
17-Nov-2010	2	Updated <i>Section 1: Pins configuration</i> . Updated <i>Figure 2: Functional block diagram</i> . Updated <i>Section 3: Operating conditions</i> . Updated <i>Table 7: General DC characteristics</i> and <i>Table 12: VCORE linear regulator</i> . Added <i>Section 5.1: General function</i> . Updated <i>Section 5.2: Switching pre-regulator</i> , <i>Section 5.6: RESET monitors</i> and <i>Section 5.8: Reference current</i> . Updated <i>Section 5.3: VDD5, VDDL and VCORE linear regulators on page 21</i> .
23-Nov-2010	3	Update <i>Table 10, Table 11, Table 12, Table 13</i> and <i>Table 14</i> .
20-Sep-2013	4	Updated disclaimer.
06-Sep-2016	5	Updated: – Title in cover page (added 'Automotive'); – <i>Features on page 1</i> (added 'AEC-Q100 qualified' and car icon); – <i>Table 1: Device summary on page 1</i> . – <i>Table 7: General DC characteristics on page 12</i> – <i>Package information on page 27</i> .

IMPORTANT NOTICE – PLEASE READ CAREFULLY

STMicroelectronics NV and its subsidiaries (“ST”) reserve the right to make changes, corrections, enhancements, modifications, and improvements to ST products and/or to this document at any time without notice. Purchasers should obtain the latest relevant information on ST products before placing orders. ST products are sold pursuant to ST’s terms and conditions of sale in place at the time of order acknowledgement.

Purchasers are solely responsible for the choice, selection, and use of ST products and ST assumes no liability for application assistance or the design of Purchasers’ products.

No license, express or implied, to any intellectual property right is granted by ST herein.

Resale of ST products with provisions different from the information set forth herein shall void any warranty granted by ST for such product.

ST and the ST logo are trademarks of ST. All other product or service names are the property of their respective owners.

Information in this document supersedes and replaces information previously supplied in any prior versions of this document.

© 2016 STMicroelectronics – All rights reserved