

REVISION			
REV.	DESCRIPTION	DATE	APPROVED

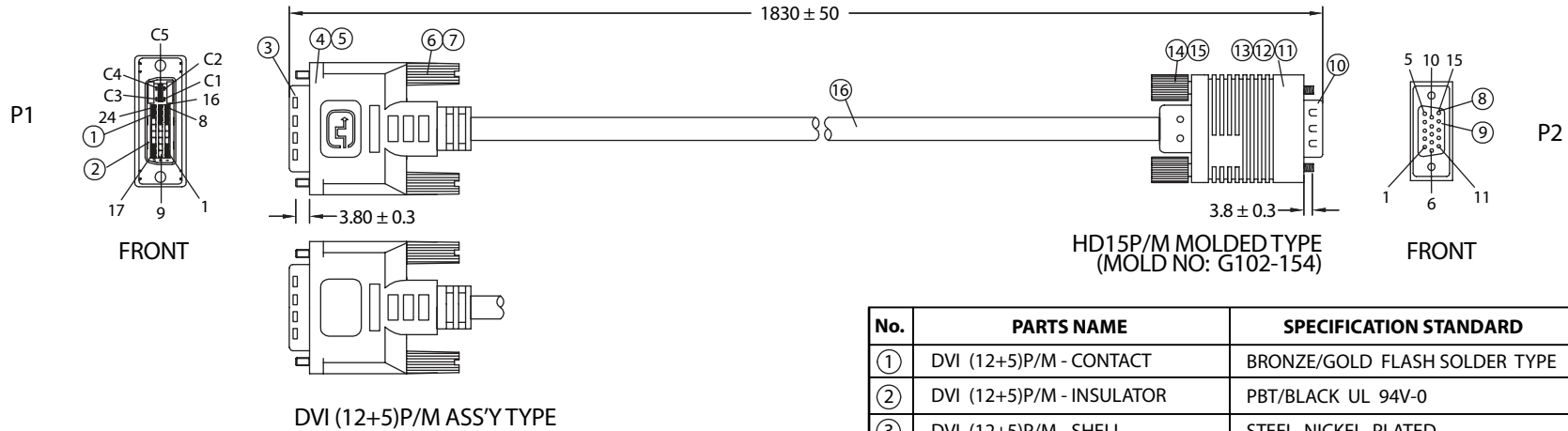

DVI (12+5)P/M ASS'Y TYPE

HD15P/M MOLDED TYPE  
(MOLD NO: G102-154)

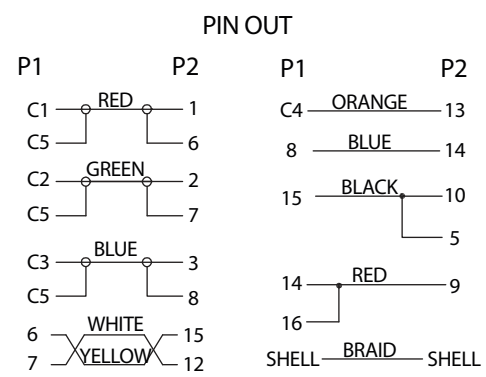
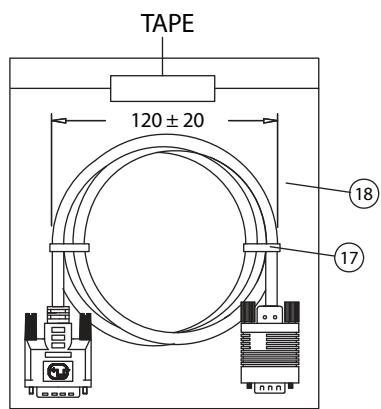

**NOTES:**

- CABLE: UL20276  
(28AWG+SP+FOIL)x3C+28AWGx4C+28AWGx1P+MYLAR+FOIL+BD  
OUTER JACKET BEIGE, OD: 6.5 ± 0.2  
PRINTING: "E166307 AWM 20276 28AWG 80°C 30V VW-1  
LOW VOLTAGE COMPUTER CABLE"
- CONNECTORS: DVI(12+5)P/M-HD15P/M
- HOOD: ASS'Y TYPE, COLOR: BEIGE
- CABLE ELECTRICAL TEST:
  - <1>.100% OPEN SHORT & MISS WIRE TEST
  - <2>.INSULATION RESISTANCE: DC400V 10M ohm MIN.
  - <3>.CONDUCTOR RESISTANCE: 3 ohm MAX.
- PACKING: 1PC/POLYBAG

No.	PARTS NAME	SPECIFICATION STANDARD	QTY
①	DVI (12+5)P/M - CONTACT	BRONZE/GOLD FLASH SOLDER TYPE	17
②	DVI (12+5)P/M - INSULATOR	PBT/BLACK UL 94V-0	1
③	DVI (12+5)P/M - SHELL	STEEL NICKEL PLATED	1
④	DVI (12+5)P/M - CAN	STEEL TIN PLATED	1
⑤	DVI (12+5)P/M - COVER	45P PVC/COLOR: BEIGE	1
⑥	THUMB SCREW	#4-40 2.8x45, NICKEL PLATED	2
⑦	SCREW-MOLD	35P PVC/COLOR: BLACK	2
⑧	HD15P/M - CONTACT	BRASS GOLD FLASH SOLDER TYPE	15
⑨	HD15P/M - INSULATOR	PBT/BLACK UL 94V-0	1
⑩	HD15P/M - SHELL	STEEL NICKEL PLATED	1
⑪	HD15P/M - INNER MOLD	PE NATURAL	1
⑫	HD15P/M - COPPER FOIL	WIDTH: 28mm	1
⑬	HD15P/M - OUTER MOLD	45P PVC/COLOR: BEIGE	1
⑭	HD15P/M - THUMB SCREW	UNC #4-40 Ø4xL50, NICKEL PLATED	2
⑮	HD15P/M - SCREW-MOLD	35P PVC/COLOR: BLACK	2
⑯	CABLE DVI 12+5 UL20276	L03010ABK01A	1
⑰	MINI TIE	PE/BLACK	2
⑱	POLYBAG	PE/0.8x160x200	1

Dim range (mm)	Tolerance +/- (mm)	Qualtek Electronics Corp. WCI DIVISION		
		Part Number: 1321012-06		RoHS Compliant
0-1	0.15	Description: DVI (12+5)P/M - HD15P/M		
1-6	0.20			
6-18	0.30			
18-50	0.50			
50-120	0.70			
120-250	0.90	Drawn / Date	Checked / Date	Approved / Date
250-500	1.20	B.Grubb 01-05-07	01-05-07	JJH / 01-05-07