

HODVTEC-31618-000

SHT 1.1

NOTES:

1. A POSITIVE GOING VOLTAGE AT TERMINAL 2, RELATIVE TO TERMINAL 1, CAUSES A DECREASE IN PRESSURE AT THE SOUND OUTLET.

2. LOCATED FROM TWO SURFACES FOR CUSTOMER CONVENIENCE. ONLY APPLICABLE FROM ONE SURFACE, NOT TO BE USED TOGETHER. HORIZONTAL LOCATION FOR TERMINAL CENTERED TO $\pm 0,17$ [.007].

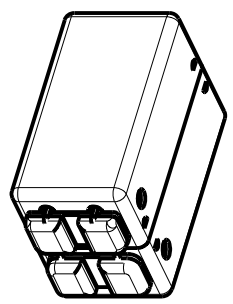
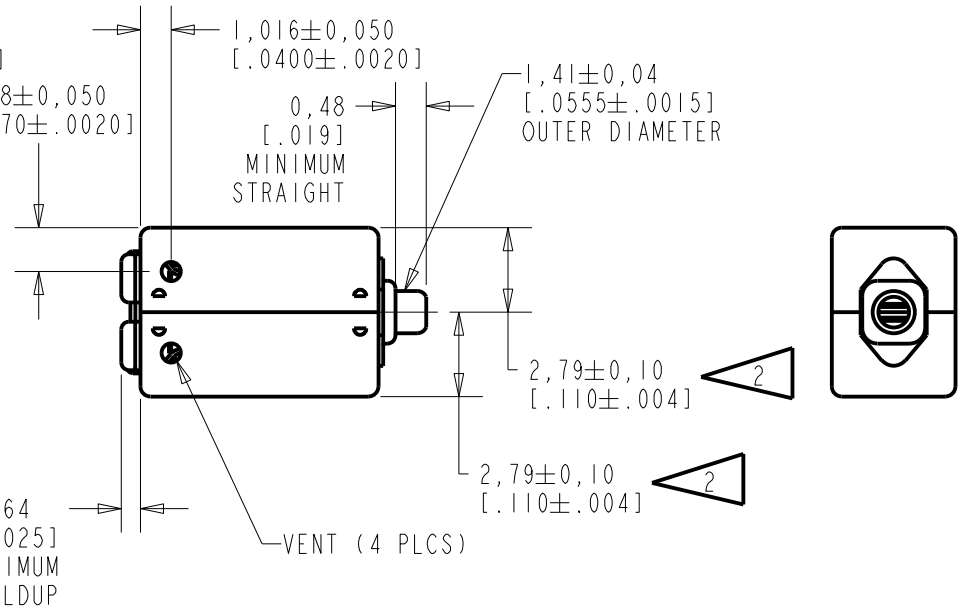
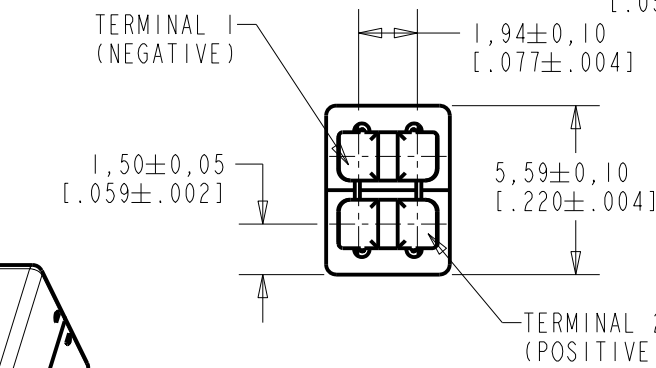
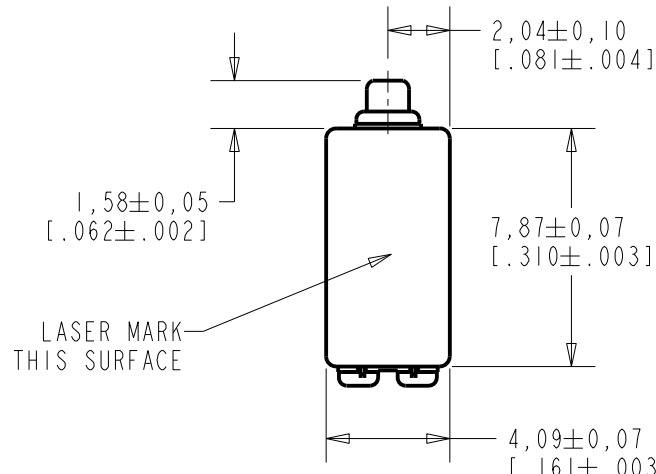

NOMINAL WEIGHT
.71 GRAMS

DIMENSIONS IN MILLIMETERS [INCHES]

Revision	C.O. #	Implementation Date	RELEASE LEVEL	REVISION
A	C10112996	2-6-12	Active	A

SCALE:	4:1	DR. BY	DATE
DO NOT SCALE DRAWING		KL	2-6-12
TITLE:	RECEIVER	GJP	2-6-12
	HODVTEC-31618-000	APP. BY	DATE
	SHT 1.1	GJP	2-12-12

KNOWLES ELECTRONICS
ITASCA, ILLINOIS U.S.A.

THE HODVTEC-31618-000 IS A PAIR OF BALANCED ARMATURE RECEIVERS WITH BACK VENT.

NO DAMPING

HODVTEC-31618-000
SHEET 2.1

NOTE: SPECIFICATIONS FOLLOWED BY AN ASTERISK (*) ARE 100% TESTED.

CONSTANT VOLTAGE DRIVE CONDITIONS

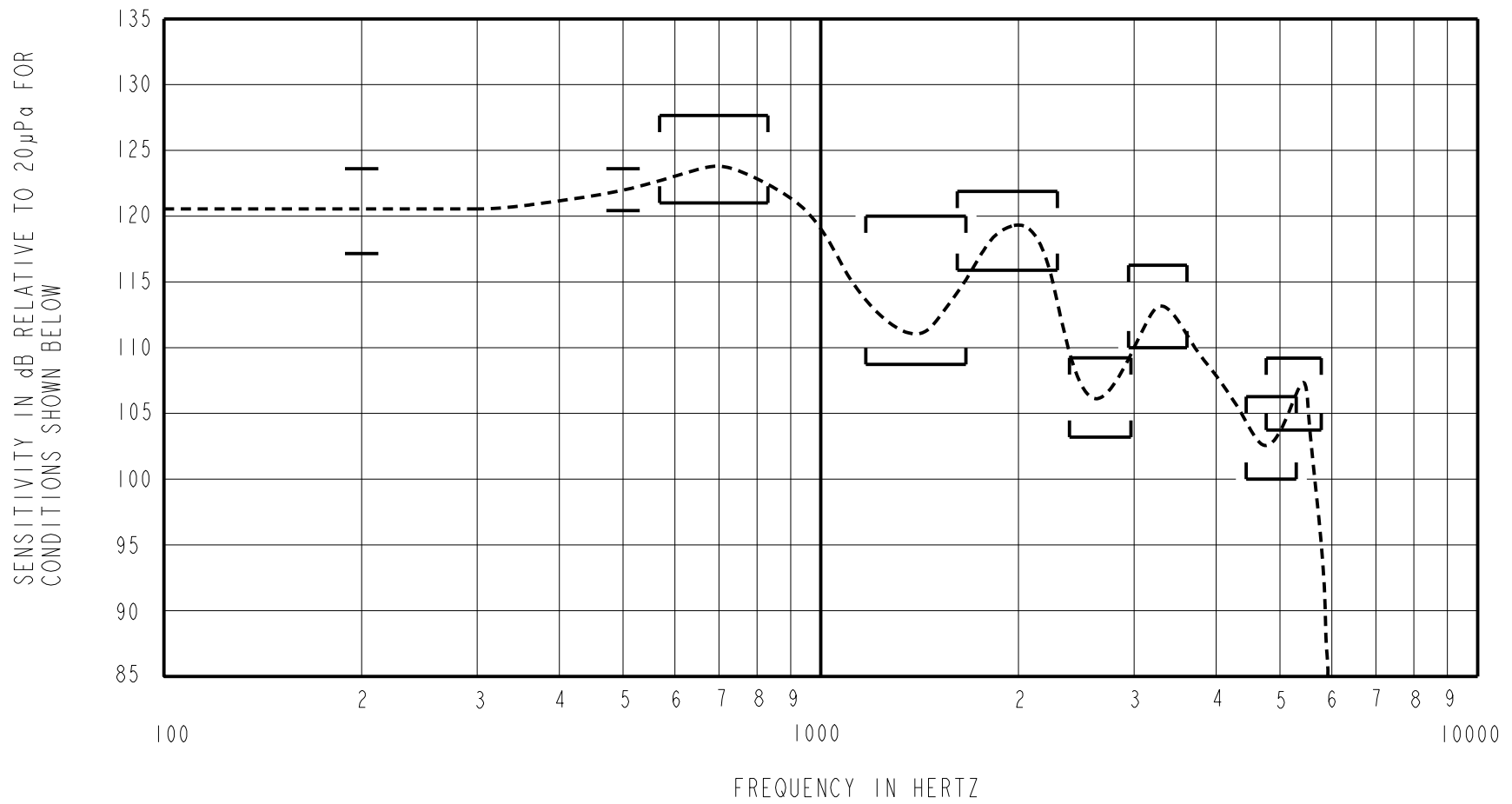

ACOUSTICAL

SENSITIVITY*
DEVICE WILL PRODUCE THE SPL LISTED BELOW UNDER TEST CONDITIONS DESCRIBED IN TABLE 3. NOMINAL SENSITIVITY AT 500 Hz IS dB RELATIVE TO 20µPa. ALL OTHER VALUES IN dB RELATIVE TO THE SENSITIVITY AT 500 Hz.

FREQUENCY (Hz)	MINIMUM	NOMINAL	MAXIMUM
200	-4.5	-1.5	+1.5
500	-1.5	122.0	+1.5
560-840	-0.5	+2.5	+5.5
1220-1700	-13.0	-10.0	-7.0
1650-2300	-5.5	-2.5	+0.5
2415-2985	-19.0	-16.0	-13.0
2960-3640	-12.0	-9.0	-6.0
3845-4755	-18.0	-15.5	-13.0
3524-4324	-22.0	-19.0	-16.0

TABLE 1

TOTAL HARMONIC DISTORTION*
DEVICE WILL NOT EXCEED TOTAL HARMONIC DISTORTION LEVELS LISTED BELOW.

FREQUENCY (Hz)	AC DRIVE (V rms)	DC BIAS (mA)	LIMIT (%)
1/3 PEAK	0.084	0	5
1/2 PEAK	0.084	0	5
1/2 PEAK	0.168	0	10

TABLE 2

TEST CONDITIONS

NOMINAL SOURCE VOLTAGE	0.084 V rms, TO DELIVER 0.70 mVA AT 500 Hz
SOURCE IMPEDANCE	<1 Ohm
TUBING	8mm X 1mm ID + 28mm X 1.5mm ID EAR HOOK SIMULATOR + 25mm X 2mm ID TUBE + 18mm X 3mm ID TUBE
COUPLER CAVITY	2 cm ³ , SIMULATED ANSI S3.7 TYPE HA-3 (IEC 60318-5)

TABLE 3

ELECTRICAL

DC RESISTANCE	8.6 OHMS ± 10% *
IMPEDANCE @ 500 Hz	25 OHMS ± 15% *
INDUCTANCE @ 500 Hz	7.9 mH ± 15% *
CAPACITANCE @ 10 MHz	15 pF TYPICAL

TABLE 4

ISOLATION: CASE WILL BE ELECTRICALLY ISOLATED FROM THE COIL CIRCUIT.*

MECHANICAL

PORT LOCATION: 12S

SOLDER TYPE: SAC305

TEMPERATURE

OPERATING: SENSITIVITY WILL NOT VARY MORE THAN
+1/-3 dB FROM -17°C TO 63°C

STORAGE: -40°C TO 63°C

KNOWLES ELECTRONICS
ITASCA, ILLINOIS U.S.A.

Revision	C.O. #	Implementation Date	RELEASE LEVEL	REVISION
A	C10112996	2-6-12	Active	A

WHEN TEST LIMITS ARE USED TO ESTABLISH INCOMING INSPECTION ACCEPTANCE/REJECTION CRITERIA, CORRELATION OF TEST EQUIPMENT WITH KNOWLES IS ALSO REQUIRED FOR ELIMINATION OF EQUIPMENT AND TEST METHOD VARIATION		DR. BY	DATE
TITLE: RECEIVER PERFORMANCE SPECIFICATION		KL	2-6-12
		GJP	2-6-12
HODVTEC-31618-000 SHT 2.1		APP. BY	DATE
		GJP	2-12-12