

Data Sheet	DMM-4026-B-I2S-EB-R
------------	---------------------

PUI Audio is proud to release a line of high-fidelity MEMS wide-band microphones that cover the entire audio band from 20 Hz up to 18 kHz—and up to 20 kHz on some models—while featuring an industry-best consistency of  $\pm 1$  dB across the entire frequency response.

Quickly test and prototype the I<sup>2</sup>S **DMM-4026-B-I2S-R** with this evaluation board. Solder pads make wiring to the evaluation board quick-and-easy!

### Specifications

Parameters	Condition	Values	Units
Directivity	Omnidirectional		
Data Format	I <sup>2</sup> S 24-bit data size with 18-bit precision, 32-bit word size		
Sensitivity	1 kHz @ 50cm with 94 dB source 0 dB=1V/Pa	-26 $\pm$ 1	dB
Rated Voltage	-	1.8	VDC
Operating Voltage Range	-	1.5 to 3.6	VDC
Supply Current	Normal Mode	820 ~ 1000	$\mu$ A
	Sleep Mode (clock off)	5	$\mu$ A
Signal-to-Noise Ratio	1kHz, 94 dB input, A-weighted	64	dB
Frequency Range	20~20,000		Hz
Total Harmonic Distortion (typical)	110 dB @ 50cm, 1 kHz acoustic source	1%	-
Startup Time	Sensitivity reaching 90% of listed value from initial power-up	20	mS
	From Sleep Mode	20	mS
	From Normal Mode to Sleep Mode	20	mS
Input Clock Frequency	Normal Mode	2.048 ~ 4.096	MHz
	Sleep Mode	320	kHz
Clock Jitter	Long Term RMS	500	pS
Load Capacitance	-	140	pF
Pass Band	Fs=48 kHz	18	kHz
Pass Band Attenuation	-	0.5	dB
Environmental Compliances	RoHS/Halogen Free		
Power Supply Rejection	100 mVpp Square Wave @ 217 Hz, A-weighted	-86	dBFS
Operating Temperature	-40 ~ +100		°C
Storage Temperature	-40 ~ +125		°C

## Measurement Method

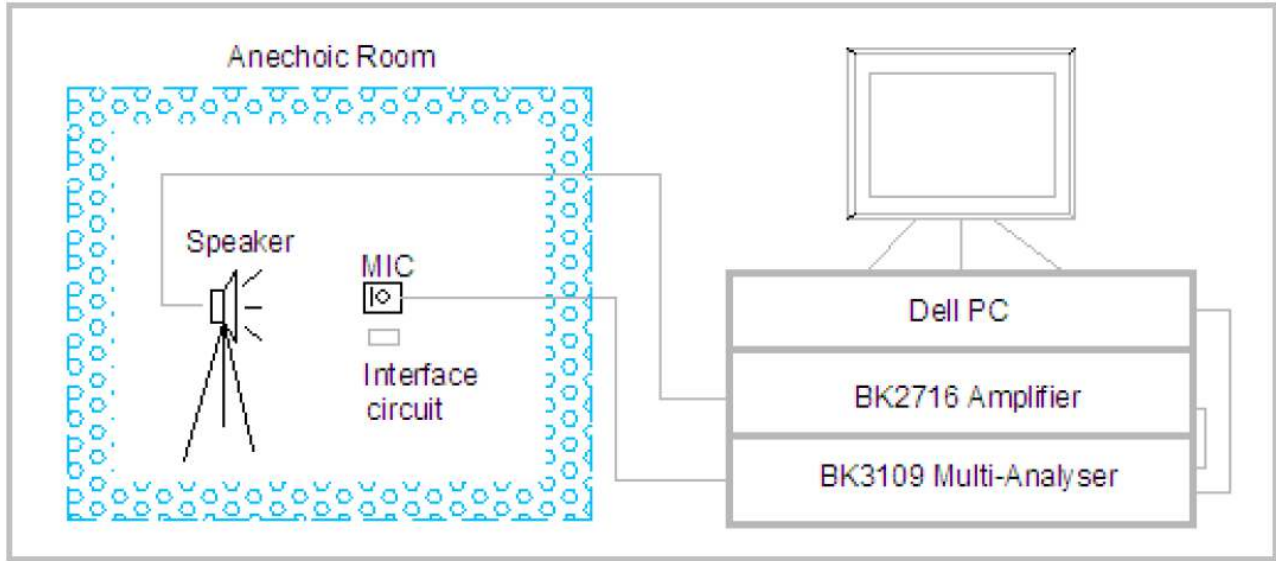

## Measurement Interface Circuit

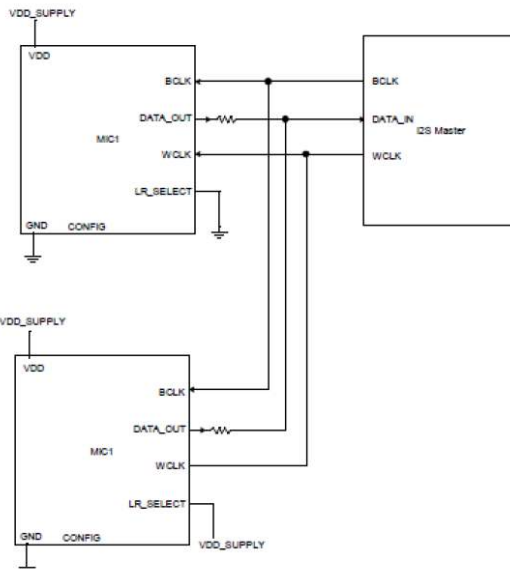
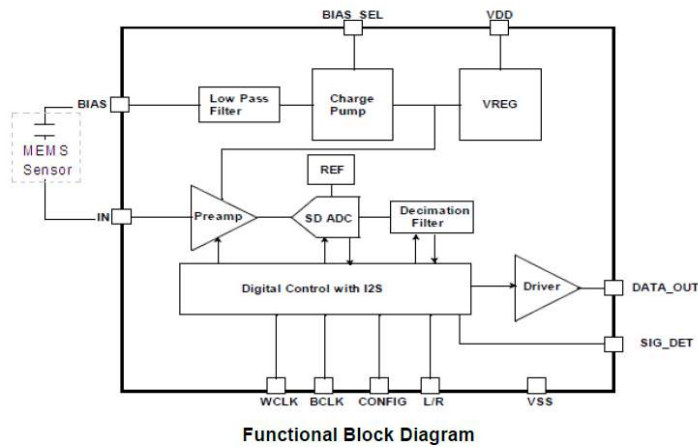

Interface diagram between I2S Master and 2 Microphones

## Digital Interface Specifications

In order to properly use this microphone, the I2S converter must support a 32-bit word size for mono operation and 64-bit word size for stereo operation with two microphones. Each microphone outputs 24-bit data with 18-bit precision. Six bits are null (0) value.

Parameters	Symbol	Condition	Value			Units
			MIN	Typical	MAX	
BCLK Frequency	BCLK	-	-	3.072	12.288	MHz
BCLK Duty Cycle	-	-	45	-	55	%
Data Valid	TDV	-	-	-	18	nS
WCLK Hold Time	THWCLK	Two mic mode	32 (1/BCLK)	-	-	nS
		Array mic mode	20	-	-	nS
WCLK Setup Time	TSWCLK	-	20	-	-	nS

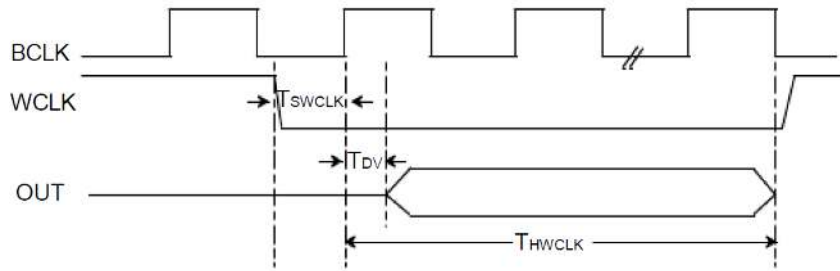

Interface timing diagram for two microphone Mode

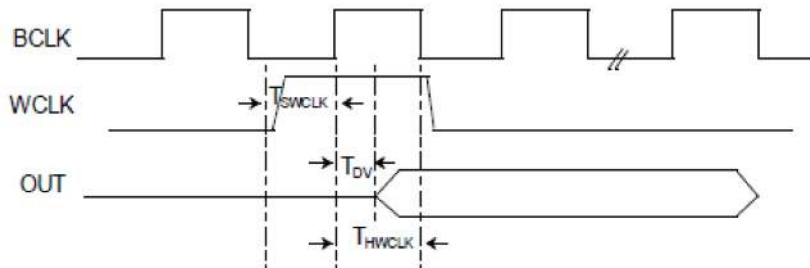

Interface timing diagram for Array microphone Mode

## Typical Frequency Response (Microphone spaced 50cm from 94 dB acoustic source)

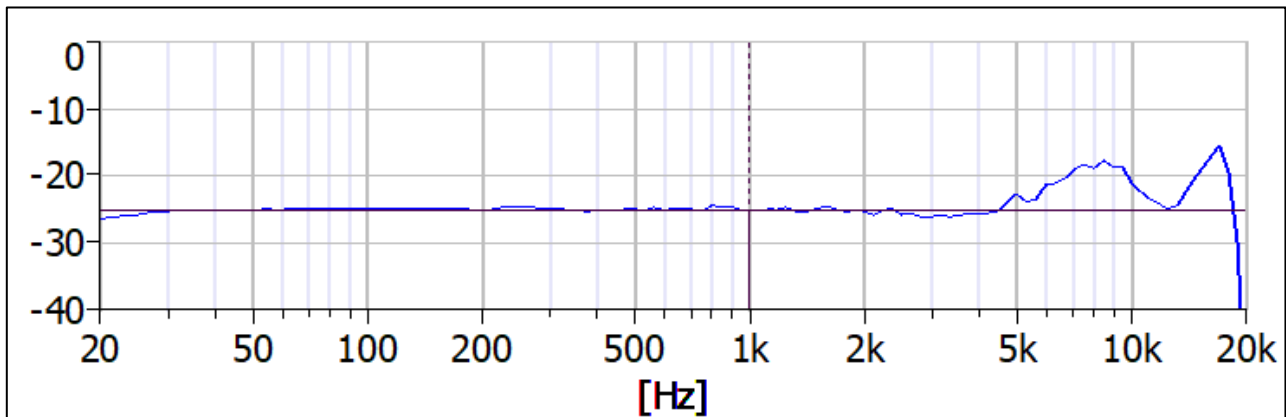

## Reliability Testing

Type of Test	Test Specifications
Simulated Reflow (Without Solder)	Samples for qualification testing require 3 passes 260±5 °C reflow solder profiles. 2 hours of setting time is required between each reflow profile test.
Static Humidity	Precondition at +25°C for 1 hour. Expose to +85°C with 85% relative humidity for 1000 hours. Dry at room ambient for 3±1 hour before taking final measurement.
Temperature Shock	Each cycle shall consist of 30 minutes at -40°C, 30 minutes at +125°C with 5 minutes transition time. Test duration is for 30 cycles, starting from cold to hot temperature.
ESD Sensitivity	Perform ESD sensitivity threshold measurements for each contact according to MIL-STD-883G, Method 3015.7 for Human Body Model. Identify the ESD threshold levels indicating passage of 8000V Human Body Model.
Vibration Test	Vibrate randomly along three perpendicular directions for 30 minutes in each direction, 4 cycles from 20~2000 Hz with a peak acceleration of 20 Gs.
Shock Test	Subject samples to half-sine shock pulses (3000±15% Gs for 0.3ms) in each direction, for a total of 18 shocks.
Drop Test	Drop samples from 1.5m height onto a steel surface, total 18 times and inspected for mechanical damage.
Operation Life	Subject samples to +125°C for 168 hours under full maximum rated voltage.

**Microphone frequency response and sensitivity shall not deviate more than ±3 dB.**

## Dimensions

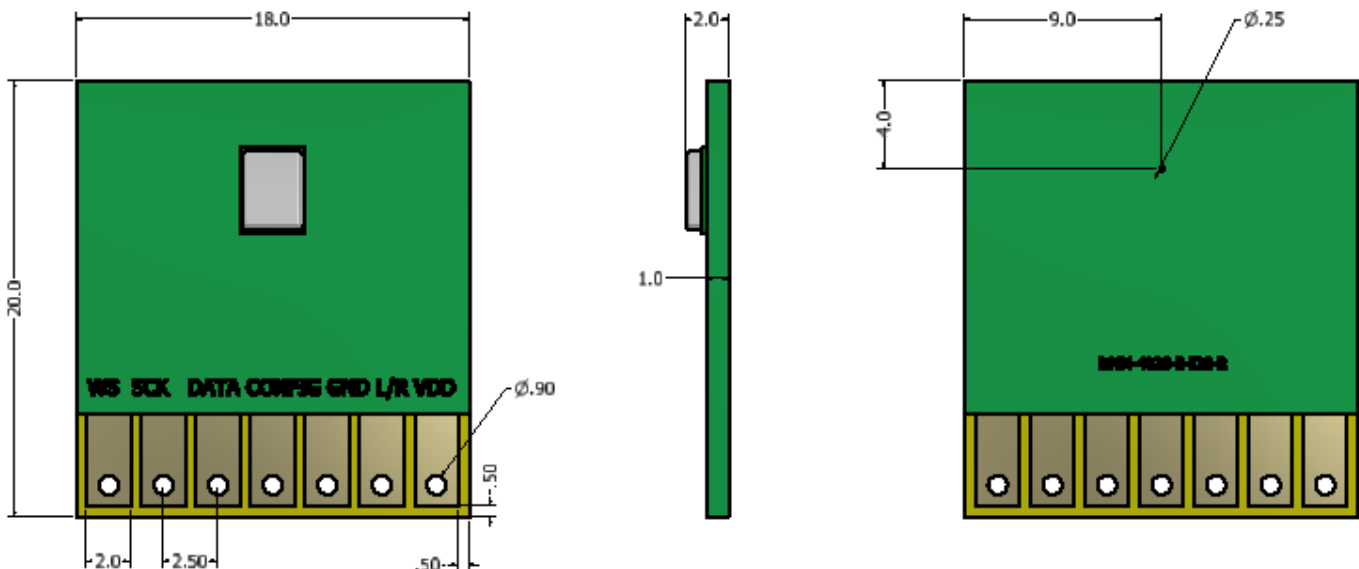

**Specifications Revisions**

<b>Revision</b>	<b>Description</b>	<b>Date</b>
-	Released from Engineering	1/31/2020
A	Added I2S data information	5/26/2021

Note:

- Unless otherwise specified:
  - All dimensions are in millimeters.
  - Default tolerances are  $\pm 0.5\text{mm}$  and angles are  $\pm 3^\circ$ .
- Specifications subject to change or withdrawal without notice.