

Features and Benefits

- Four grades of magnetic materials
- Cost effective design
- High resistance to demagnetization
- Operation from -40°C to 125°C
- Tough environmental endurance
- Very resistant to chipping
- Wide range of pole counts



Molded Target Magnet

Physical Properties of Magnetic Material

Table 1.1

Characteristic	Value	Units
Tensile Strength	6500	PSI
Flexural Strength	9750	PSI
Flexural Modulus	1.3 X 10 ⁶	PSI
Continuous Service Temperature	100	°C

Magnetic Properties

Table 1.2

Characteristic	Magnalox 300	Neobond 12M	Neobond 30M	Neobond 32P	Units
Remanence (B _r)	1370	2500	4000	4300	Gauss
Coercive Force (H _c)	1180	2400	3250	2500	MGOe
Energy Product (BH _{MAX})	0.40	1.3	3.1	3.2	Oersted
Intrinsic Coercive Force (H _{ci})	2300	7500	7000	6900	Oersted
Reversible Temperature Coefficient	-0.2	-0.35	-0.4	-0.4	/°C
Specific Gravity	3.5	4.0	4.7	4.45	---

Pole Counts

Alternating north and south magnetic poles are symmetrically located on the outer diameter for radial sensing.

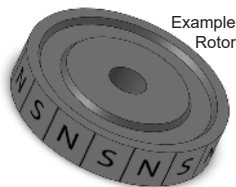

Note: (N)orth/(S)outh markings are for illustration and do not appear on the actual product.

Available Pole Counts	4, 6, 8, 10, 12, 14, 16, 18, 20, 22, 24, 26, 28, 30, 32, 36, 38, 40, 60, 64, 100, 120
-----------------------	---

Target Rotor Physical Outline - Molded (Mounting Style A)

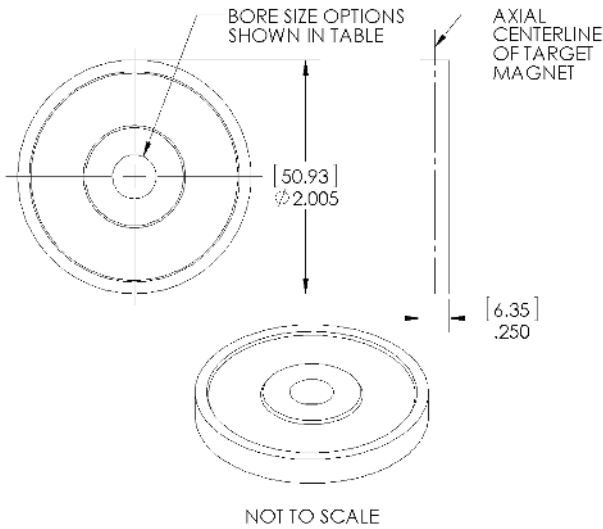

Table 2.1

Bore Size (.inch)	Motor Shaft OD Size (nominal)	NEMA Guide Shaft Tolerance	Magnet Bore MIN. (inch)	Magnet Bore MAX. (inch)
375	3/8 in (.3750")	+0.0000"/-0.0005"	.3740	.3770
394	10 mm (.3940")		.3930	.3960
473	12 mm (.4728")		.4718	.4748
500	1/2 in (.5000")		.4990	.5020
625	5/8 in (.6250")		.6240	.6270

*Other bore sizes available upon request.
Contact sales@phoenixamerica.com.*

Target Rotor Mounting Guidelines - Molded (Mounting Style A) For Slip Fit Application

- Proper alignment of the target rotor is critical for optimal performance.
- A machined step on the motor shaft provides a quick and repeatable method for positioning the target rotor. Spacers or other fixturing should be used to properly position the rotor if no mechanical locating features are on the shaft.
- Various adhesives can be used to bond the target rotor to the motor shaft. Shaft alloys, operating environment, and shaft speed and acceleration should be taken into consideration when selecting an appropriate bonding agent. Loctite threadlockers and retaining compounds have proved effective in bonding the target rotor to the motor shaft. Loctite 263 and 2760 threadlockers and Loctite 638 and 680 retaining compounds are good candidates. These materials have been effective in past experience; testing under actual operating conditions should be used to qualify any bonding material.
- For best results, the motor shaft should be clean and free of any oils, lubricants, or solvents.
- Apply adhesive around the leading edge of the shaft and inside the hole in the rotor. Use a rotating motion when assembling the magnet to the shaft to insure good adhesive coverage.
- The use of primers and activators can be used to improve bond strength and cure rate.
- For non-critical applications or for fast bonding for evaluation, a cyanoacrylate adhesive (super glue) can be used. Loctite 401 and 410 have proven effective for quick bonding applications.

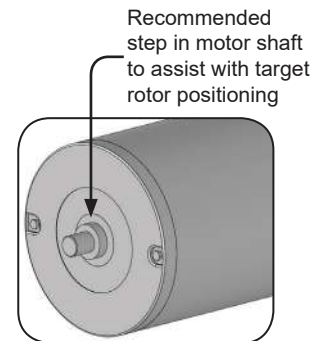
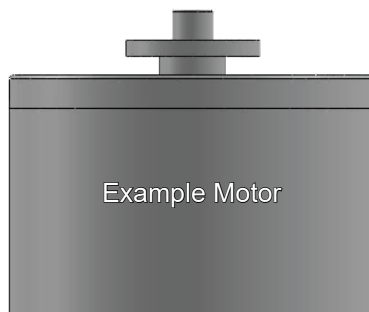

Part Number Description

Series	Design Style	Bore Size	Magnet Material	Pole Count
G32	A Molded	375 3/8 in 394 10 mm 473 12 mm 500 1/2 in 625 5/8 in	25 Magnalox 300 50 Neobond 12M 75 Neobond 30M 85 Neobond 32P	R04 4 Poles R06 6 Poles R08 8 Poles R10 10 Poles R12 12 Poles R14 14 Poles R16 16 Poles R18 18 Poles R20 20 Poles R22 22 Poles R24 24 Poles R26 26 Poles R28 28 Poles R30 30 Poles R32 32 Poles R36 36 Poles R38 38 Poles R40 40 Poles R60 60 Poles R64 64 Poles R100 100 Poles R120 120 Poles

Example: G32-A-375-25-R08