

PART NUMBER	REVISION	DESCRIPTION	FEED TYPE
2266262-1	E	FINE CRIMP HEIGHT ADJUST	MECHANICAL
2266262-2	F	FINE CRIMP HEIGHT ADJUST	PNEUMATIC
5-2266262-1	F	SEAL STRIPPER CRIMPER TERMINATING UNIT	MECHANICAL
5-2266262-2	F	SEAL STRIPPER CRIMPER TERMINATING UNIT	PNEUMATIC
7-2266262-1	E	MECHANICAL AND CRIMP TOOLING KIT	MECHANICAL
7-2266262-2	F	PNEUMATIC AND CRIMP TOOLING KIT	PNEUMATIC
7-2266262-7	A	CRIMP TOOLING KIT	-

ATLANTIC VERSION TERMINATOR INTERFACE ADAPTER

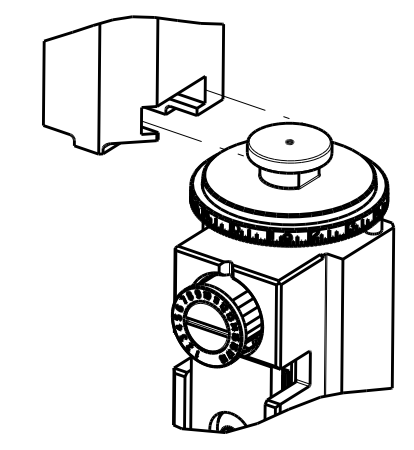

APPLICATOR DATA		
CRIMP	SIZE	TYPE
WIRE	1.60 mm [.063]	F
INSUL	3.05 mm [.120]	O

APPLICATOR INSTRUCTIONS
408-35042

TERMINAL DATA: KOSTAL TERMINAL KOSTAL CRIMP SPECIFICATION	
TERMINAL NAME: MLK 1.2 TERMINAL	
WIRE STRIP LENGTH	INSULATION DIAMETER RANGE
3.10-3.60 mm [.122-.142 IN]	Ø1.40-1.90 mm [.055-.075 IN]
TERMINAL APPLICATION SPECIFICATION	DOC00061540

TERMINALS APPLIED					SEAL INSULATION DIAMETER RANGE
TE TERMINAL	KOSTAL TERMINAL	TE SEAL	KOSTAL SEAL		
2113070-1	3 21 XX 73417 0	1949520-1	10800507250		1.2-1.7 mm
2113070-2	3 21 40 73412 0/3	3311352-1	10315669		1.2-1.7 mm
2113070-3	3 21 24 73412 0/3				
2113070-4	3 21 25 73412 0/3				
2113070-5	3 21 40 68091 0				
2113070-6	3 21 24 68091 0				
2113070-7	3 21 25 68091 0				

WIRE SIZE	CRIMP HEIGHT mm [INCH]	CRIMP HEIGHT REFERENCE SETTING
0.75mm2	0.95 +/- 0.03 [.037 +/- .001]	7.5
20AWG or 0.56mm2	0.93 +/- 0.03 [.037 +/- .001]	7.7
0.50mm2	0.90 +/- 0.03 [.035 +/- .001]	8.0

- RECOMMENDED SPARE PARTS
- REFER TO SUPPLIED INSTRUCTION SHEET FOR CLEANING, LUBRICATION AND STORAGE OF APPLICATOR.
- APPLY PART NUMBER 1-23419-5 LOCTITE TO THREADS OF ITEM 180
APPLY PART NUMBER 2-23419-6 LOCTITE TO THREADS OF ITEM 242.
- CRIMP HEIGHT REFERENCE SETTING WAS THE SETTING USED WHEN THE APPLICATOR WAS QUALIFIED AT THE FACTORY. ADJUSTMENT MAY BE NECESSARY WHEN RUNNING APPLICATOR IN THE FIELD.
- APPLY TORQ-SEAL IN ALLEN SOCKET TO FILL HOLE AFTER FLAT HD HAS BEEN ADJUSTED TO CORRECT HEIGHT AT QUALIFICATION.
APPLY #1-23419-5 LOC-TITE TO THREADS.
- UNLESS SPECIFIED OTHERWISE TORQUE VALUES SHALL BE USED PER DOCUMENT, 101-35000.

LOC	DIST	REV	LTN	DESCRIPTION	DATE	OWN	APVD
A	66	E		ECR-18-015550	30SEP2018	KH	LZ
		E1		ECR-18-016478	17OCT2018	MZ	KZ
		F		ECR-19-014336	12SEP2019	JAH	TE
		F1		ECR-19-018060	19NOV2019	FZ	RK

-	-	-	1	1	-	-	1803515-3	RAM ASSEMBLY, SF ATLANTIC	293
-	-	-	1	1	-	-	2-1803583-1	APPLICATOR BASIC ASSEMBLY, SF	292
-	1	-	1	-	1	-	2119641-1	FEED CAM, AIR FEED	248
-	1	1	1	1	1	1	2119082-8	CAM, SNAIL, INSULATION ADJUSTMENT	244
-	1	1	1	1	1	1	2079764-1	WASHER, WAVE SPRING, CREST-TO-CREST	243
3	-	1	1	1	1	1	2119083-1	RETAINER, INSULATION DIAL	242
-	1	1	1	1	1	1	7-18023-7	SCR, SKT HD CAP M3 X 4.0	241
-	-	1	-	1	-	1	2119580-1	MECHANICAL FEED ASSEMBLY	239
-	1	-	1	-	1	-	2844940-1	AIR FEED MODULE	238
-	-	-	1	1	-	-	4-1722335-3	STRIPPER, SIDE FEED	182
3	-	-	1	1	-	-	1-5018030-0	NUT, HEX, REG, RoHS, M3.5	181
-	-	-	1	1	-	-	1-1752354-6	STANDOFF, HOLD-DOWN	180
-	-	-	1	1	-	-	993111-1	PIN, SLOTTED SPRING 3.0 X 20.0	177
-	-	-	1	1	-	-	5-22280-0	SPRING, COMPRESSION	176
-	-	-	1	1	-	-	1752353-3	GUIDE PIN, HOLDDOWN	175
-	-	-	1	1	-	-	1901680-2	GUIDE PIN, HOLDDOWN	174
-	REF	REF	REF	REF	REF	REF	994970-2	COUNTER, MAGNETIC	164
-	1	1	1	1	1	1	2844908-1	SCREW, LOCKING	99
-	1	1	1	1	1	1	2844907-1	POST, LOCKING	98
-	1	1	1	1	1	1	455888-5	SPACER, CRIMPER	82
-	1	1	1	1	1	1	1803607-3	DOCUMENTATION PACKAGE	71
-	1	1	1	1	1	1	2119740-1	TAG IDENTIFICATION	67
-	2	2	2	2	2	2	2168078-1	SCREW, DRIVE, RH, RoHS, 2 x .188	66
-	1	1	1	1	1	1	2168083-2	SCR, SKT HD CAP, RoHS, M4 X 8.0	60
-	1	1	1	1	1	1	5-18022-5	SCR, HEX HD CAP, M4 X 6.0	59
5	-	1	1	1	1	1	985575-3	SCR, FLT SKT HD CAP M3 X 10.0	57
-	1	1	1	1	1	1	1338685-1	PAWL, FEED	56
-	4	4	4	4	4	4	2168083-3	SCR, SKT HD CAP, RoHS, M4 X 12.0	54
-	2	2	2	2	2	2	2168083-8	SCR, SKT HD CAP, RoHS, M4 X 16	53
-	1	1	1	1	1	1	5018030-1	NUT, HEX, REG, RoHS, M3	52
-	1	1	1	1	1	1	811242-5	BUMPER, HOLD DOWN	51
-	1	1	1	1	1	1	690753-2	SPACER, TONKER	50
-	1	2	1	2	1	2	18023-9	SCR, SKT HD CAP M4 X 6.0	49
-	-	1	-	1	-	1	2119652-1	FEED CAM, PRE FEED	48
-	-	1	-	1	-	1	2119653-1	FEED CAM, POST FEED	47
-	1	1	-	-	1	1	1803583-9	APPLICATOR BASIC ASSEMBLY, SF	46
-	1	1	-	-	1	1	1803515-1	RAM ASSEMBLY, SF ATLANTIC	44
-	1	1	1	1	1	1	1803602-1	SCR, BHSC, RoHS (M8 X 25)	41
-	1	1	1	1	1	1	2-1752356-0	SUPPORT, TERMINAL	34
-	2	2	2	2	2	2	2079383-5	SCR, BHSC, RoHS (M4 X 20)	33
-	2	2	2	2	2	2	3-2844962-0	SPACER, CYLINDRICAL, STRIP GUIDE	30
-	1	1	1	1	1	1	2844992-4	ASSEMBLY, STRIP GUIDE	29
-	1	1	1	1	1	1	455888-3	SPACER, CRIMPER	28
-	1	1	1	1	1	1	240792-1	DRAG, TERMINAL	25
-	1	1	1	1	1	1	1320928-6	STRIP GUIDE	24
-	1	1	-	-	1	1	2168083-2	SCR, SKT HD CAP, RoHS, M4 X 8.0	21
-	2	2	1	1	2	2	1-18028-2	WASHER, FLAT, REG M4	20
-	1	1	-	-	1	1	2119533-1	STRIPPER, SIDE FEED	19
1	-	1	1	1	1	1	2119806-1	INSERT, SHEAR	13
-	1	1	1	1	1	1	3-22280-3	SPRING, COMPRESSION	12
-	1	1	1	1	1	1	1-356885-4	STOP, SHEAR	11
1	-	1	1	1	1	1	2119805-1	SHEAR HOLDER, FRONT	10
1	-	1	1	1	1	1	318707-1	FLOATING SHEAR, FRONT	9
1	1	2	2	1	1	1	6-1633703-0	ANVIL, COMBINATION	8
-	1	1	1	1	1	1	240641-4	SPACER	7
-	-	-	-	-	-	-	-	-	6
-	1	1	1	1	1	1	2-2119781-0	DEPRESSOR, SHEAR	5
-	1	1	1	1	1	1	2-238011-1	BLOCK, CRIMPER SPACER	4
1	1	2	2	1	1	1	5-1633965-5	CRIMPER, INSULATION O PREMIUM	3
-	1	1	1	1	1	1	455888-9	SPACER, CRIMPER	2
1	1	2	2	1	1	1	8-1633588-1	CRIMPER, WIRE	1

***WARNING**
 ON INSTALLATION, SET WIRE DISC TO CRIMP HEIGHT REFERENCE SETTING FOR LARGEST WIRE SIZE. CRIMP HEIGHT REFERENCE SETTINGS GREATER THAN THE VALUE SHOWN MAY CAUSE DAMAGE TO THE CRIMP TOOLING. REFER TO THE INSTRUCTION SHEET FOR PROPER SETUP AND ADJUSTMENTS.

ATLANTIC VERSION
 Shown on sheets 1 of 4 & 2 of 4
 (Pacific version shown on sheets 3 of 4 & 4 of 4)

DIMENSIONS:		TOLERANCES UNLESS OTHERWISE SPECIFIED:		MATERIAL:		FINISH:	
mm	0 PLC ±	1 PLC ±	2 PLC ±	3 PLC ±	4 PLC ±	ANGLES ±	FINISH ±

OWN	CH HUANG	10APR2014
CHK	L ZHANG	10APR2014
APVD	J GUO	10APR2014
PRODUCT SPEC		
APPLICATION SPEC		
SIZE	CAGE CODE	DRAWING NO
A1	00779	2266262
Customer Accessible Production Drawing		SCALE 1:2 SHEET 1 OF 4 REV F1

LOC	DIST	REVISIONS					
A	66	P	LTN	DESCRIPTION	DATE	DWN	APVD
		-		SEE SHEET 1	-	-	-

FEED TYPE MECHANICAL

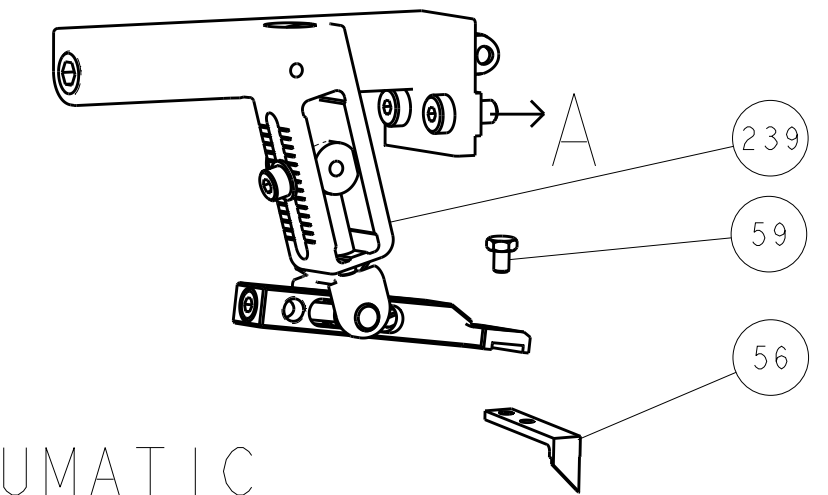

PNEUMATIC

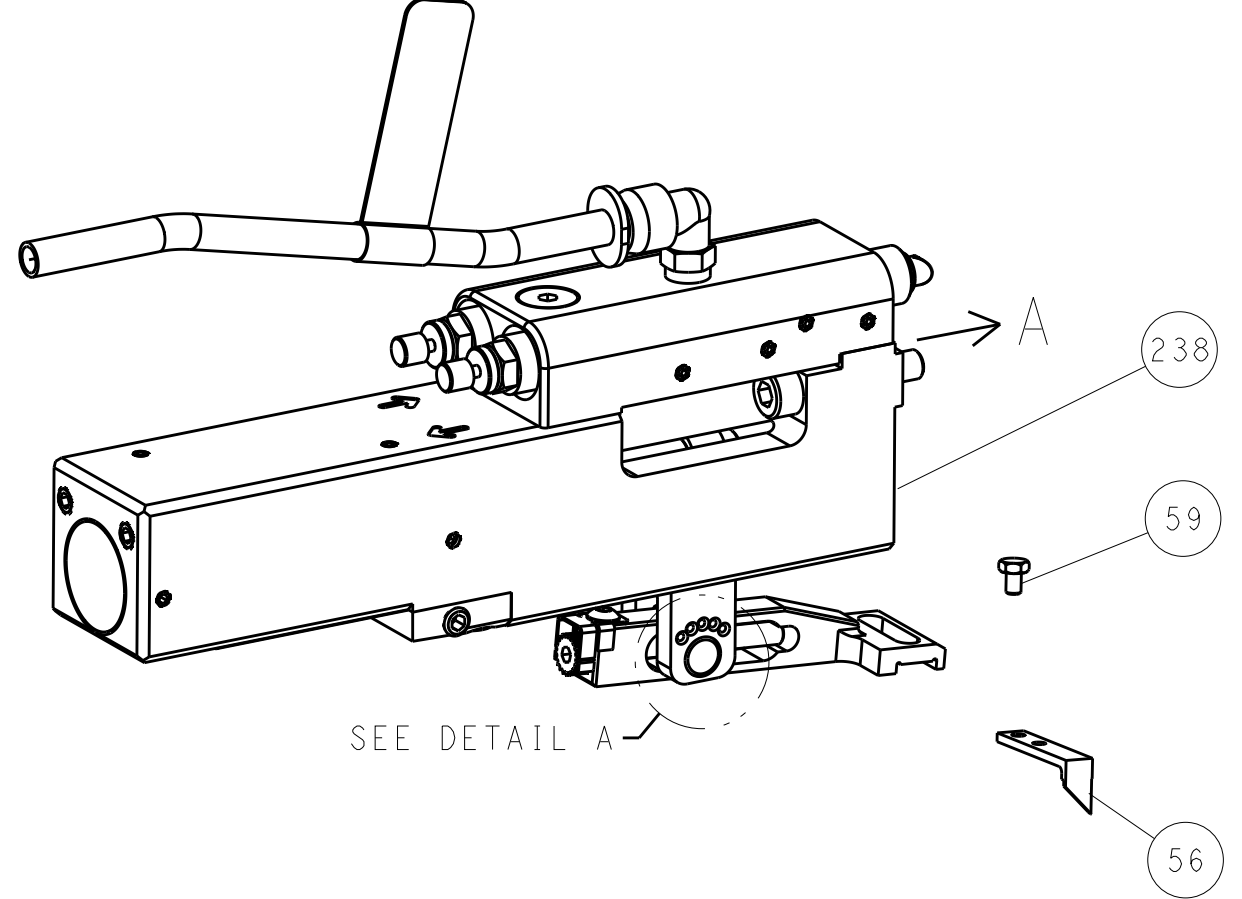

FEED SPRING SETTING POSITION (SHOWN FROM REAR SIDE)

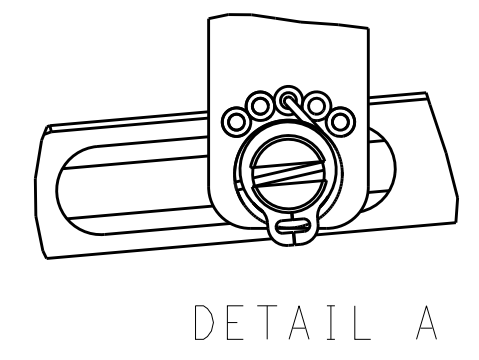

DETAIL A

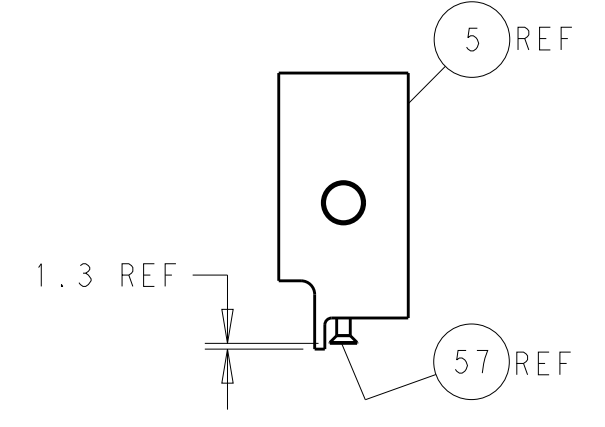
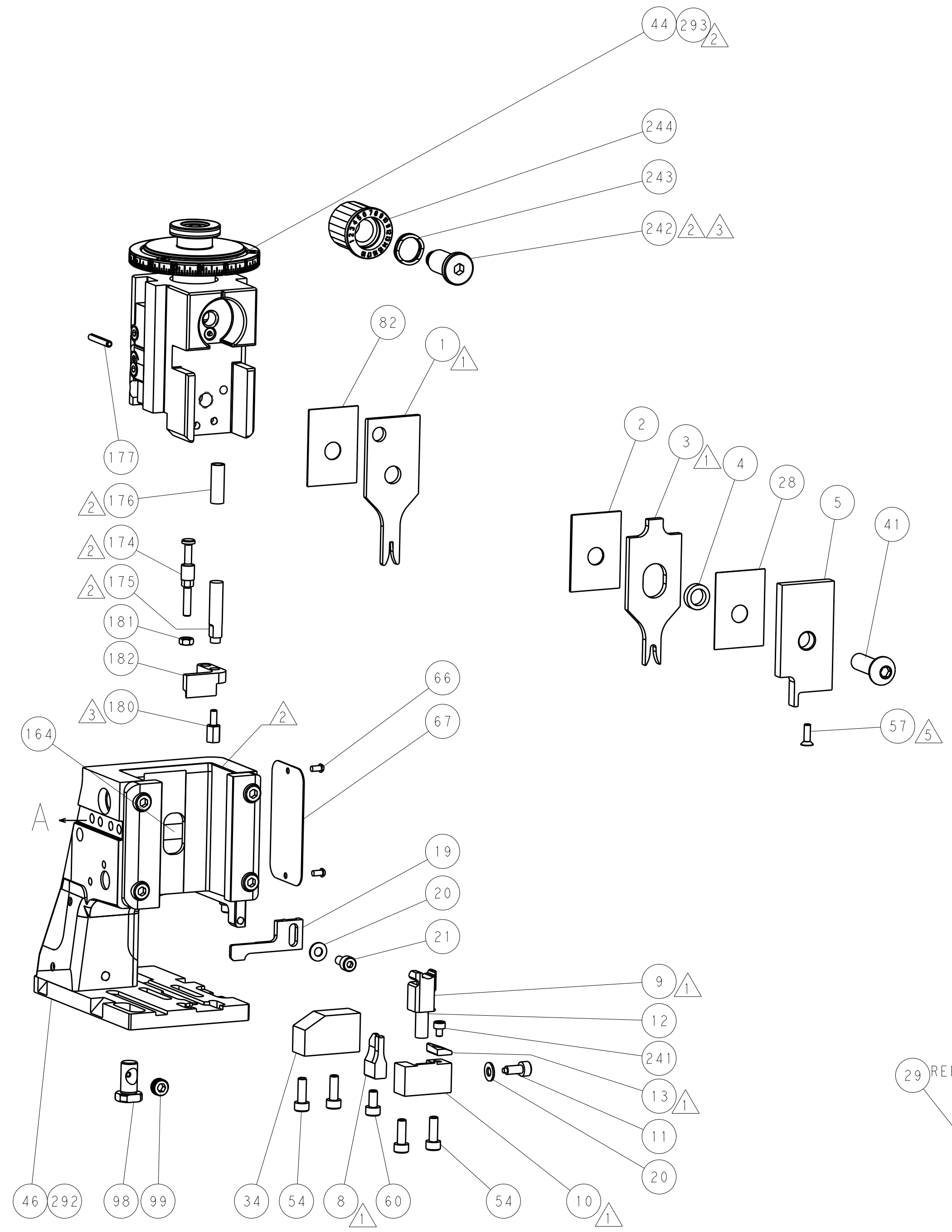
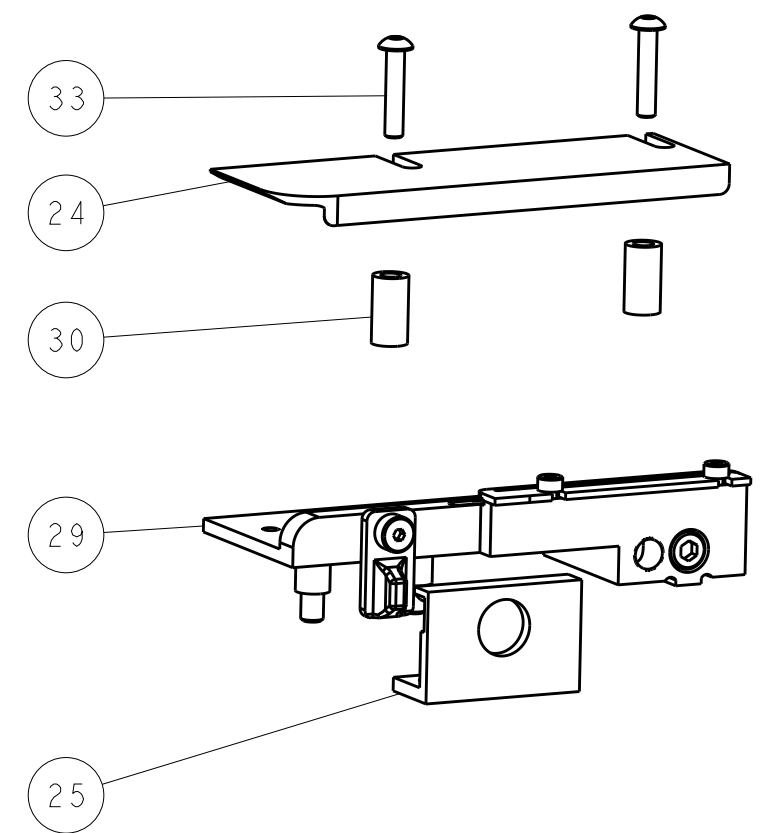
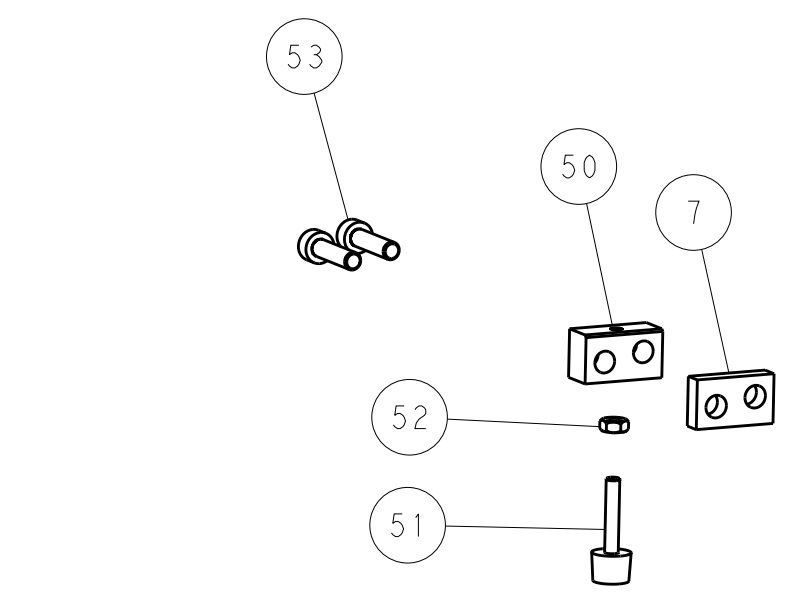

SHEAR DEPRESSOR DETAIL

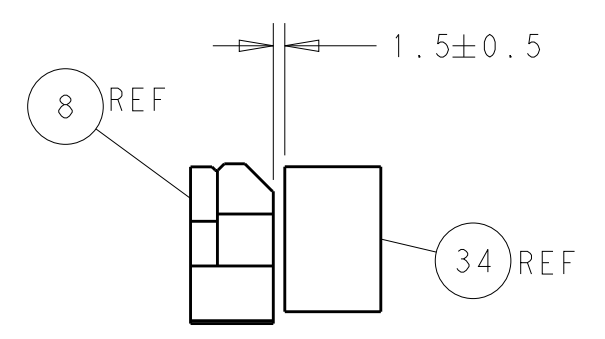

TERMINAL SUPPORT LOCATION

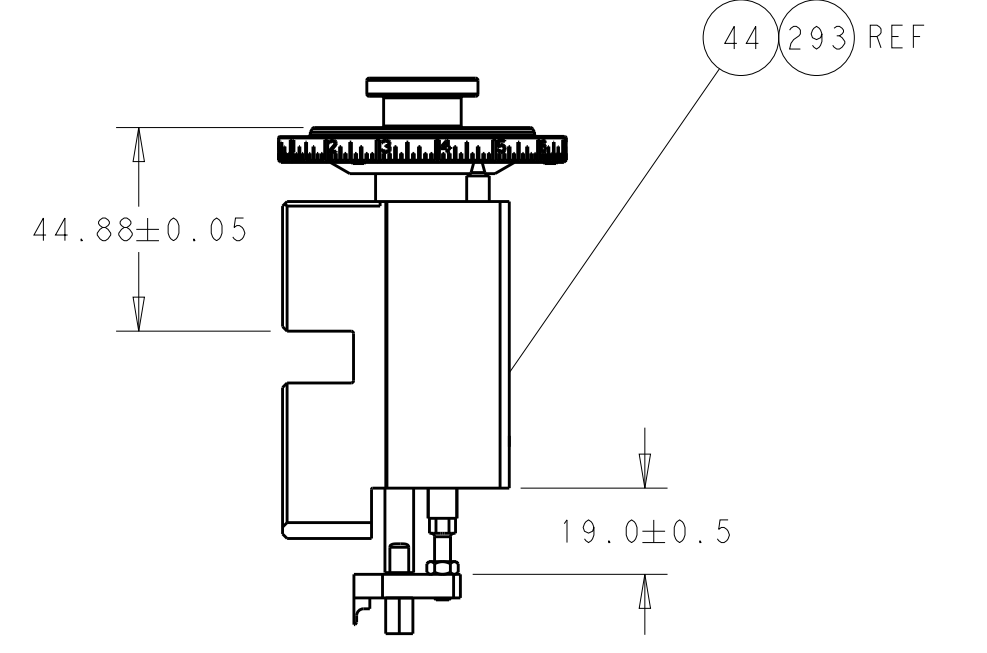

RAM AND HOLD DOWN SET-UP

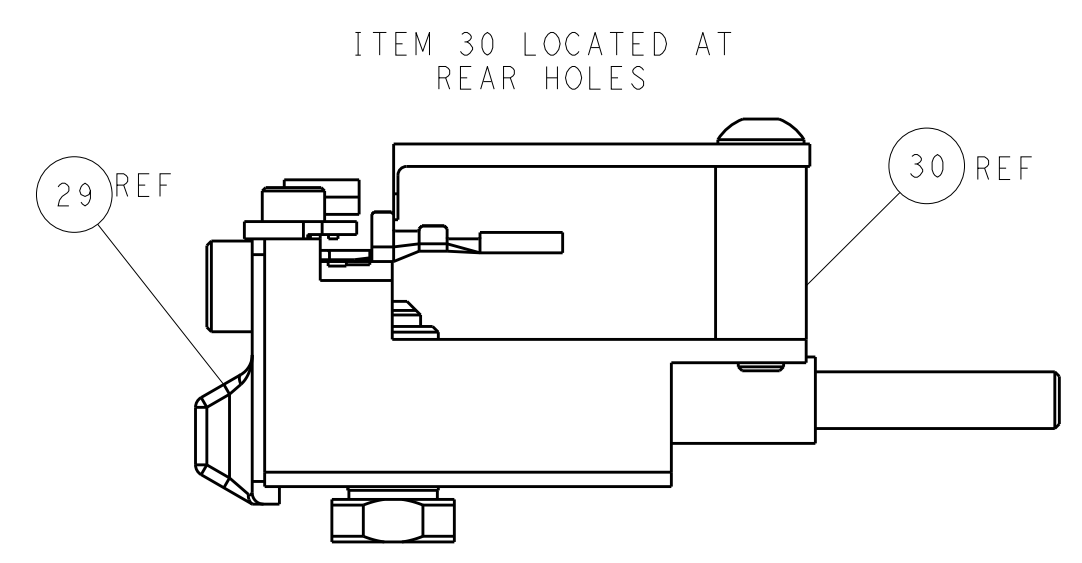

ITEM 30 LOCATED AT REAR HOLES

CAM POSITIONS

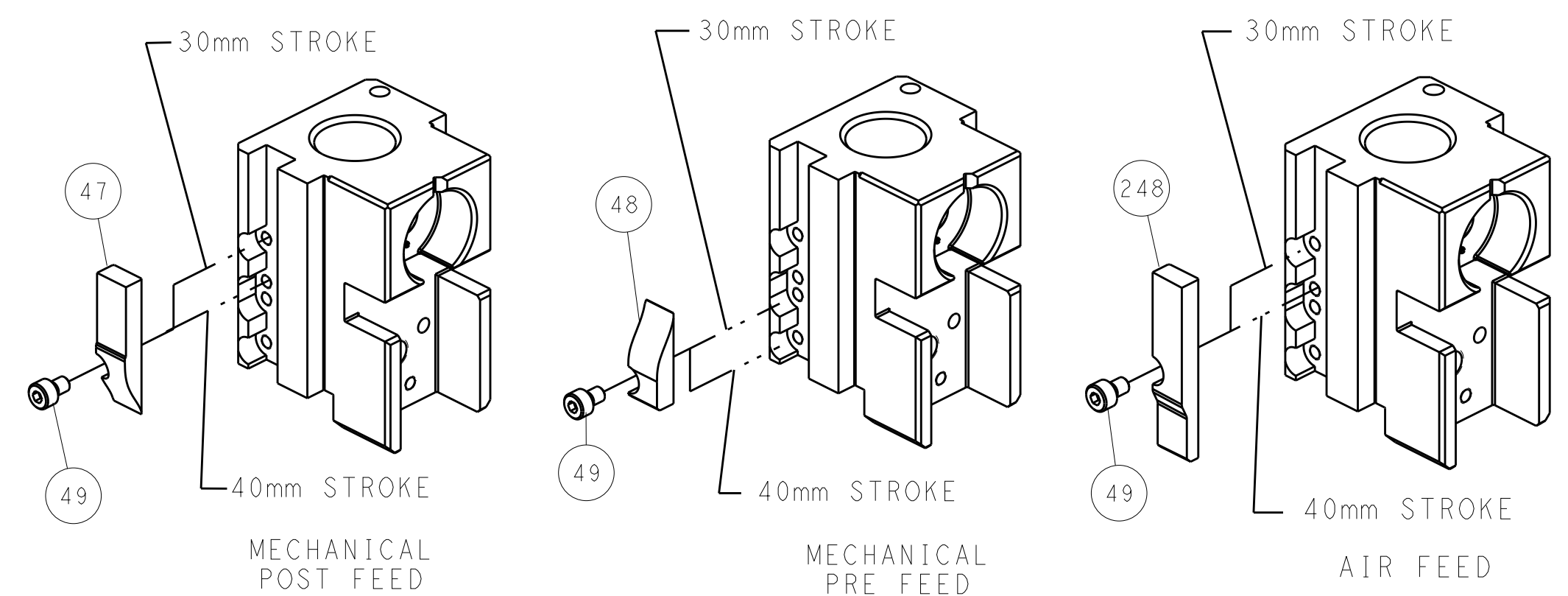

ATLANTIC VERSION
 Shown on sheets 1 of 4 & 2 of 4
 (Pacific version shown on sheets 3 of 4 & 4 of 4)

DIMENSIONS:		TOLERANCES UNLESS OTHERWISE SPECIFIED:		DWN: H. HUANG 10APR2014		TE Connectivity	
mm	0 PLC ±	1 PLC ±	2 PLC ±	3 PLC ±	4 PLC ±	Harrisburg, PA 17105-3608	
MATERIAL:		FINISH:		CHK: L. ZHANG 10APR2014		NAME: Ocean Side Feed Applicator	
				APVD: H. GUO 10APR2014		SIZE: CAGE CODE: DRAWING NO: A1 00779 ©=2266262	
				PRODUCT SPEC:		RESTRICTED TO:	
				APPLICATION SPEC:		Customer Accessible Production Drawing	
				WEIGHT:		SCALE: 1:2 SHEET 2 OF 4 REV F1	

PART NUMBER	REVISION	DESCRIPTION	FEED TYPE
2-2266262-1	E	FINE CRIMP HEIGHT ADJUST	MECHANICAL
2-2266262-2	F	FINE CRIMP HEIGHT ADJUST	PNEUMATIC
7-2266262-7	A	CRIMP TOOLING KIT	-

PACIFIC VERSION TERMINATOR
 INTERFACE ADAPTER

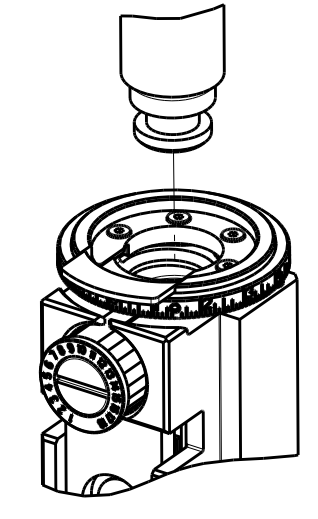

APPLICATOR DATA		
CRIMP	SIZE	TYPE
WIRE	1.60 mm [.063]	F
INSUL	3.05 mm [.120]	O

APPLICATOR INSTRUCTIONS
 408-35042

TERMINAL DATA: KOSTAL TERMINAL KOSTAL CRIMP SPECIFICATION				
TERMINAL NAME: MLK 1.2 TERMINAL				
WIRE STRIP LENGTH	INSULATION DIAMETER RANGE			
3.10-3.60 mm [.122-.142 IN]	∅1.40-1.90 mm [.055-.075 IN]			
TERMINAL APPLICATION SPECIFICATION	DOC00061540			
TERMINALS APPLIED				
TE TERMINAL	KOSTAL TERMINAL	TE SEAL	KOSTAL SEAL	SEAL INSULATION DIAMETER RANGE
2113070-1	3 21 XX 73417 0	1949520-1	10800507250	1.2-1.7 mm
2113070-2	3 21 40 73412 0/3	3311352-1	10315669	1.2-1.7 mm
2113070-3	3 21 24 73412 0/3			
2113070-4	3 21 25 73412 0/3			
2113070-5	3 21 40 68091 0			
2113070-6	3 21 24 68091 0			
2113070-7	3 21 25 68091 0			

WIRE SIZE	CRIMP HEIGHT mm [INCH]	CRIMP HEIGHT REFERENCE SETTING
0.75mm ²	0.95 +/- 0.03 [.037 +/- .001]	7.5
20AWG or 0.56mm ²	0.93 +/- 0.03 [.037 +/- .001]	7.7
0.50mm ²	0.90 +/- 0.03 [.035 +/- .001]	8.0

- 1 RECOMMENDED SPARE PARTS
- 2 REFER TO SUPPLIED INSTRUCTION SHEET FOR CLEANING, LUBRICATION AND STORAGE OF APPLICATOR.
- 3 APPLY PART NUMBER 2-23419-6 LOCTITE TO THREADS OF ITEM 242.
- 4 CRIMP HEIGHT REFERENCE SETTING WAS THE SETTING USED WHEN THE APPLICATOR WAS QUALIFIED AT THE FACTORY. ADJUSTMENT MAY BE NECESSARY WHEN RUNNING APPLICATOR IN THE FIELD.
- 5 APPLY TORQ-SEAL IN ALLEN SOCKET TO FILL HOLE AFTER FLAT HD HAS BEEN ADJUSTED TO CORRECT HEIGHT AT QUALIFICATION. APPLY #1-23419-5 LOC-TITE TO THREADS.
6. UNLESS SPECIFIED OTHERWISE TORQUE VALUES SHALL BE USED PER DOCUMENT, 101-35000.

***WARNING**
 ON INSTALLATION, SET WIRE DISC TO CRIMP HEIGHT REFERENCE SETTING FOR LARGEST WIRE SIZE. CRIMP HEIGHT REFERENCE SETTINGS GREATER THAN THE VALUE SHOWN MAY CAUSE DAMAGE TO THE CRIMP TOOLING. REFER TO THE INSTRUCTION SHEET FOR PROPER SETUP AND ADJUSTMENTS.

LOC	DIST	REVISIONS					
		P	LTN	DESCRIPTION	DATE	OWN	APVD
A	66	-	-	SEE SHEET 1	-	-	-

-	1	1	2119082-8	CAM, SNAIL, INSULATION ADJUSTMENT	244
-	1	1	2079764-1	WASHER, WAVE SPRING, CREST-TO-CREST	243
-	1	1	2119083-1	RETAINER, INSULATION DIAL	242
-	1	1	7-18023-7	SCR, SKT HD CAP M3 X 4.0	241
-	-	1	2119580-1	MECHANICAL FEED ASSEMBLY	239
-	1	-	2844940-1	AIR FEED MODULE	238
-	REF	REF	994970-2	COUNTER, MAGNETIC	164
-	1	-	2119641-2	FEED CAM, AIR FEED	151
-	1	1	2168083-8	SCR, SKT HD CAP, RoHS, M4 X 16	144
-	4	4	2168083-9	SCR, SKT HD CAP, RoHS, M4 X 20	143
-	-	1	2119653-2	FEED CAM, POST FEED	142
-	1	1	1-1803583-0	APPLICATOR BASIC ASSEMBLY, SF	141
-	1	1	1803516-1	RAM ASSEMBLY, SF PACIFIC	140
-	1	1	2844908-1	SCREW, LOCKING	99
-	1	1	2844907-1	POST, LOCKING	98
-	1	1	455888-5	SPACER, CRIMPER	82
-	1	1	1803607-3	DOCUMENTATION PACKAGE	71
-	1	1	2119740-1	TAG, IDENTIFICATION	67
-	2	2	2168078-1	SCREW, DRIVE, RH, RoHS, 2 x .188	66
-	1	1	5-18022-5	SCR, HEX HD CAP, M4 X 6.0	59
-	1	1	985575-3	SCR, FLT SKT HD CAP M3 X 10.0	57
-	1	1	1338685-1	PAWL, FEED	56
-	2	2	2168083-8	SCR, SKT HD CAP, RoHS, M4 X 16	53
-	1	1	5018030-1	NUT, HEX, REG, RoHS, M3	52
-	1	1	811242-5	BUMPER, HOLD DOWN	51
-	1	1	690753-2	SPACER, TONKER	50
-	1	2	18023-9	SCR, SKT HD CAP M4 X 6.0	49
-	-	1	2119652-1	FEED CAM, PRE FEED	48
-	1	1	1803602-1	SCR, BHSC, RoHS (M8 X 25)	41
-	1	1	2-1752356-0	SUPPORT, TERMINAL	34
-	2	2	2079383-5	SCR, BHSC, RoHS (M4 X 20)	33
-	2	2	3-2844962-0	SPACER, CYLINDRICAL, STRIP GUIDE	30
-	1	1	2844992-4	ASSEMBLY, STRIP GUIDE	29
-	1	1	455888-3	SPACER, CRIMPER	28
-	1	1	240792-1	DRAG, TERMINAL	25
-	1	1	1320928-6	STRIP GUIDE	24
-	1	1	2168083-2	SCR, SKT HD CAP, RoHS, M4 X 8.0	21
-	2	2	1-18028-2	WASHER, FLAT, REG M4	20
-	1	1	2119533-1	STRIPPER, SIDE FEED	19
-	1	1	2119806-1	INSERT, SHEAR	13
-	1	1	3-22280-3	SPRING, COMPRESSION	12
-	1	1	1-356885-4	STOP, SHEAR	11
-	1	1	2119805-1	SHEAR HOLDER, FRONT	10
-	1	1	318707-1	FLOATING SHEAR, FRONT	9
-	1	1	6-1633703-0	ANVIL, COMBINATION	8
-	1	1	240641-4	SPACER	7
-	-	-	-	-	6
-	1	1	2-2119781-0	DEPRESSOR, SHEAR	5
-	1	1	2-238011-1	BLOCK, CRIMPER SPACER	4
-	1	1	5-1633965-5	CRIMPER, INSULATION O PREMIUM	3
-	1	1	455888-9	SPACER, CRIMPER	2
-	1	1	8-1633588-1	CRIMPER, WIRE	1

DIMENSIONS:		TOLERANCES UNLESS OTHERWISE SPECIFIED:		MATERIAL:		FINISH:	
mm	0 PLC ±	1 PLC ±	2 PLC ±	3 PLC ±	4 PLC ±	ANGLES ±	FINISH ±

OWN	CHK	APVD	DATE	NAME	SIZE	CAGE CODE	DRAWING NO	RESTRICTED TO
CH. HUANG	L. ZHANG	H. GUO	10APR2014	TE Connectivity Harrisburg, PA 17105-3608	A1	00779	2266262	-

Customer Accessible Production Drawing SCALE 1:2 SHEET 3 OF 4 REV F1

PACIFIC VERSION
 Shown on sheets 3 of 4 & 4 of 4
 (Atlantic version shown on sheets 1 of 4 & 2 of 4)

LOC	DIST	REVISIONS					
A	66	P	LTN	DESCRIPTION	DATE	DWN	APVD
		-	-	SEE SHEET 1	-	-	-

FEED TYPE MECHANICAL

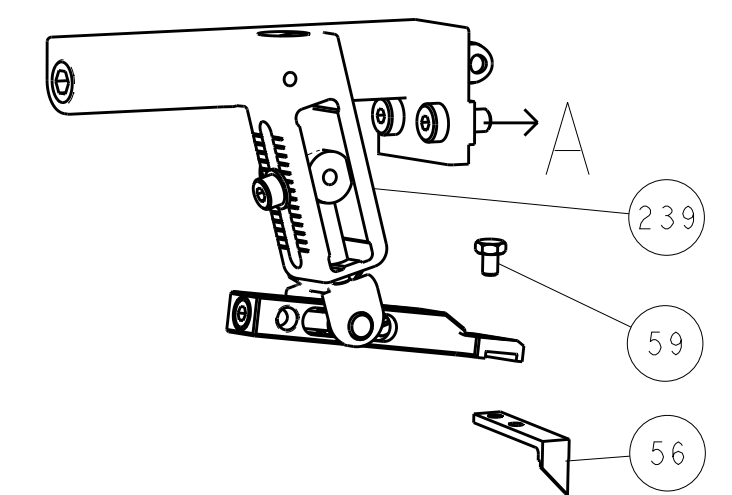

PNEUMATIC

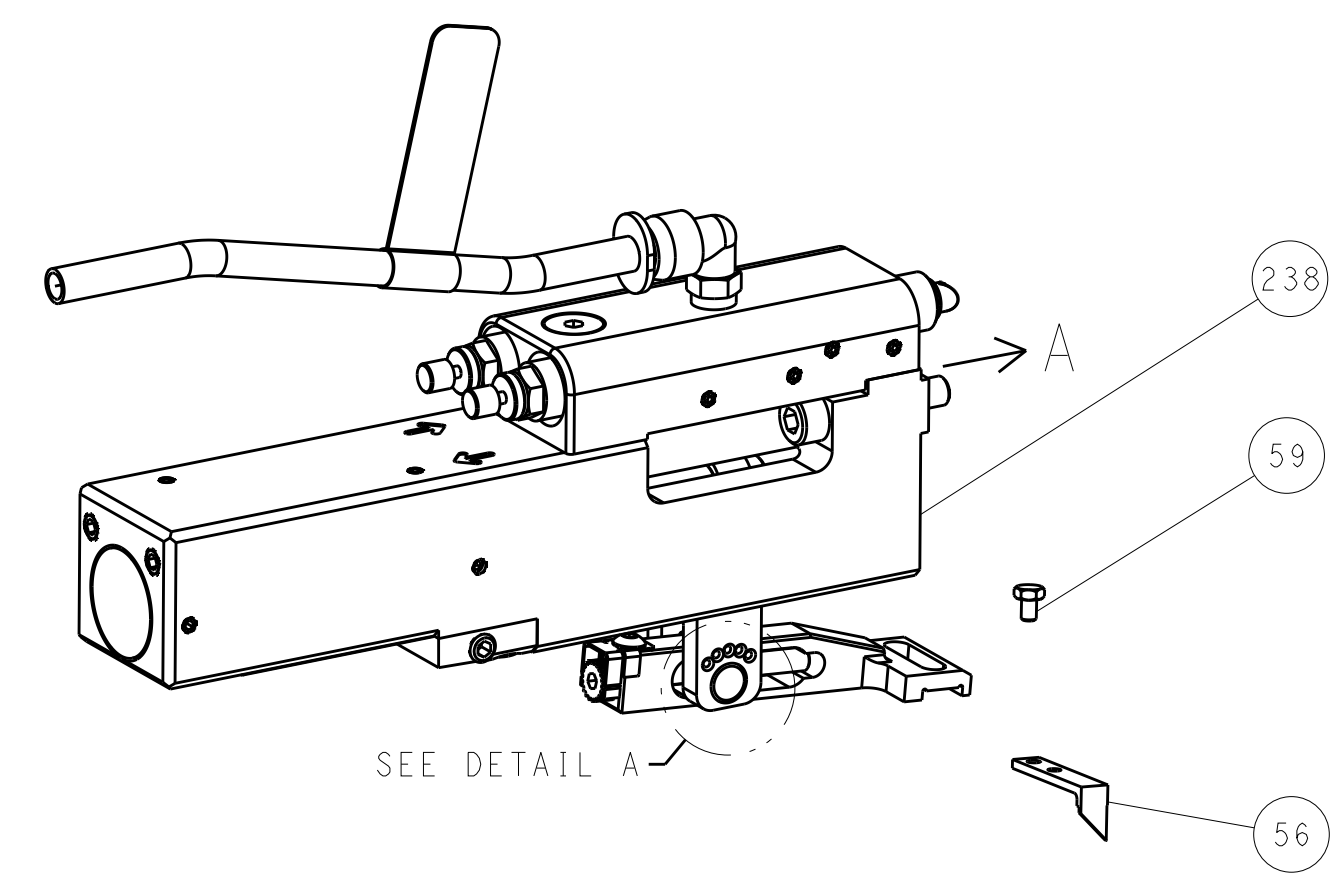

FEED SPRING SETTING POSITION (SHOWN FROM REAR SIDE)

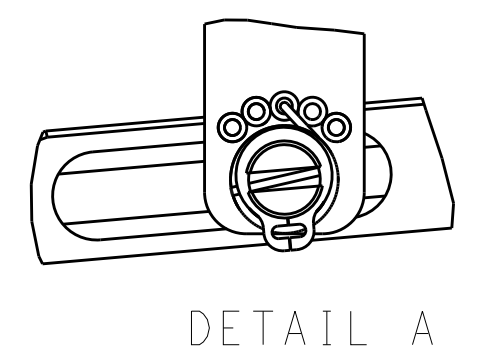

CAM POSITIONS

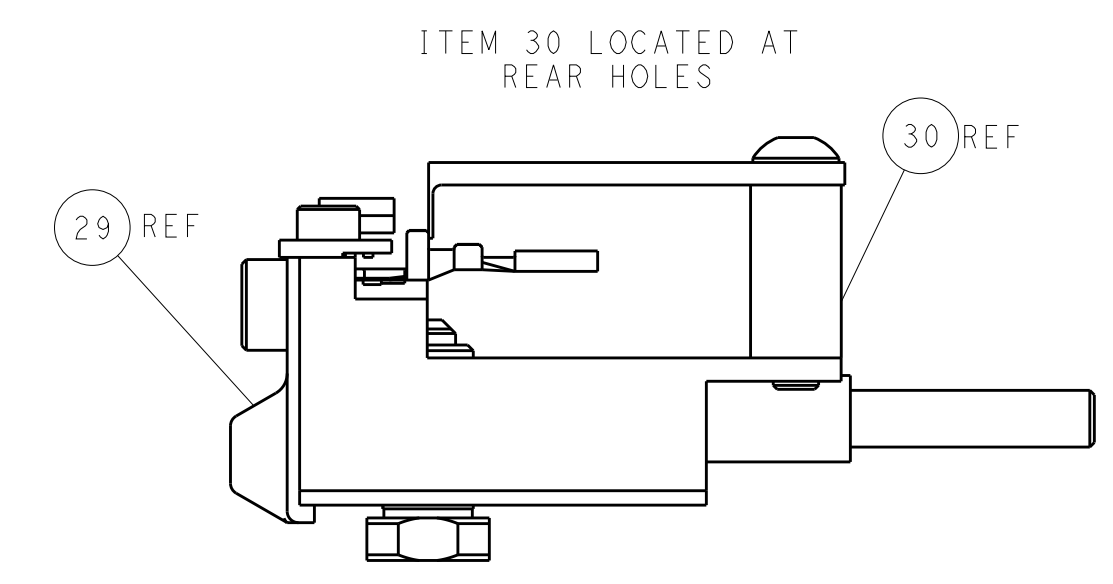
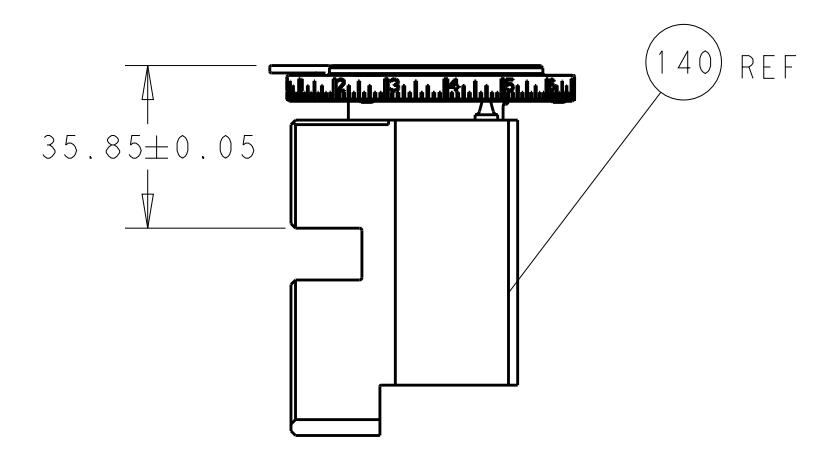
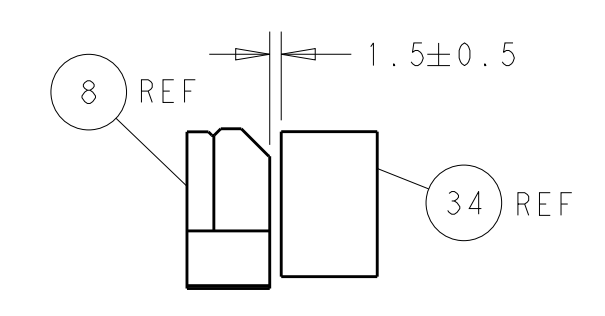
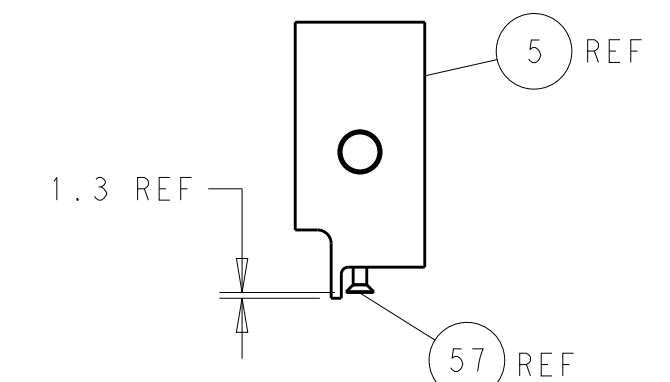
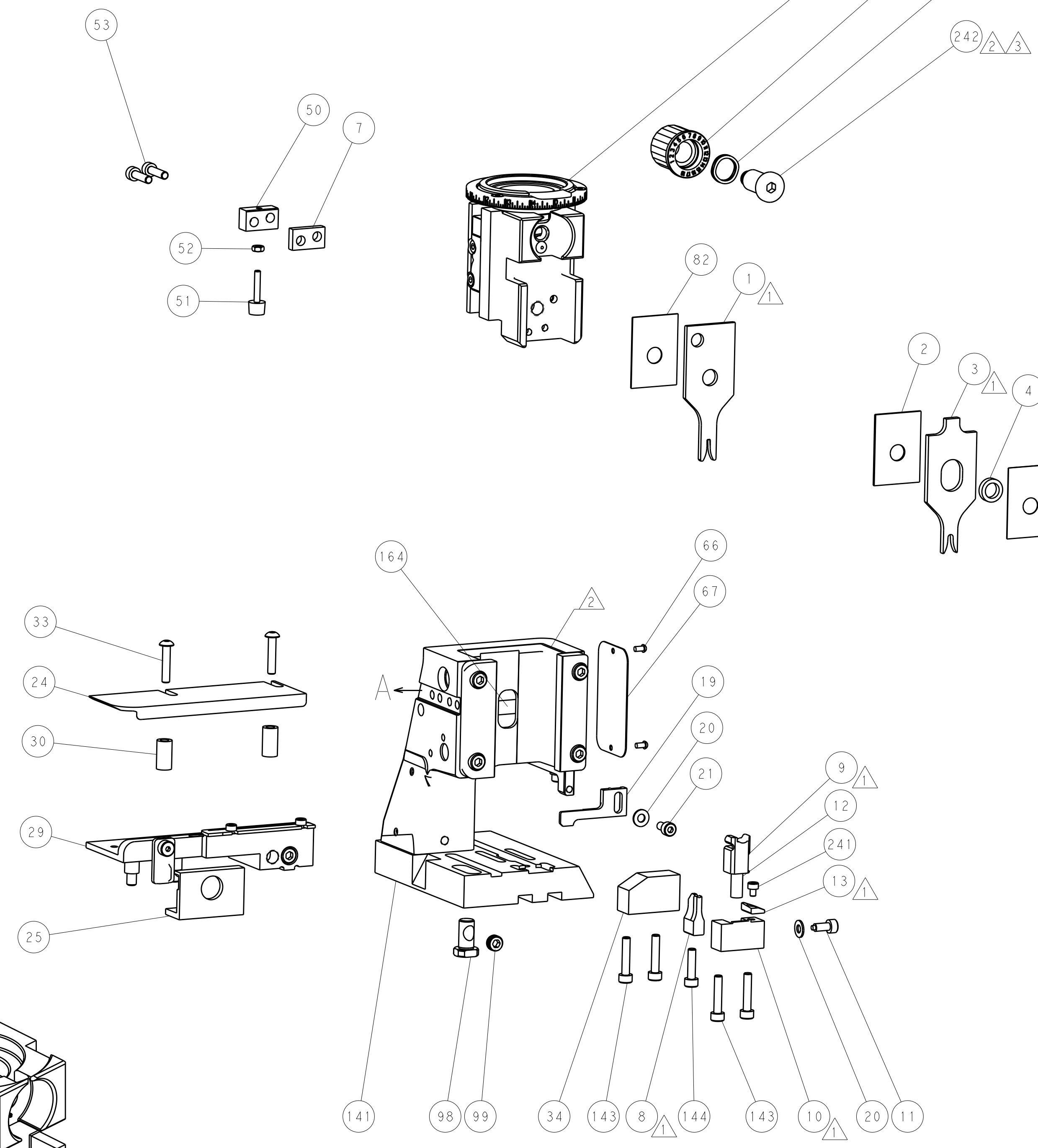
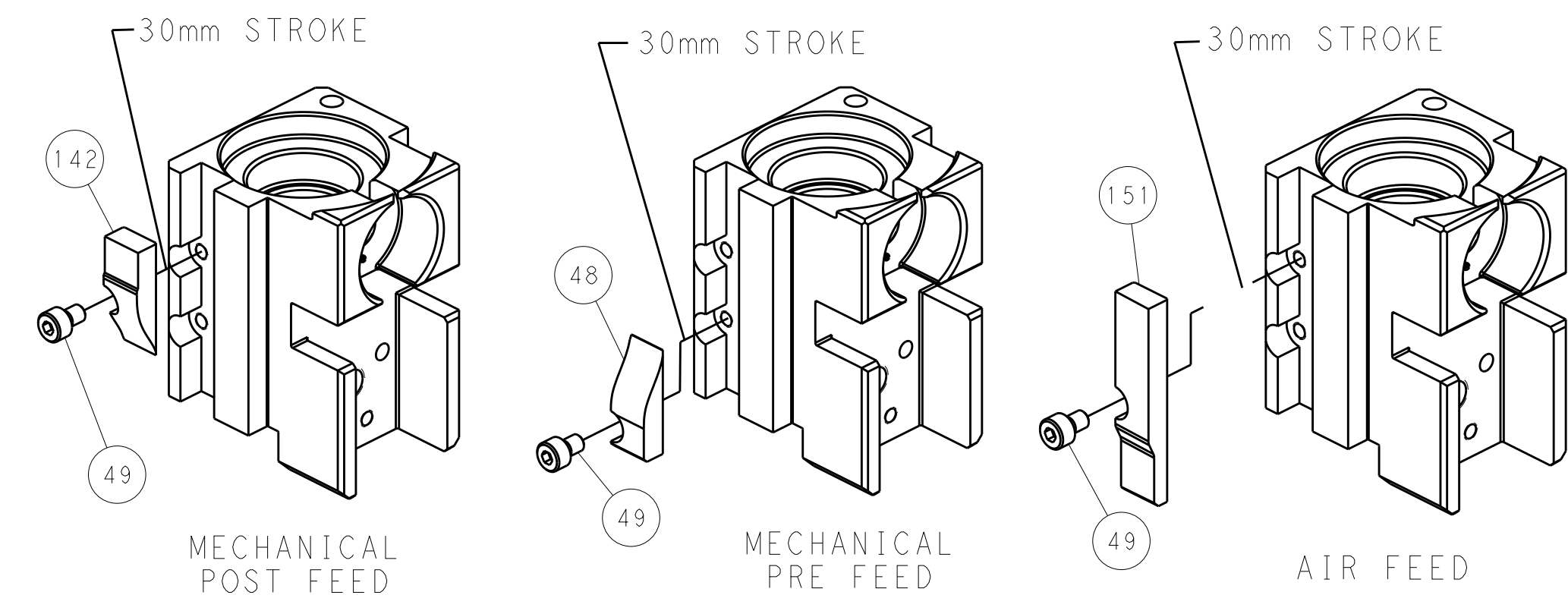

PACIFIC VERSION
 Shown on sheets 3 of 4 & 4 of 4
 (Atlantic version shown on sheets 1 of 4 & 2 of 4)

<small>THE INFORMATION CONTAINED HEREIN IS UNCLASSIFIED EXCEPT WHERE SHOWN OTHERWISE. IT IS THE PROPERTY OF TYCO ELECTRONICS CORPORATION AND IS TO BE CONTAINED AND CONTROLLED BY THE USER'S ORGANIZATION UNLESS BY CONTRACT FOR THE LATEST REVISION.</small>		DWN: H. HUANG 10APR2014 CHK: L. ZHANG 10APR2014 APVD: H. GUO 10APR2014	NAME: TE Connectivity Harrisburg, PA 17105-3608
DIMENSIONS: mm TOLERANCES UNLESS OTHERWISE SPECIFIED: 0 PLC ± 1 PLC ± 2 PLC ± 3 PLC ± 4 PLC ± ANGLES ±	PRODUCT SPEC APPLICATION SPEC WEIGHT MATERIAL	SIZE: A1 CAGE CODE: 00779 DRAWING NO: 2266262 SCALE: 1:2 SHEET: 4 of 4 REV: F1	RESTRICTED TO: