

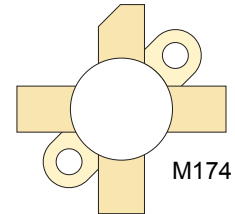

RF POWER VERTICAL MOSFET

The VRF161 is a gold-metallized silicon n-channel RF power transistor designed for broadband commercial and military applications requiring high power and gain without compromising reliability, ruggedness, or inter-modulation distortion.



FEATURES

- Improved Ruggedness $V_{(BR)DSS} = 170V$
- 200W with 24dB Typical Gain @ 30MHz, 50V
- 200W with 14dB Typical Gain @ 150MHz, 50V
- Excellent Stability & Low IMD
- Available in Matched Pairs
- 70:1 Load VSWR Capability at Specified Operating Conditions
- Nitride Passivated
- Refractory Gold Metallization
- High Power Replacement for MRF151
- RoHS Compliant 

Maximum Ratings

All Ratings: $T_c = 25^\circ C$ unless otherwise specified

Symbol	Parameter	VRF161(MP)	Unit
V_{DSS}	Drain-Source Voltage	170	V
I_D	Continuous Drain Current @ $T_c = 25^\circ C$	20	A
V_{GS}	Gate-Source Voltage	± 40	V
P_D	Total Device dissipation @ $T_c = 25^\circ C$	350	W
T_{STG}	Storage Temperature Range	-65 to 150	$^\circ C$
T_J	Operating Junction Temperature	200	

Static Electrical Characteristics

Symbol	Parameter	Min	Typ	Max	Unit
$V_{(BR)DSS}$	Drain-Source Breakdown Voltage ($V_{GS} = 0V, I_D = 100mA$)	170	180		V
$V_{DS(ON)}$	On State Drain Voltage ($I_{D(ON)} = 10A, V_{GS} = 10V$)		2.0	2.3	
I_{DSS}	Zero Gate Voltage Drain Current ($V_{DS} = 100V, V_{GS} = 0V$)			1	mA
I_{GSS}	Gate-Source Leakage Current ($V_{DS} = \pm 20V, V_{GS} = 0V$)			1.0	μA
g_{fs}	Forward Transconductance ($V_{DS} = 10V, I_D = 5A$)	6.0	8.1		mhos
$V_{GS(TH)}$	Gate Threshold Voltage ($V_{DS} = 10V, I_D = 100mA$)	2.9	3.6	4.4	V

Thermal Characteristics

Symbol	Characteristic	Min	Typ	Max	Unit
$R_{\theta JC}$	Junction to Case Thermal Resistance			0.50	$^\circ C/W$

 **CAUTION:** These Devices are Sensitive to Electrostatic Discharge. Proper Handling Procedures Should Be Followed.

Dynamic Characteristics

VRF161(MP)

Symbol	Parameter	Test Conditions	Min	Typ	Max	Unit
C_{iss}	Input Capacitance	$V_{GS} = 0V$		500		pF
C_{oss}	Output Capacitance	$V_{DS} = 150V$		180		
C_{rss}	Reverse Transfer Capacitance	$f = 1MHz$		20		

Functional Characteristics

Symbol	Parameter	Min	Typ	Max	Unit
G_{PS}	$f_1 = 30MHz, V_{DD} = 50V, I_{DQ} = 250mA, P_{out} = 200W$	20	24		dB
G_{PS}	$f = 150MHz, V_{DD} = 50V, I_{DQ} = 250mA, P_{out} = 200W$		14		
η_D	$f_1 = 30MHz, V_{DD} = 50V, I_{DQ} = 250mA, P_{out} = 200W$		50		%
IMD _(d3)	$f_1 = 30MHz, f_2 = 30.001MHz, V_{DD} = 50V, I_{DQ} = 250mA, P_{out} = 200W_{PEP}^1$		-30		dBc
ψ	$f = 30MHz, V_{DD} = 50V, I_{DQ} = 250mA, P_{out} = 200W$ CW 70:1 VSWR - All Phase Angles, 0.2mSec X 20% Duty Factor	No Degradation in Output Power			

1. To MIL-STD-1311 Version A, test method 2204B, Two Tone, Reference Each Tone

Microsemi reserves the right to change, without notice, the specifications and information contained herein.

Typical Performance Curves

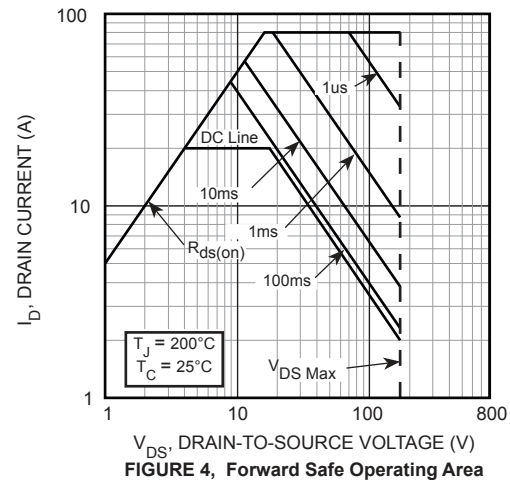
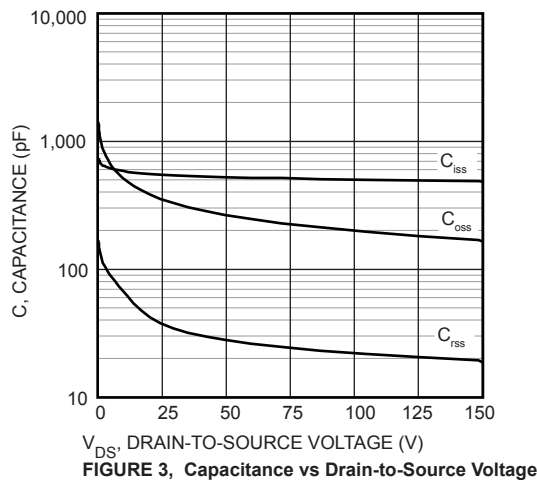
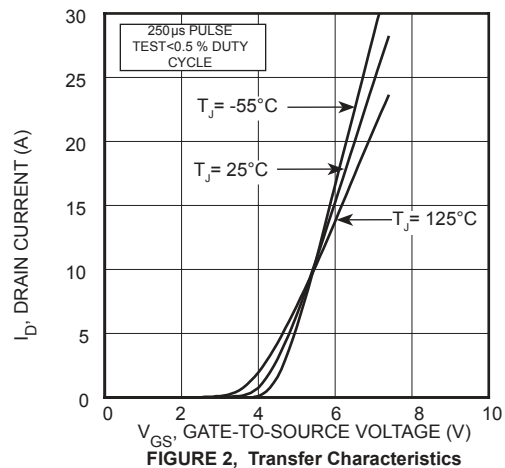
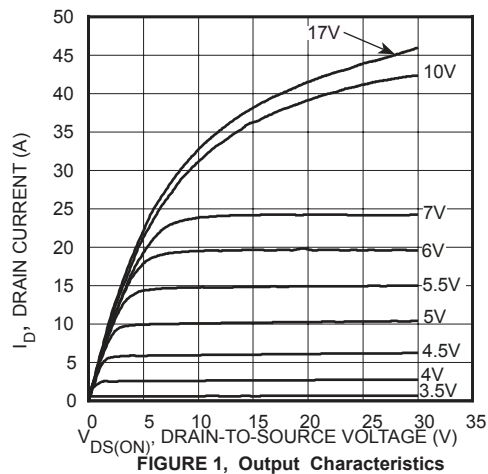

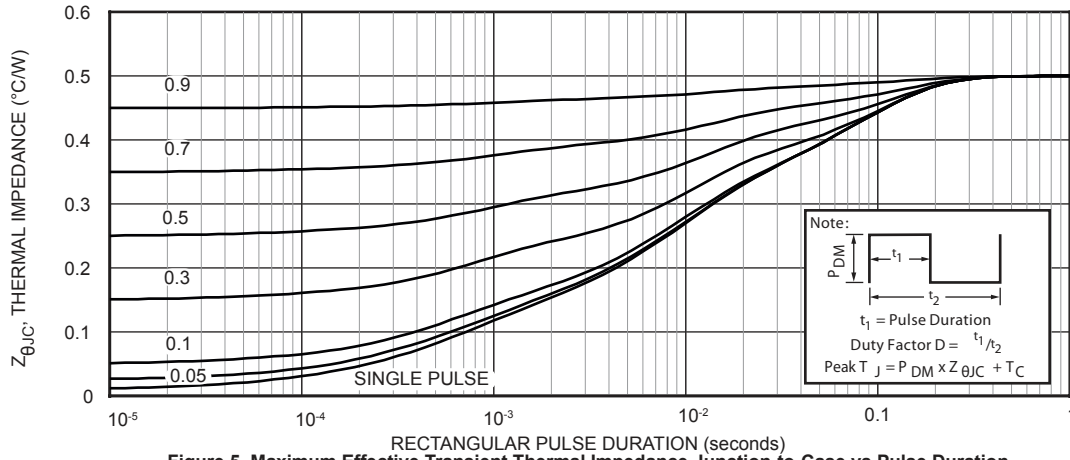

Figure 5. Maximum Effective Transient Thermal Impedance Junction-to-Case vs Pulse Duration

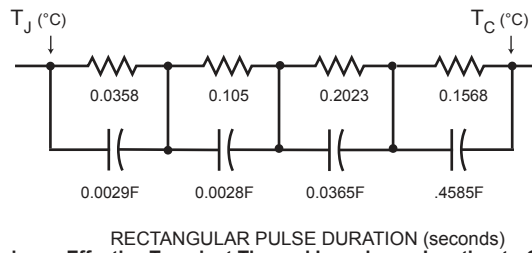

Figure 5a. Maximum Effective Transient Thermal Impedance Junction-to-Case vs Pulse Duration

Table 1. Typical Class AB Large Signal Impedances

freq	Zin*	Zout*
2.00MHz	24- j4.01	6.15-j0.13
13.56MHz	11.3- j10.6	6.11-j0.9
30MHz	5.36- j6.7	5.68-j1.81
100MHz	3.5- j2.91	2.35-j4.12
150MHz	3.45- j1.83	1.81-j2.99

Zin - gate shunted with 25 ohms Idq = .25A Zol = conj of opt load for 200w out at Vdd = 50V

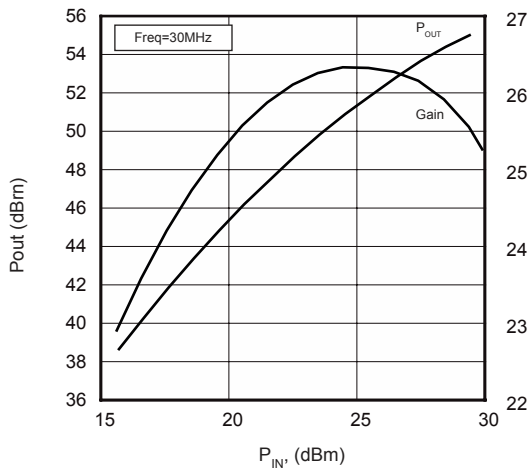

Figure 6. P_{OUT} and Gain vs P_{IN}

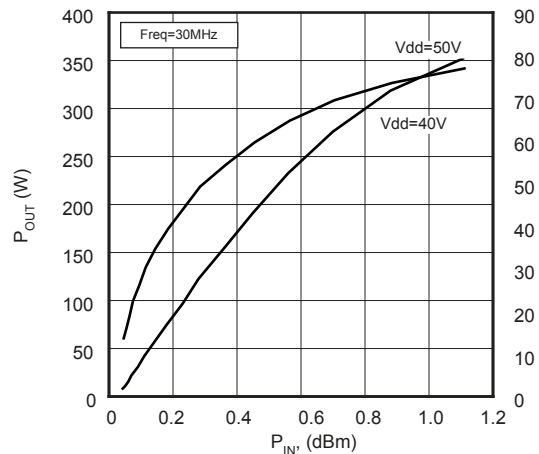
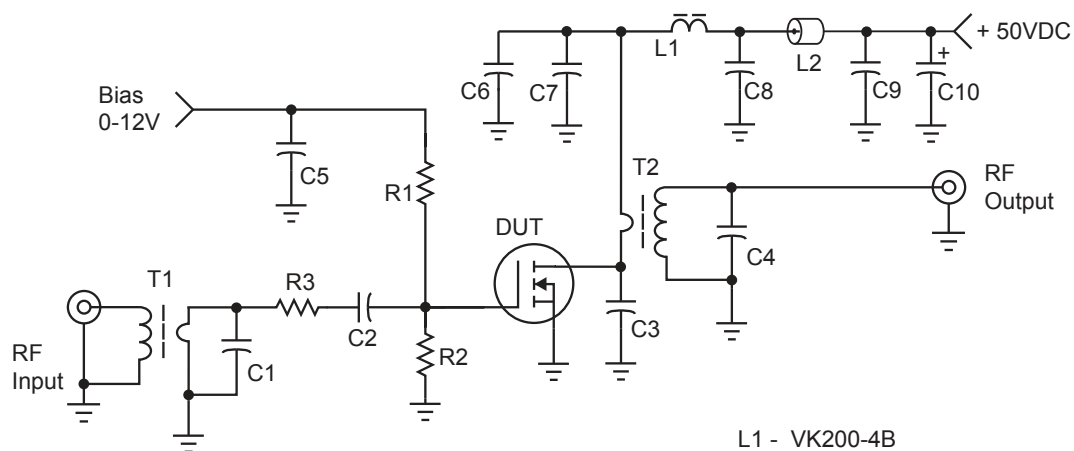

Figure 7. Eff and P_{OUT} vs. P_{IN}

30 MHz test Circuit



C1 -- 470 pF ATC 700B
 C2, C5, C6 - C9 -- 0.1uF 100V
 C3 -- 220pF clad mica
 C4 -- 15pF, ATC 700B
 C10 -- 10uF, 100V Electrolytic

L1 - VK200-4B
 L2 -- 2 Ferrite beads, 2.0 uH
 R1, R2 -- 100Ω, 2W SMT
 R3 -- 1Ω, 2W SMT
 T1 -- 9:1 Transformer
 T2 -- 1:9 Transformer

150 MHz test Circuit

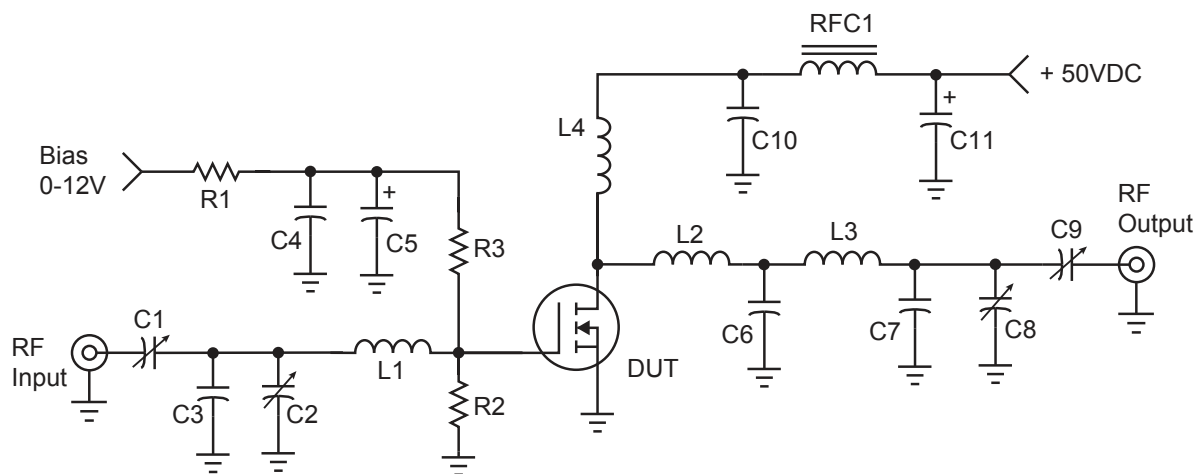

C1, C2, C8 -- Arco 463 or equivalent
 C3 -- 25pF, Unelco
 C4 -- 0.1uF, Ceramic SMT 50V
 C5 -- 1.0 uF, 15 WV Tantalum
 C6 -- 250pF, Unelco J101
 C7 -- 25pF, Unelco J101
 C9 -- Arco 262 or equivalent

C10 -- 50nF, Ceramic SMT 100V
 C11 -- 15uF, 63WV Electrolytic
 L1 -- 3/4", #18 into Hairpin
 L2 -- Printed Line, 0.200" W x 0.500" L
 L3 -- 1", #16 into Hairpin approx 16nH
 L4 -- 2 turns #16, 5/16" ID
 RFC1 - VK200-4B
 R1-R3 -- 330 Ω, 1/4W Carbon

Adding MP at the end of P/N specifies a matched pair where $V_{GS(TH)}$ is matched between the two parts. V_{TH} values are marked on the devices per the following table.

Code	Vth Range	Code 2	Vth Range
A	2.900 - 2.975	M	3.650 - 3.725
B	2.975 - 3.050	N	3.725 - 3.800
C	3.050 - 3.125	P	3.800 - 3.875
D	3.125 - 3.200	R	3.875 - 3.950
E	3.200 - 3.275	S	3.950 - 4.025
F	3.275 - 3.350	T	4.025 - 4.100
G	3.350 - 3.425	W	4.100 - 4.175
H	3.425 - 3.500	X	4.175 - 4.250
J	3.500 - 3.575	Y	4.250 - 4.325
K	3.575 - 3.650	Z	4.325 - 4.400

V_{TH} values are based on Microsemi measurements at datasheet conditions with an accuracy of 1.0%.

.5" SOE Package Outline
All Dimensions are $\pm .005$

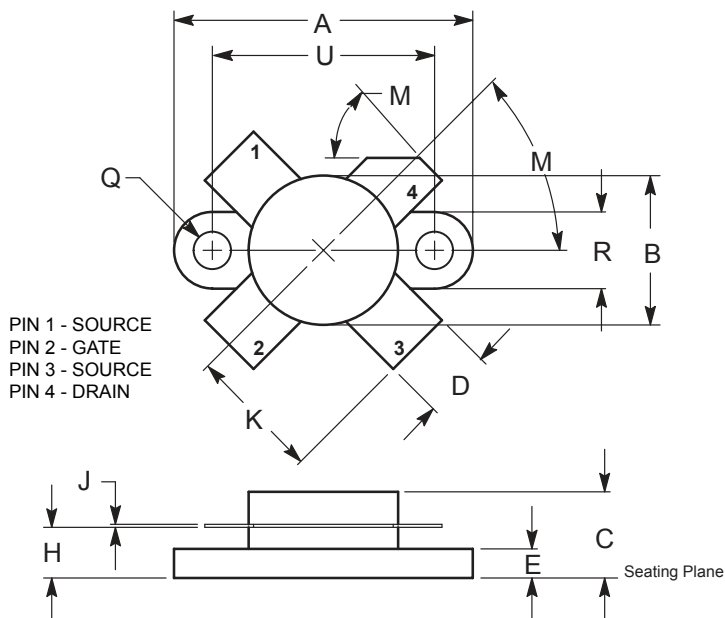

DIM	INCHES		MILLIMETERS	
	MIN	MAX	MIN	MAX
A	0.960	0.990	24.39	25.14
B	0.465	0.510	11.82	12.95
C	0.229	0.275	5.82	6.98
D	0.216	0.235	5.49	5.96
E	0.084	0.110	2.14	2.79
H	0.144	0.178	3.66	4.52
J	0.003	0.007	0.08	0.17
K	0.435		11.0	
M	45° NOM		45° NOM	
Q	0.115	0.130	2.93	3.30
R	0.246	0.255	6.25	6.47
U	0.720	0.730	18.29	18.54



Microsemi Headquarters

One Enterprise, Aliso Viejo,
CA 92656 USA
Within the USA: +1 (800) 713-4113
Outside the USA: +1 (949) 380-6100
Sales: +1 (949) 380-6136
Fax: +1 (949) 215-4996
Email: sales.support@microsemi.com
www.microsemi.com

© 2020 Microsemi. All rights reserved. Microsemi and the Microsemi logo are trademarks of Microsemi Corporation. All other trademarks and service marks are the property of their respective owners.

Microsemi makes no warranty, representation, or guarantee regarding the information contained herein or the suitability of its products and services for any particular purpose, nor does Microsemi assume any liability whatsoever arising out of the application or use of any product or circuit. The products sold hereunder and any other products sold by Microsemi have been subject to limited testing and should not be used in conjunction with mission-critical equipment or applications. Any performance specifications are believed to be reliable but are not verified, and Buyer must conduct and complete all performance and other testing of the products, alone and together with, or installed in, any end-products. Buyer shall not rely on any data and performance specifications or parameters provided by Microsemi. It is the Buyer's responsibility to independently determine suitability of any products and to test and verify the same. The information provided by Microsemi hereunder is provided "as is, where is" and with all faults, and the entire risk associated with such information is entirely with the Buyer. Microsemi does not grant, explicitly or implicitly, to any party any patent rights, licenses, or any other IP rights, whether with regard to such information itself or anything described by such information. Information provided in this document is proprietary to Microsemi, and Microsemi reserves the right to make any changes to the information in this document or to any products and services at any time without notice.

Microsemi, a wholly owned subsidiary of Microchip Technology Inc. (Nasdaq: MCHP), offers a comprehensive portfolio of semiconductor and system solutions for aerospace & defense, communications, data center and industrial markets. Products include high-performance and radiation-hardened analog mixed-signal integrated circuits, FPGAs, SoCs and ASICs; power management products; timing and synchronization devices and precise time solutions, setting the world's standard for time; voice processing devices; RF solutions; discrete components; enterprise storage and communication solutions; security technologies and scalable anti-tamper products; Ethernet solutions; Power-over-Ethernet ICs and midspans; as well as custom design capabilities and services. Microsemi is headquartered in Aliso Viejo, California, and has approximately 4,800 employees globally. Learn more at www.microsemi.com.