

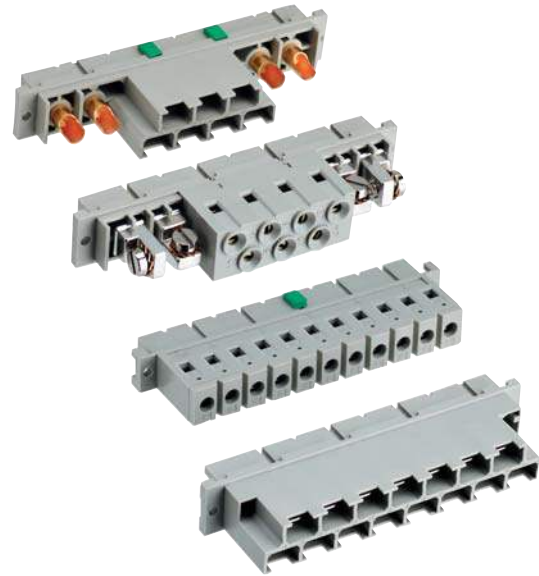

Description

All 19" cassette type converters are equipped with either H11-, H15-, H15S4, or H15S2 male connectors. Mating female connectors are available as accessories according to the following tables. The four H-type connector versions are specially designed for power supply applications, capable of handling high operating currents. The connectors have an integrated code key system allowing many coding possibilities. Converters with high output current normally use two contacts in parallel to keep the voltage drop across the connector as low as possible. In case of very high currents, the connectors are fitted with round high current contacts.



H11 Connectors

This connector has eleven contacts in one vertical column marked 2 to 32. Mating and mounting conditions are according to DIN 41612. The connector contacts are hard-silver plated and correspond to quality class 1, allowing for 500 mating cycles.

Note: H11 connectors (male version) are used in the converter series (case size): H (H02), M (M02), and PSL (L04).

Table 1: H11 Connector Survey

Female connector type	Reference	Description of terminals	Fig.	Integrated coding
STV-H11-F/CO	HZZ00101	Faston terminals 6.3 × 0.8 mm	2	yes
STV-H11-FG/CO	HZZ00196	Faston terminals 6.3 × 0.8 mm, gold-plated contacts	2	yes
STV-H11-FS/CO-G ³	HZZ00104	Faston terminals 6.3 × 0.8 mm, solderable (short moulding)	3	yes
STV-H11-FSR/CO-G	HZZ00102	Screw terminals, 90°, 2.5 mm ² (AWG 13), torque ≤ 26.6 Ncm	4	yes
STV-H11-FB/CO-G ¹	HZZ00103	Solder pin 5.2 mm, Ø 1.6 mm	5	yes
STV-H11-FBG/CO ^{1,2}	HZZ00199	Solder pin 5.2 mm, Ø 1.6 mm, gold-plated contacts	5	yes
STV-H11-FBER/CO ²	HZZ00113	Solder pin 4.3 mm, Ø 1.0 mm	5	yes
STV-H11-FP/CO ²	HZZ00111	Press fit 6.5 mm, Ø 1.0 mm	5	yes

¹ See also matching Flexi-PCB (HZZ01208) for PCB-mounting of converters, fig. 6.

² Ask Power-One for availability

³ Obsolete; use STV-H11-F/CO

Mechanical Dimensions (in mm)

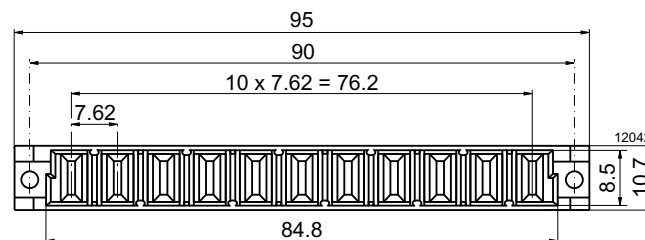

Fig. 1
H11 front view, relating to figures 2 to 5

Table of Contents

	Page		Page
Description	1	Connector Retention Brackets CRB	8
H11 Connectors	1	Connector Retention Clips V	8
H15 Connectors	3	Extraction Tool for High Current Contacts	8
H15S4, H15S2 Connectors	5	Cable Hood	9
Technical Data	7	Cable Hood Retention Brackets CHRB	9
Code Key System	7		

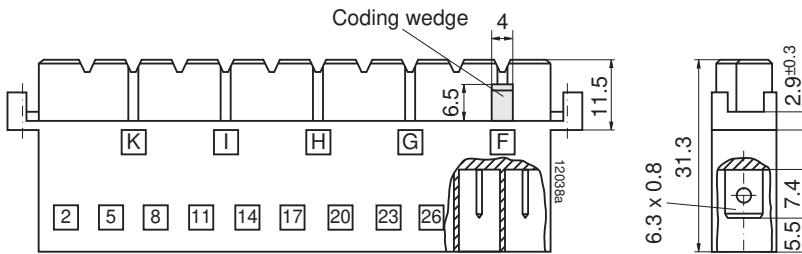

Fig. 2
STV-H11-F/CO,
Faston terminals 6.3 × 0.8 mm

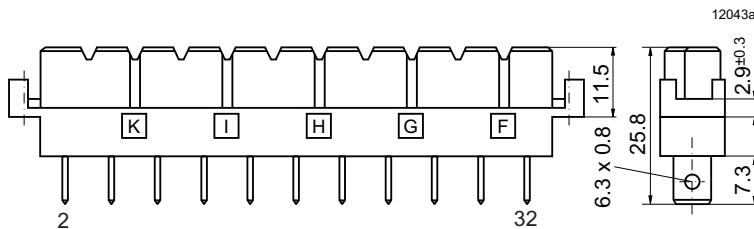

Fig. 3
STV-H11-FS/CO,
Faston terminals 6.3 × 0.8 mm, solderable (short moulding)

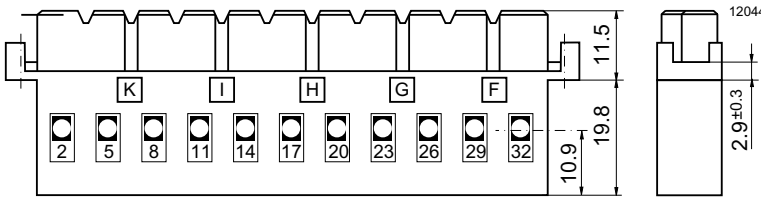

Fig. 4
STV-H11-FSR/CO,
screw terminals, max. 2.6 mm² (AWG 13)
max torque 26.6 Ncm

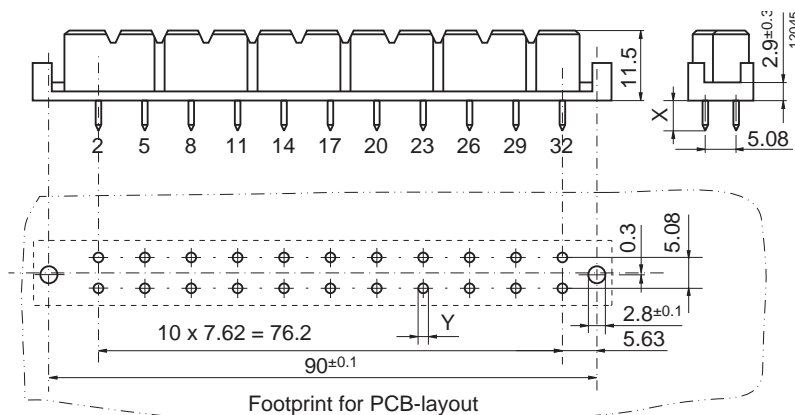

Fig. 5
STV-H11-FB/CO-G, solder pins X = 5.2 Y = Ø 1.6
STV-H11-FBG/CO, solder pins X = 5.2 Y = Ø 1.6
STV-H11-FBER/CO, solder pins X = 4.3 Y = Ø 1.0
STV-H11-FP/CO, press insert pins X = 6.5 Y = Ø 1.0



Flexible H11 PCB

If cassette style converters with male H11 connectors are mounted on a PCB board, the connection may be made using

the H11 Flexi PCB together with the female connector STV-H11-FB/CO-G [HZZ00103].

Item number: H11FLEXI-PCB [HZZ01208].

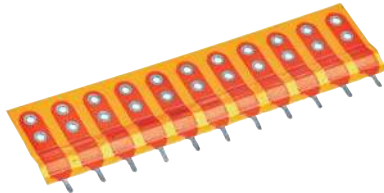
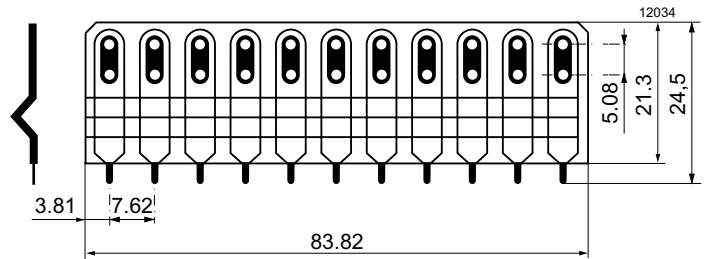

Fig. 6
Flexible H11 PCB



H15 Connectors

This connector has 15 contacts in two vertical columns, marked with 4 to 32 and is designed to meet DIN 41612. The connector contacts are hard-silver plated and correspond to

quality class 1, allowing for 500 mating cycles.

Note: This connector type (male version) is used in the following converter series (case size): Q, P, LPC, PSK, PSS, K, S, T.

Table 2: H15 Connector Survey

Female connector type	Reference	Description of terminals	Fig.	Integrated coding
STV-H15-FSR-G	HZZ00107	Screw terminals, 90°, 2.5 mm ² (AWG 13), torque ≤ 26.6 Ncm	8	no
STV-H15-F/CO-G	HZZ00106	Faston terminals 6.3 × 0.8 mm	(8)	yes
STV-H15-FB/CO	HZZ00112	Solder pin 4.0 mm, Ø 1.6 mm	9	yes
STV-H15-FBG/CO ¹	HZZ00197	Solder pin 4.0 mm, Ø 1.6 mm, gold-plated contacts	9	yes
STV-H15-FP/CO ¹	HZZ00117	Press fit 4.5 mm, Ø 1.0 mm (double-pin version)	(9)	yes
STV-H15-FWS/CO	HZZ00114	Solder pin 10.1 mm, Ø 1.6 mm, 90° bent contacts	10	yes

¹ Ask Power-One for availability

Mechanical Dimensions (in mm)

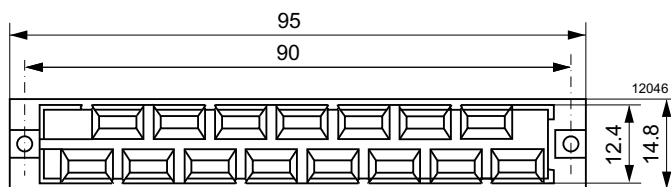

Fig. 7
H15 front view, relating to the next figures

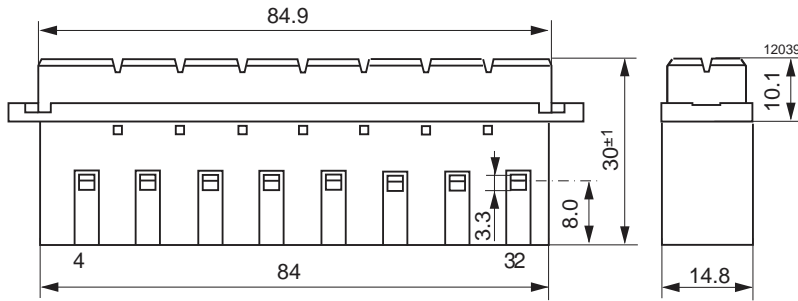

Fig. 8
STV-H15-FSR,
Screw terminals, no coding, max torque 26.6 Ncm

STV-H15-F/CO-G,
Faston terminals 6.3 × 0.8 mm (identical dimensions, but not shown). The orientation of the faston terminals can be horizontal or vertical, depending on supplier.

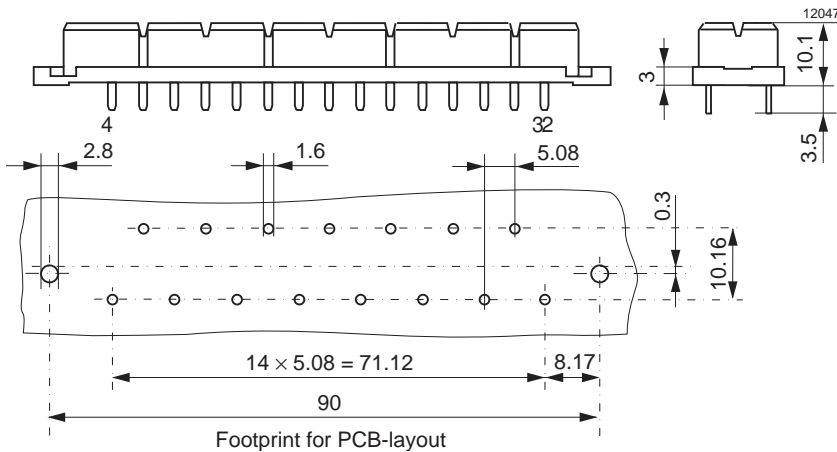

Fig. 9
STV-H15-FB/CO, solder pins

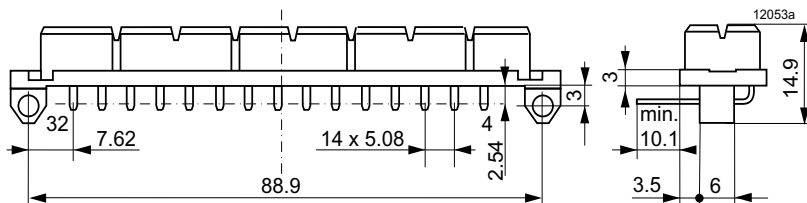

Fig. 10
STV-H15-FWS/CO, solder pins for PCB mounting



H15S4, H15S2 Connectors

These special connectors derive from the H15 connectors having standard contacts as the standard connectors, combined with 4 (H15S4) or 2 (H15S2, discontinued) high-current contacts (jacks) according to DIN 41626. These jacks are specially designed to handle currents up to 40 A. They correspond to quality class 2, allowing for 400 mating cycles. The contact material is high-quality Phosphor Bronze.

The high-current jacks are joined separately to the connectors. To install them, carefully follow the assembly instructions. It is extremely important to solder cables, screw cable terminals or heat shrink sleeves to high-current jacks first, before inserting them into the moulding. Paralleled converters should preferably be interconnected on current bars or at a star point.

Using screw versions, the two outer high-current jacks may be inserted at a 90° angle in order to prevent possible short circuits between the cable terminals, especially in applications

with high vibration environment. Heat shrink sleeves might be necessary for further isolation purposes or to keep clearances and creepage distances at specified levels.

An extraction tool allows removal of the high-current jacks for replacement (see fig. 15).

Caution: The use of an adequate cable strain relief device (e.g. Cable Hood etc.) is essential, in order to protect the high-current contact jacks from damage. Do not screw, solder or manipulate these contacts, when the connector is plugged into the male connector! The use of highly flexible cables is strongly recommended.

Note: H15S4 connectors (male version) are used in the following converter series (case size): K, PSK with line currents ≥ 20 A.

Note: H15S2 connectors (male version) are used in the following converter series (case size): P1000, K4000 with line currents ≥ 20 A. H15S2 connectors are not for new designs and will be discontinued. Please consult the product data sheets for replacing models.

Table 3: H15S2 and H15S4 connector survey

Female connector type	Reference	Description of terminals	Fig.	Integrated coding
STV-H15S2-FSF/CO ³	HZZ 00116	11 faston terminals 6.3 × 0.8 mm, 2 screw jacks ¹	11	yes
STV-H15S2-F/CO ³	HZZ 00115	11 faston terminals 6.3 × 0.8 mm, 2 solder jacks ¹	(11)	yes
STV-H15S4-FSF/CO	HZZ 00110	7 faston terminals 6.3 × 0.8 mm, 4 screw jacks ¹	13	yes
STV-H15S4-F/CO	HZZ 00105	7 faston terminals 6.3 × 0.8 mm, 4 solder jacks ¹	(13)	yes
STV-H15S4-FLS/CO ²	HZZ 00109	7 screw terminals 90°, 2.5 mm ² , torque ≤ 26.6 Ncm, 4 solder jacks ¹	14	yes
STV-H15S4-FSR/CO ²	HZZ 00108	7 screw terminals, 90°, 2.5 mm ² , torque ≤ 26.6 Ncm, 4 screw jacks ¹	(14)	yes

¹ Spare jacks are available on request: screw version YVM002, solder version XMB045; see fig. 11.

² Obsolete. Use female connectors with faston terminals instead!
³ H15S2 connectors are not for new designs and will be discontinued.

Delivery content: H15S4 (S2) moulding, 4 (2) high current jacks and assembly instructions. Screw versions also include four M4 screws with washers and heat shrink sleeves.

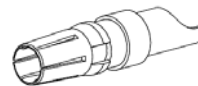

Fig. 11a
Solder jack XMB045

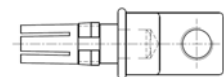

Fig. 11b
Screw jack YVM002 for screws M4.

Mechanical Dimensions (in mm)

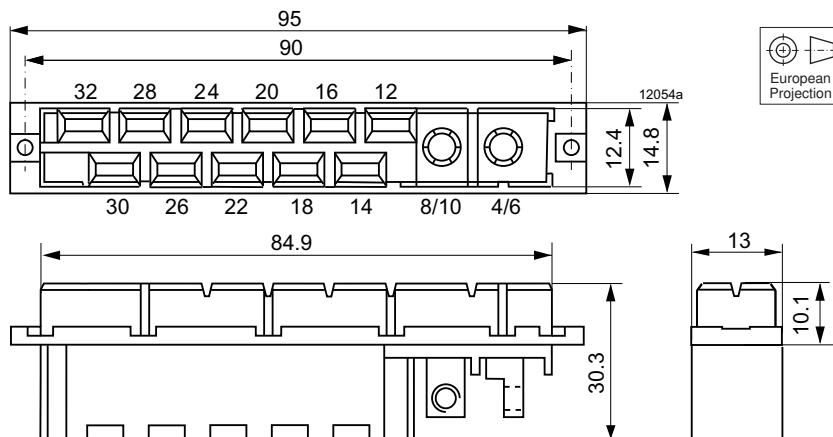

Fig. 12
STV-H15 S2-FSF/CO
11 faston terminals and two screw jacks.
STV-H15 S2-F/CO
11 faston terminals and two solder jacks (solder jacks are shown in fig. 15).

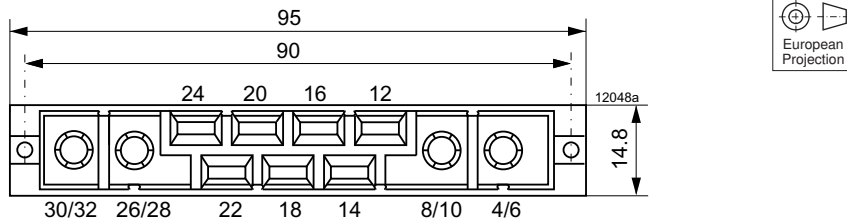

Fig. 13
H15 S4 front view, relating to figures below

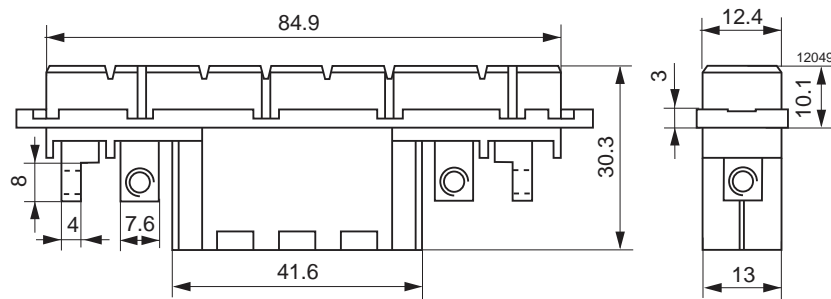

Fig. 14
STV-H15 S4-FSF/CO,
7 faston terminals and 4 screw jacks
STV-H15 S4-F/CO
7 faston terminals and 4 solder jacks (solder jacks are shown in fig. 14.)

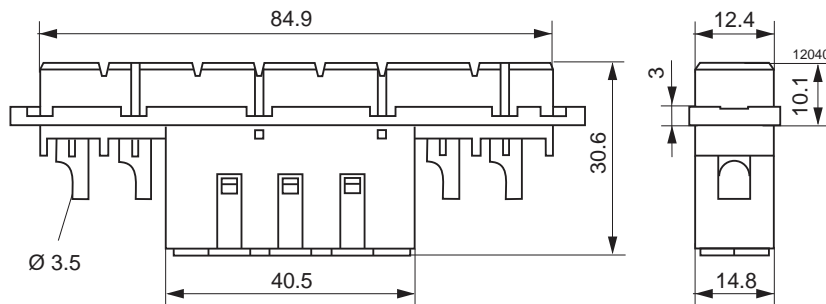

Fig. 15
STV-H15 S4-FLS/CO,
7 screw terminals (max torque 26.6 Ncm) and 4 solder jacks
STV-H15 S4-FSR/CO,
7 screw terminals (max torque 26.6 Ncm) and 4 screw jacks (screw jacks are shown in fig. 13)

The connectors with 7 screw terminals shown in fig. 14 should not be used for new designs. Use connectors with 7 faston terminals instead as shown in fig. 13.



Technical Data of Connectors

Table 4: Connector data

Mechanical data	H11	H15	H15S2/H15S4	
			Fastons	High current
Number of poles	11	15	11/7	2/4
Mating cycles	500	500	400	
Insertion/withdrawal forces max.	80 N	90 N	90 N	10/1.6 N
Electrical data				
Clearances and creepage distances contact to ground	≥ 4.5 mm	≥ 4.5 mm	≥ 4.0 mm	
Clearances and creepage distances between contacts	≥ 8.0 mm	≥ 8.0 mm	≥ 4.0 mm	
Test voltage	3100 VAC	3100 VAC	3100 VAC	
Operation voltage	500 VAC	500 VAC	500 VAC	
Operation current per contact	$T_A = 20\text{ °C}$ 20 A $T_A = 70\text{ °C}$ 17 A $T_A = 95\text{ °C}$ 14 A	15 A 12 A 9 A	15 A 12 A 9 A	40 A 35 A 25 A
Contact resistance	≤ 8 mΩ	≤ 8 mΩ	≤ 8 mΩ	≤ 1 mΩ
Insulation resistance at 100 VDC	≥ 1000 MΩ	≥ 1000 MΩ	≥ 1000 MΩ	
Miscellaneous data				
Operating temperature	-55 to 125 °C	-55 to 125 °C	-55 to 105 °C	
Contact surface	6 μ Ag	6 μ Ag	6 μ Ag over 2 μ Ni	0.8 μ Au over 2 μ Ni
Moulding material	PBT Crastin/PC	PBT Crastin/PC	30% glass-filled PBT	
Flammability	UL 94V-0/UL 94 V-1	UL 94 V-0/UL 94 V-1	UL 94 V-0	
Approvals				

Code Key System

An efficient coding system is of great importance in complex electronic systems. Since power supplies handle high currents and voltages, any false connection could be dangerous and quite costly.

This integrated polarizing system allows effortless coding by the simple insertion of coding wedges [HZZ00202] into the female connector mouldings. The corresponding counterparts, i.e., the coding tabs of the male moulding just have to be broken off to match the right female part. Major advantages are high mechanical stability and easy handling. The H11 connectors have 10 and the H15 connectors 8 coding positions. The use of coding wedges results in many different coding possibilities. Coding wedges are available as



Fig. 16
Integrated code key system for a H11 connector

accessories to female connectors with the following item number:

- Description:** Codierkeil (5X)
- Reference:** HZZ00202
- Delivery content:** 5 pcs.

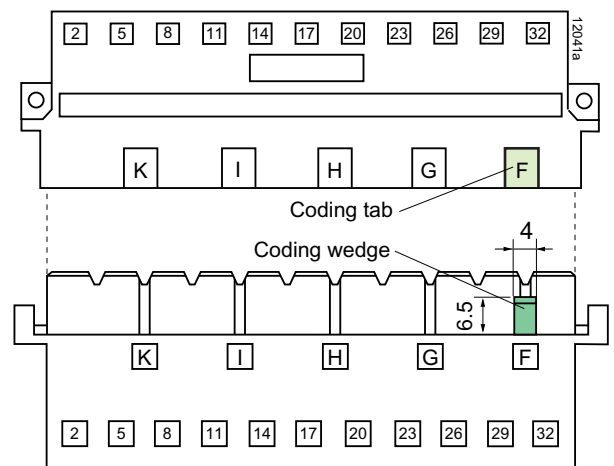

Bottom side:

Fig. 17
Integrated code key system (H15 connector)



Extraction Tool for High Current Contacts

High current plugs and jacks can be disassembled from the moulding by means of a special extraction tool (H15S2 and H15S4 connectors). Holding the extraction tool over the center of the connector's female contact the outer part of the extraction tool should be fed between the moulding and the outside of the female contact itself. This releases the spring clip fixing the contacts, in order to pull the contacts out of their moulding for replacement. If the operation is performed correctly, very little force is required. Extreme care should be taken since incorrect procedure and excessive force could damage the tool and/or the connector.

This tool is available as an accessory for high-current solder and high-current screw contacts.

Note: In order to avoid damage, never manipulate high-current contacts when plugged-in!

Description: Extraction tool
Reference: HZZ00150



Fig. 18
Extraction tool

Connector Retention Clips V

The retention clip V is an accessory, which guarantees secure connection even under severe vibration, as for example in mobile applications. One connector retention system fits to almost all converters and all of the mentioned connector types.

The following converter series are delivered with pre-punched holes in the back plate for fast field-mounting of retention clips:

Note: Suitable for H, M, K, S, PSK, PSS, PSL, and T (Q, LPC, P Series only in combination with Mounting Plate Q [HZZ01215])

Description: Retentionclip (2x)
Reference: HZZ01209
Delivery content: 2 pcs.

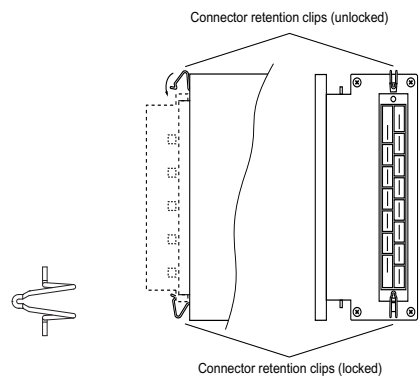

Fig. 19
Connector retention clips

Connector Retention Brackets CRB

An alternative to the above mentioned retention clip V is the connector retention bracket. They are attached to the back plate by one screw each with a torque of 20 to 30 Ncm.

Table 5: Connector Retention Bracket Survey

Connector series	Item number [Reference]	Delivery content
H, M, PSL K, PSK S, PSS T	CRB-HKMS [HZZ01216]	2 brackets 2 screws 2 washers
Q, P LPC	CRB-Q [HZZ01217]	



Fig. 20
Connector retention bracket CRB



Cable Hood

A cable connector housing or cable hood is available for all female H15, H15S2 and H15S4 type connectors with faston terminals (not suited for screw terminals). It serves as a strain relief, isolates connections and protects cables.

- Item number:** KSG-H15/H15S4
- Reference:** HZZ00141
- Delivery content:** Housing shell, cable duct with covers, cable clip, cable boot and screws

If using the cable hood together with retention clips, a special version is available, where both sides of the hood are slightly modified in order to allow for insertion of the clips. The cable hood with retention clips has been tested to withstand vibrations according to IEC/EN 60068-2-6: 5 g, 7.5 h (2.5 h per axis).

- Item number:** KSG-H15/H15S4-V
- Reference:** HZZ00142
- Delivery content:** Housing shell, cable duct with covers, cable clip, cable boot and screws

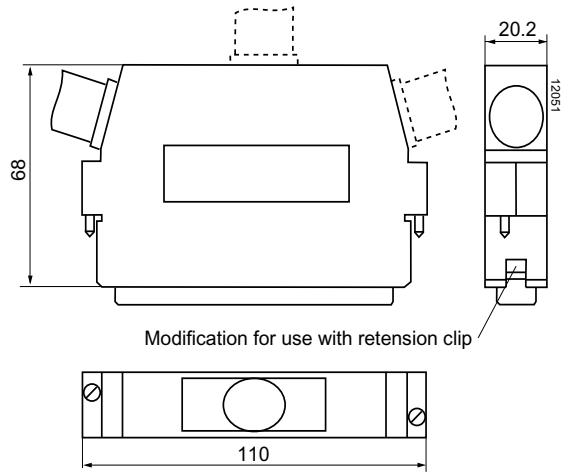

Fig. 21
Cable hood for H15 and H15S4 connectors

Cable Hood Retention Brackets CHRB

The cable hood can also be fixed to the converter case with two U-shaped cable hood retention brackets.

Note: Available for H, M, K, S, PSK, PSS, PSL, T Series.

- Item number:** CHRB-KSG
- Reference:** HZZ01218
- Delivery content:** 2 brackets with 2 screws



Fig. 22
Cable hood retention bracket CHRB

NUCLEAR AND MEDICAL APPLICATIONS - Power-One products are not designed, intended for use in, or authorized for use as critical components in life support systems, equipment used in hazardous environments, or nuclear control systems without the express written consent of the respective divisional president of Power-One, Inc.

TECHNICAL REVISIONS - The appearance of products, including safety agency certifications pictured on labels, may change depending on the date manufactured. Specifications are subject to change without notice.