

版数 REV.	年月日 DATE	DON NO.	変更内容 DESCRIPTION	製図 DR.	担当 CHK.	査閲 APPD.	承認 APPD.

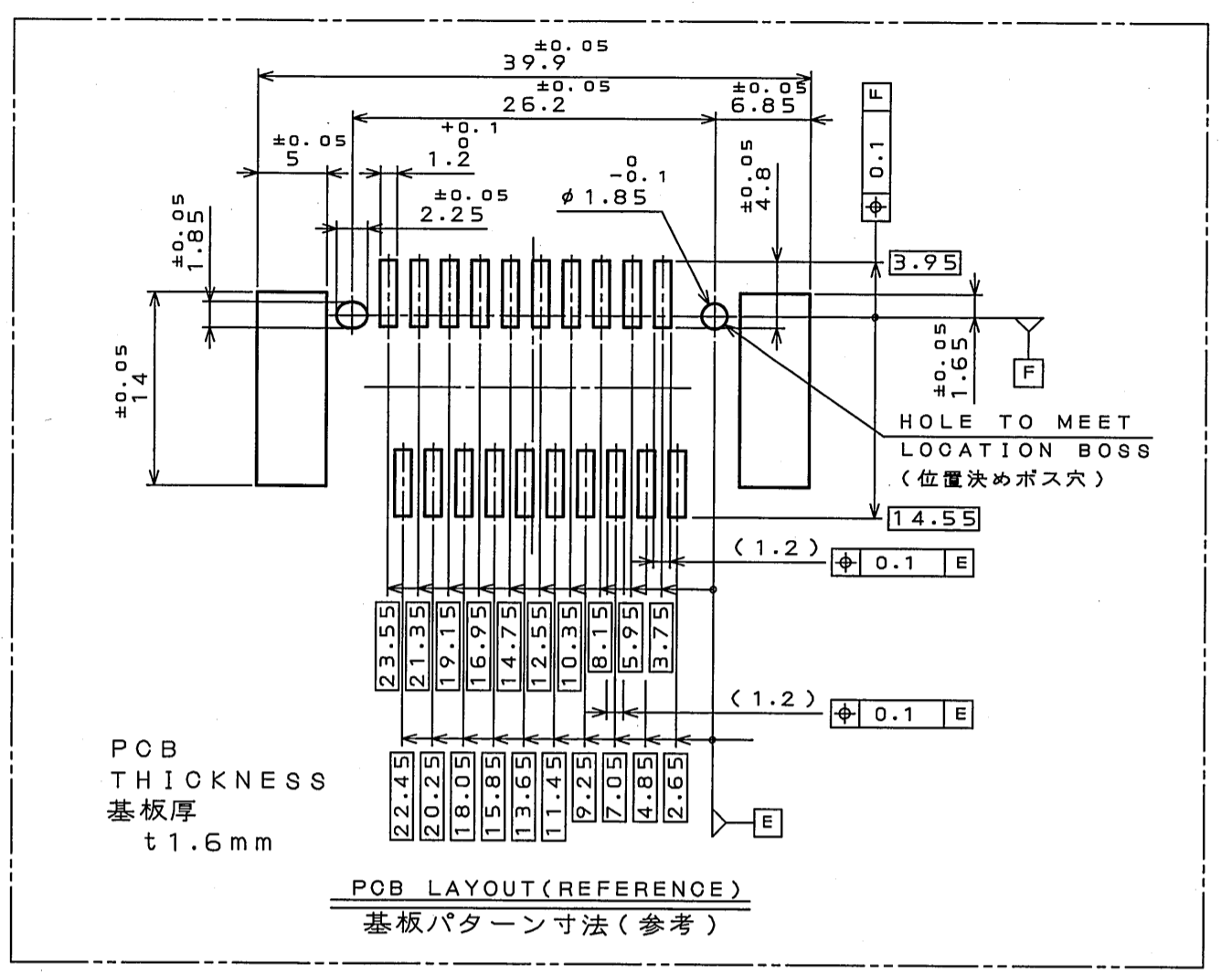
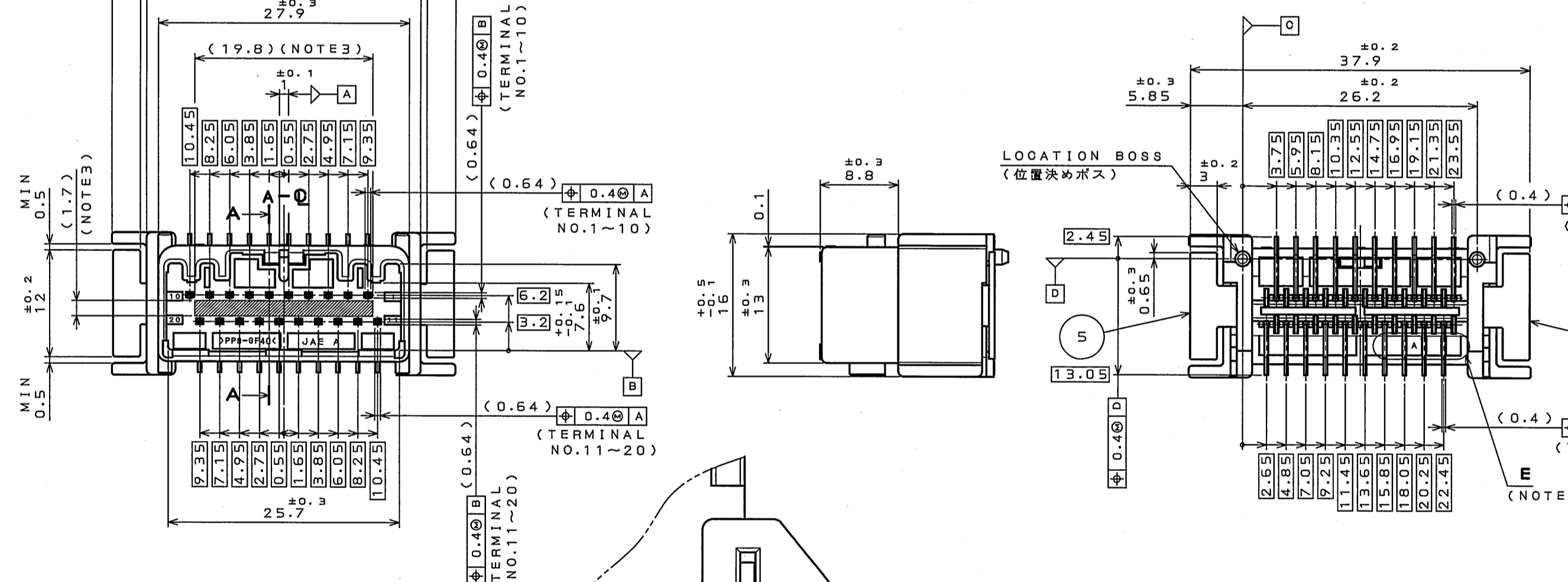
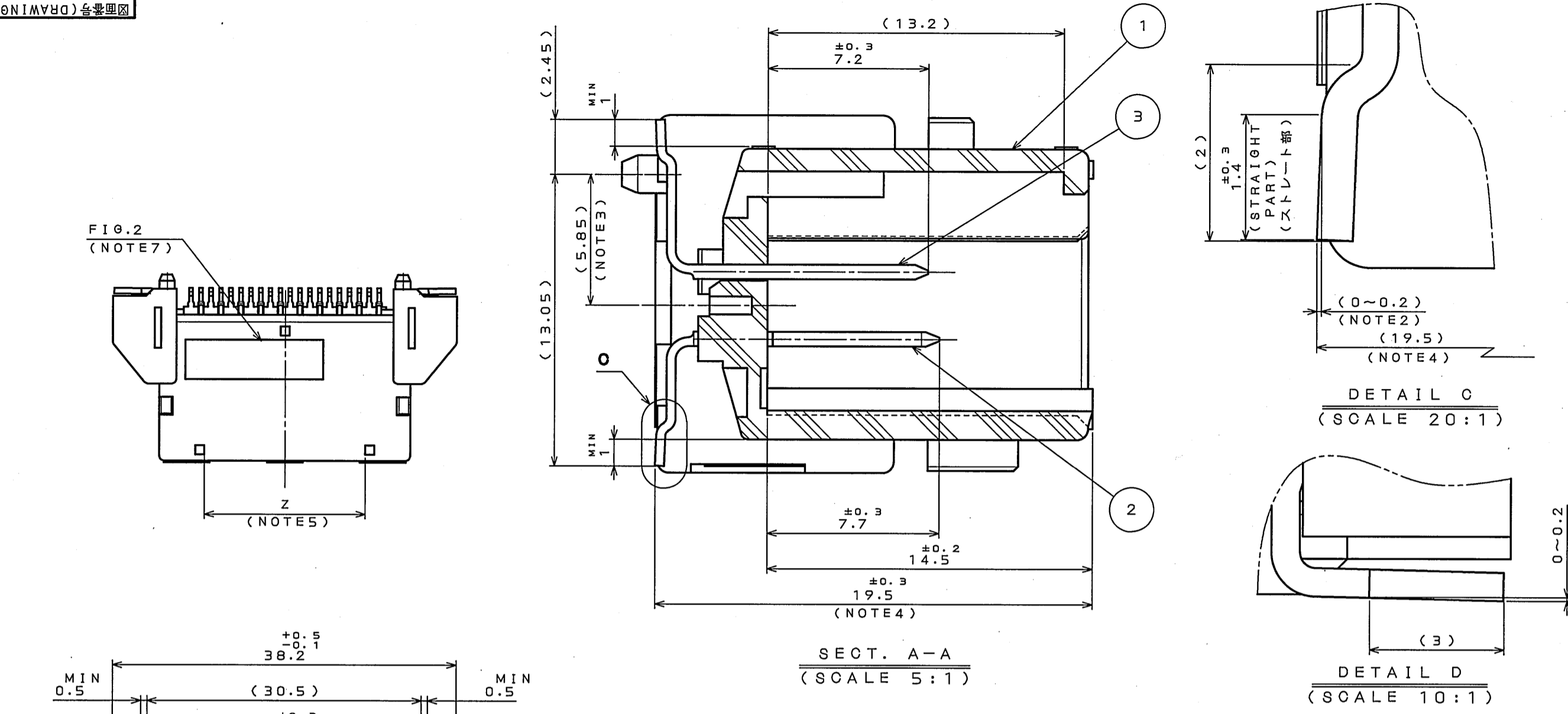

NOTE 1. THE COPLANARITY TERMINALS, INCLUDING THE HOLD-DOWNS, SHALL BE 0.15 MAX AS REFERENCED FROM THE SURFACE PLATE. (REFERENCE FIGURE 1)

2. THE TIPS OF TERMINAL SHALL BE NEARER TO THE SURFACE OF PLATE THAN THE BOTTOM SIDE. THE TIPS OF HOLD-DOWNS SHALL BE NEARER TO THE SURFACE OF PLATE THAN THE BOTTOM SIDE.

3. THIS DIMENSION INDICATES THE VACUUMED AREA OF AUTOMATED ASSEMBLY.

4. DIMENSION (19.5) SHALL BE REFERENCED FROM TIP OF TERMINAL.

5. DIMENSION Z IS 15 MIN.

6. MOLDING CAVITY DESIGNATION LOCATED IN AREA "E". INDIVIDUAL CAVITIES WILL VARY IN SHAPE DUE TO THE CAVITIES INDICATION AREA.

7. INDICATE ASSEMBLY LOT NO. AS SHOWN FIGURE 2.

注 1. 定盤基準でホールダウンを含めた端子のコプラナリティは0.15ミリ以下とする。(図1参照)

2. 端子及びホールダウン足部の根元と先端の関係は根元より先端が定盤側(0~0.2ミリ)にあること。

3. 吸着面の寸法を示す。

4. 指示寸法(19.5)は、端子最下位置からの寸法である。

5. 寸法Zは15MINとする。

6. E部は、Cav No. 認識部である為 Cav毎に形状が異なる。

7. 組立ロットNO.を刻印表示する。(表示位置を図2で示す。)

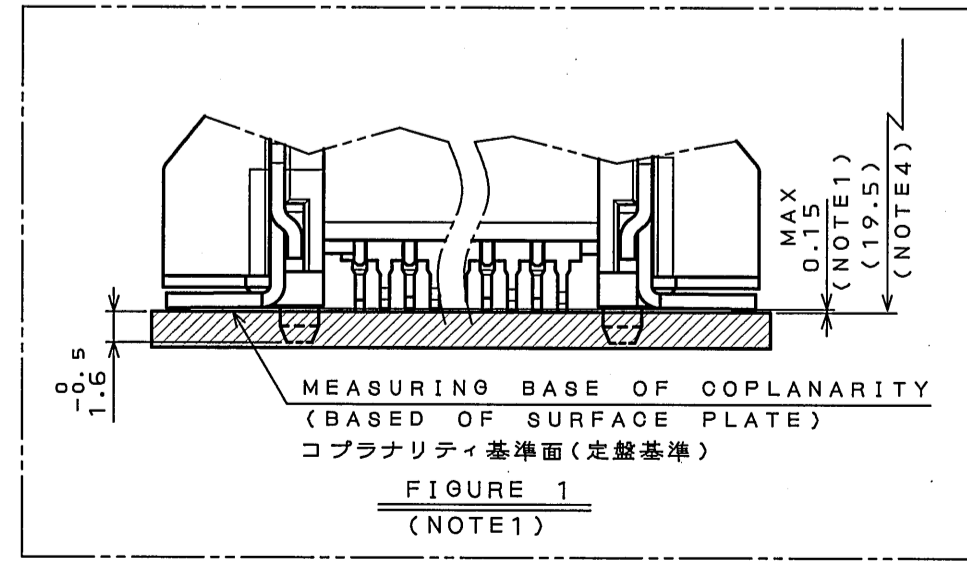

符号 NO.	名称 DESCRIPTION	個数 QTY.	材料 MATERIAL	仕上 FINISH	備考 REMARKS
5	HOLD DOWN-2	1	BRASS t=0.64	TIN PLATE OVER NICKEL	
4	HOLD DOWN-1	1	BRASS t=0.64	TIN PLATE OVER NICKEL	
3	TERMINAL-2	10	COPPER ALLOY t=0.64	TIN PLATE OVER NICKEL	
2	TERMINAL-1	10	COPPER ALLOY t=0.64	TIN PLATE OVER NICKEL	
1	HOUSING	1	PPS-GF40		COLOR: BLACK

公差(GENERAL TOLERANCE)	製図 DR.	名称(TITLE)	仕上 FINISH	備考 REMARKS
寸法(DIMENSION)	担当 CHK.	MX34R20VF1	MX34R	
角度(ANGLES)	査閲 APPD.	(PIN HEADER)		
.X ±0.4	承認 APPD.			
.XX ±0.1				
.XXX ±				

仕様書(SPECIFICATION)	第1版(ORIGINAL DATE)	尺数(SCALE)	シリーズ(SERIES)	
JAOS-1754-10	23.Oct.2007	2:1	MX34R	
JAHL-1754				

製図 DR.	担当 CHK.	名称(TITLE)	仕上 FINISH	備考 REMARKS
	S. TAKEDA K. NOZAWA	MX34R20VF1	MX34R	
	K. Miyamoto	(PIN HEADER)		
	T. Kume			

図面番号(DRAWING NO.)	版数 (REV.)
SJ106351	1

DDF-0-213F(05.08)

