

To our customers,

Old Company Name in Catalogs and Other Documents

On April 1st, 2010, NEC Electronics Corporation merged with Renesas Technology Corporation, and Renesas Electronics Corporation took over all the business of both companies. Therefore, although the old company name remains in this document, it is a valid Renesas Electronics document. We appreciate your understanding.

Renesas Electronics website: <http://www.renesas.com>

April 1st, 2010
Renesas Electronics Corporation

Issued by: Renesas Electronics Corporation (<http://www.renesas.com>)

Send any inquiries to <http://www.renesas.com/inquiry>.

Not recommended
for new design

Notice

1. All information included in this document is current as of the date this document is issued. Such information, however, is subject to change without any prior notice. Before purchasing or using any Renesas Electronics products listed herein, please confirm the latest product information with a Renesas Electronics sales office. Also, please pay regular and careful attention to additional and different information to be disclosed by Renesas Electronics such as that disclosed through our website.
2. Renesas Electronics does not assume any liability for infringement of patents, copyrights, or other intellectual property rights of third parties by or arising from the use of Renesas Electronics products or technical information described in this document. No license, express, implied or otherwise, is granted hereby under any patents, copyrights or other intellectual property rights of Renesas Electronics or others.
3. You should not alter, modify, copy, or otherwise misappropriate any Renesas Electronics product, whether in whole or in part.
4. Descriptions of circuits, software and other related information in this document are provided only to illustrate the operation of semiconductor products and application examples. You are fully responsible for the incorporation of these circuits, software, and information in the design of your equipment. Renesas Electronics assumes no responsibility for any losses incurred by you or third parties arising from the use of these circuits, software, or information.
5. When exporting the products or technology described in this document, you should comply with the applicable export control laws and regulations and follow the procedures required by such laws and regulations. You should not use Renesas Electronics products or the technology described in this document for any purpose relating to military applications or use by the military, including but not limited to the development of weapons of mass destruction. Renesas Electronics products and technology may not be used for or incorporated into any products or systems whose manufacture, use, or sale is prohibited under any applicable domestic or foreign laws or regulations.
6. Renesas Electronics has used reasonable care in preparing the information included in this document, but Renesas Electronics does not warrant that such information is error free. Renesas Electronics assumes no liability whatsoever for any damages incurred by you resulting from errors in or omissions from the information included herein.
7. Renesas Electronics products are classified according to the following three quality grades: “Standard”, “High Quality”, and “Specific”. The recommended applications for each Renesas Electronics product depends on the product’s quality grade, as indicated below. You must check the quality grade of each Renesas Electronics product before using it in a particular application. You may not use any Renesas Electronics product for any application categorized as “Specific” without the prior written consent of Renesas Electronics. Further, you may not use any Renesas Electronics product for any application for which it is not intended without the prior written consent of Renesas Electronics. Renesas Electronics shall not be in any way liable for any damages or losses incurred by you or third parties arising from the use of any Renesas Electronics product for an application categorized as “Specific” or for which the product is not intended where you have failed to obtain the prior written consent of Renesas Electronics. The quality grade of each Renesas Electronics product is “Standard” unless otherwise expressly specified in a Renesas Electronics data sheets or data books, etc.
 - “Standard”: Computers; office equipment; communications equipment; test and measurement equipment; audio and visual equipment; home electronic appliances; machine tools; personal electronic equipment; and industrial robots.
 - “High Quality”: Transportation equipment (automobiles, trains, ships, etc.); traffic control systems; anti-disaster systems; anti-crime systems; safety equipment; and medical equipment not specifically designed for life support.
 - “Specific”: Aircraft; aerospace equipment; submersible repeaters; nuclear reactor control systems; medical equipment or systems for life support (e.g. artificial life support devices or systems), surgical implantations, or healthcare intervention (e.g. excision, etc.), and any other applications or purposes that pose a direct threat to human life.
8. You should use the Renesas Electronics products described in this document within the range specified by Renesas Electronics, especially with respect to the maximum rating, operating supply voltage range, movement power voltage range, heat radiation characteristics, installation and other product characteristics. Renesas Electronics shall have no liability for malfunctions or damages arising out of the use of Renesas Electronics products beyond such specified ranges.
9. Although Renesas Electronics endeavors to improve the quality and reliability of its products, semiconductor products have specific characteristics such as the occurrence of failure at a certain rate and malfunctions under certain use conditions. Further, Renesas Electronics products are not subject to radiation resistance design. Please be sure to implement safety measures to guard them against the possibility of physical injury, and injury or damage caused by fire in the event of the failure of a Renesas Electronics product, such as safety design for hardware and software including but not limited to redundancy, fire control and malfunction prevention, appropriate treatment for aging degradation or any other appropriate measures. Because the evaluation of microcomputer software alone is very difficult, please evaluate the safety of the final products or system manufactured by you.
10. Please contact a Renesas Electronics sales office for details as to environmental matters such as the environmental compatibility of each Renesas Electronics product. Please use Renesas Electronics products in compliance with all applicable laws and regulations that regulate the inclusion or use of controlled substances, including without limitation, the EU RoHS Directive. Renesas Electronics assumes no liability for damages or losses occurring as a result of your noncompliance with applicable laws and regulations.
11. This document may not be reproduced or duplicated, in any form, in whole or in part, without prior written consent of Renesas Electronics.
12. Please contact a Renesas Electronics sales office if you have any questions regarding the information contained in this document or Renesas Electronics products, or if you have any other inquiries.

(Note 1) “Renesas Electronics” as used in this document means Renesas Electronics Corporation and also includes its majority-owned subsidiaries.

(Note 2) “Renesas Electronics product(s)” means any product developed or manufactured by or for Renesas Electronics.

HA16107P/FP, HA16108P/FP

PWM Switching Regulator for High-performance Voltage Mode Control

REJ03F0141-0400
(Previous: ADE-204-012C)
Rev.4.00
Jun 15, 2005

Description

The IC products in this series are primary control switching regulator control IC's appropriate for obtaining stabilized DC voltages from commercial AC power.

These IC's can directly drive power MOS FET's, they have a timer function built in to the secondary overcurrent protection, and they can perform intermittent operation or delayed latched shutdown as protection operations in unusual conditions. They can be used to implement switching power supplies with a high level of safety due to the wide range of built-in functionality.

Functions

- 6.45 V reference voltage
- Triangle wave generator
- Error amplifier
- Under voltage lockout protector
- PWM comparator
- Pulse-by-pulse current limiting
- Timer-latch current limiting (HA16107)
- ON/OFF timer function (HA16108)
- Soft start and quick shutdown
- Output circuit for power MOS FET driving

Features

- Operating frequencies up to a high 600 kHz
- Built-in pre-driver circuit for driving power MOS FET
- Built-in timer latch over-current protection function (HA16107)
- The OCL enables intermittent operation by an ON/OFF timer for prevention of secondary overcurrent. (HA16108)
- The UVL function (under voltage lockout) is applied to both V_{in} and V_{ref} .
- ON/OFF reset: an auto-reset function which is based on the time constant of an external capacitor and observation of drops in V_{in} .
- Since the over-voltage protection function OVP (the TL pin) only observes voltage drops in V_{in} , it is possible to use the OVP and ON/OFF pin for independent purposes.
- Built-in 34 V Zener diode between V_{in} and ground.

Ordering Information

| Product | Typical Threshold Voltage | | Notes | Package Code (Previous Code) |
|-----------|---------------------------|-----------|----------------------------|---------------------------------|
| | UVL1 | OVP | | |
| HA16107P | Hi: 16.2 V | 7.0 V | Timer latch protection | DP-16 |
| HA16107FP | Lo: 9.5 V | | | PRSP0016DH-A (FP-16DA) |
| HA16108P | Hi: 16.2 V | Hi: 7.0 V | On-off timer protection | DP-16 |
| HA16108FP | Lo: 9.5 V | Lo: 1.3 V | | PRSP0016DH-A (FP-16DA) |

Pin Arrangement

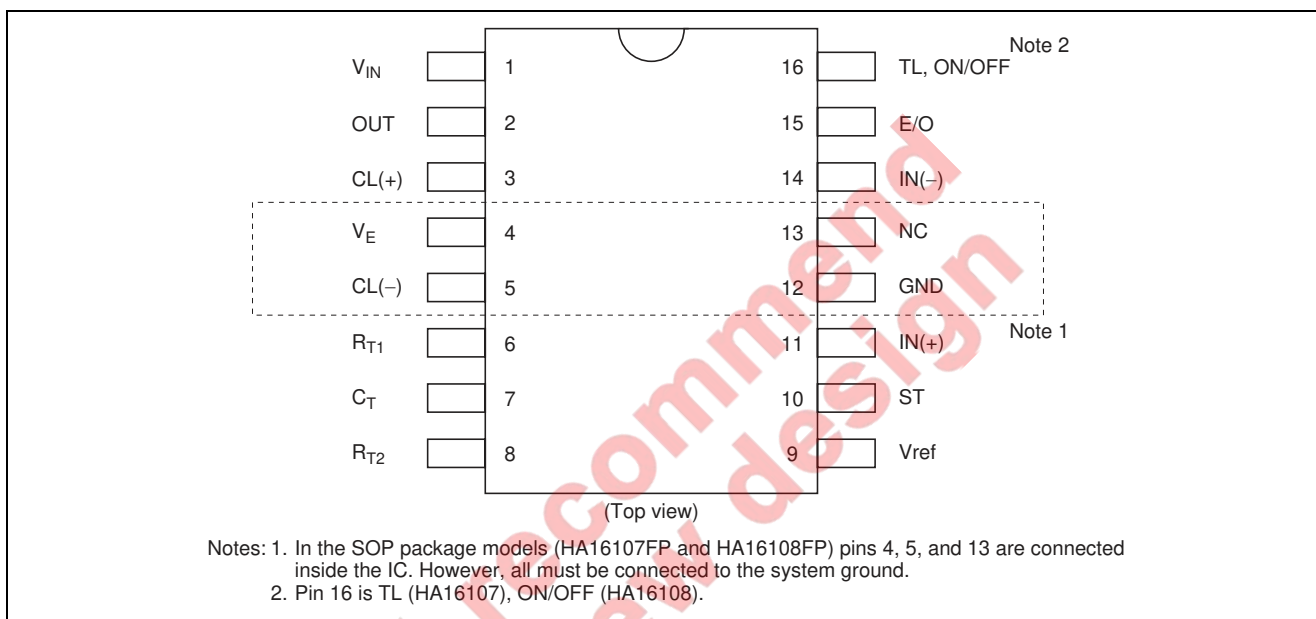

Pin Functions

- HA16107P, HA16108P

| Pin No. | Symbol | Pin Functions |
|---------|------------|---|
| 1 | V_{IN} | Input voltage |
| 2 | OUT | Pulse output |
| 3 | CL (+) | Current limiter |
| 4 | V_E | Output ground |
| 5 | CL (-) | Current limiter |
| 6 | R_{T1} | Timing resistor (rising time) |
| 7 | C_T | Timing capacitor |
| 8 | R_{T2} | Timing resistor (falling time) |
| 9 | Vref | Reference voltage output |
| 10 | ST | Soft start |
| 11 | IN (+) | Error amp (+) input |
| 12 | GND | Ground |
| 13 | NC | NC |
| 14 | IN (-) | Error amp (-) input |
| 15 | E/O | Error output |
| 16 | TL, ON/OFF | Timer latch (HA16107), ON/OFF (HA16108) |

- HA16107FP, HA16108FP

| Pin No. | Symbol | Pin Functions |
|---------|------------|---|
| 1 | V_{IN} | Input voltage |
| 2 | OUT | Pulse output |
| 3 | CL (+) | Current limiter |
| 4 | GND | Ground |
| 5 | GND | Ground |
| 6 | R_{T1} | Timing resistor (rising time) |
| 7 | C_T | Timing capacitor |
| 8 | R_{T2} | Timing resistor (falling time) |
| 9 | Vref | Reference voltage output |
| 10 | ST | Soft start |
| 11 | IN (+) | Error amp (+) input |
| 12 | GND | Ground |
| 13 | GND | Ground |
| 14 | IN (-) | Error amp (-) input |
| 15 | E/O | Error output |
| 16 | TL, ON/OFF | Timer latch (HA16107), ON/OFF (HA16108) |

Block Diagram

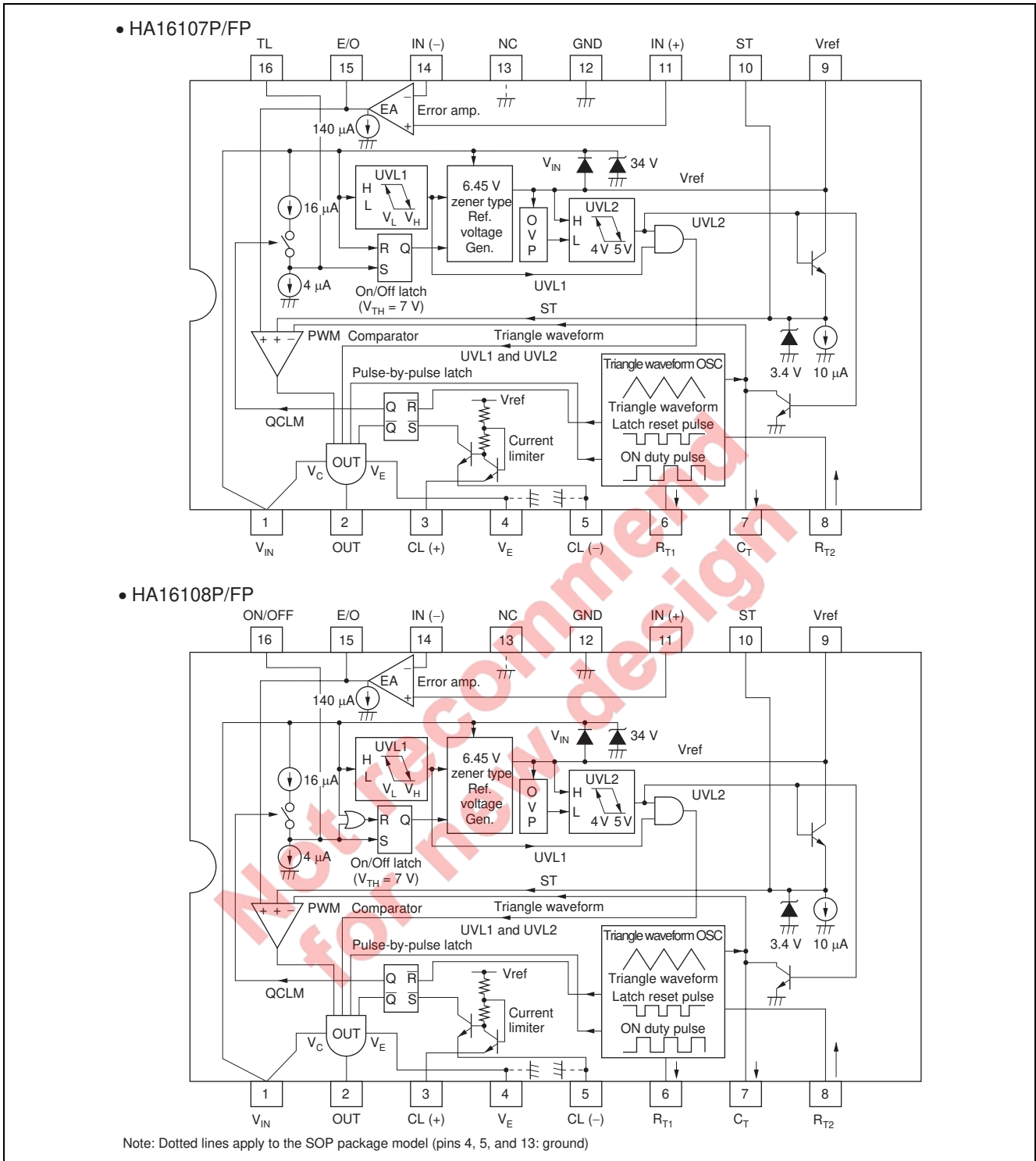

Function and Timing Chart

Triangle Waveform and PWM Output

- Timing chart (during normal operation)

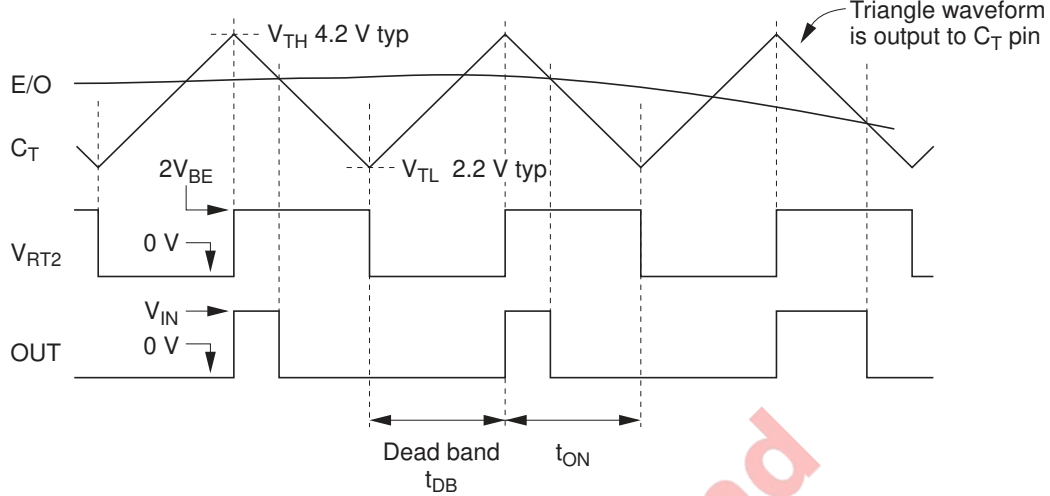

- Oscillator equivalent circuit

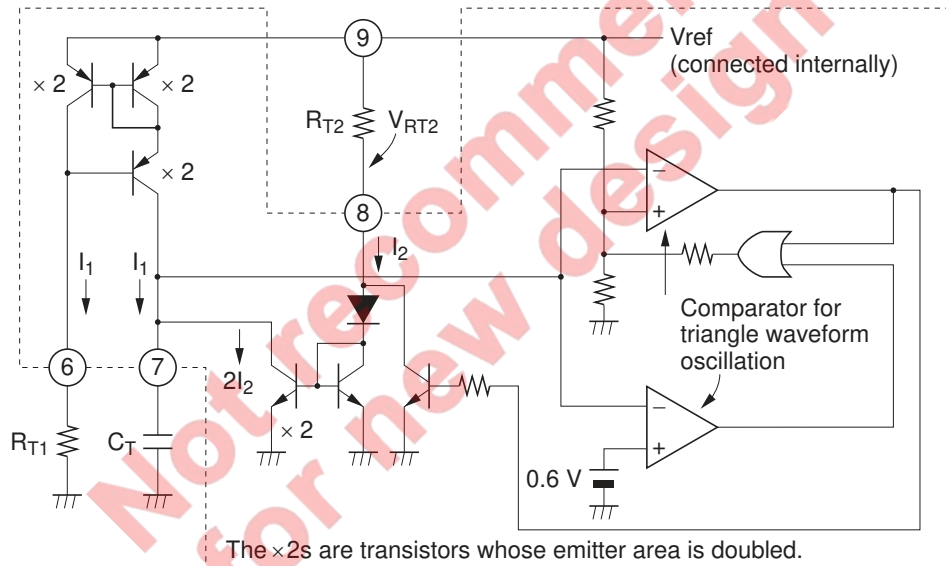

$$I_1 = \frac{V_{ref} - 2V_{BE}}{R_{T1}} \quad t_{DB} = \frac{C_T \times R_{T1} \times 2V}{V_{ref} - 2V_{BE}} \approx 0.4 \times C_T \times R_{T1} \text{ (s)} \quad Du_{max} = \frac{R_{T2}}{2R_{T1}}$$

$$I_2 = \frac{V_{ref} - 2V_{BE}}{R_{T2}} \quad t_{ON} \approx t_{DB} \frac{R_{T2}}{2R_{T1} - R_{T2}} \text{ (s)} \quad f_{OSC} \approx \frac{1 - Du_{max}}{t_{DB}} \text{ (Hz)}$$

Note: When f_{OSC} is high, the actual value will differ from that given by the formula due to the delay time. Determine the correct constants after constructing a test circuit.

1. Timing in Normal Operation

Timing in these ICs is based on a triangular voltage waveform. The rising edge (leading edge) defines the deadband time t_{DB} . The falling edge (trailing edge) defines the ON-duty control band t_{ON} . PWM output is on in the area within t_{ON} that is bounded above by the triangle wave V_{CT} and error output $V_{E/O}$.

The following pin outputs are related to PWM control:

- C_T (pin 7): triangle-wave voltage output
- E/O (pin 15): error output voltage
- R_{T2} (pin 8): ON-duty pulse output voltage
- OUT (pin 2): PWM pulse output (for driving the gate of a power MOS FET)

2. Triangle Oscillator, Waveform and Frequency

The triangle oscillator in these ICs generates a triangular waveform by charging and discharging timing capacitor C_T with a constant current, as shown in the equivalent circuit. The C_T charge current is:

$$I(C_{T\text{chg}}) = I_1 = \frac{V_{REF} - 2V_{BE}}{R_{T1}}$$

The discharge current is:

$$I(C_{T\text{dischg}}) = 2I_2 - I_1, \text{ where } I_2 = \frac{V_{REF} - 2V_{BE}}{R_{T2}}$$

In these equations V_{ref} (reference voltage) is typically 6.45 V, and V_{BE} (base-emitter voltage of internal transistors) is about 0.7 V.

The deadband time is:

$$t_{DB} = \frac{C_T \times R_{T1} \times 2V}{V_{REF} - 2V_{BE}} + 0.25 \mu\text{s}$$

$$\approx 0.4 \times C_T \times R_{T1} + 0.25 \mu\text{s}$$

The ON-duty time is:

$$t_{ON} = t_{DB} \times \frac{R_{T2}}{2R_{T1} - R_{T2}}$$

The 0.25 μs in these equations is a correction term for internal circuit delays.

The maximum ON-duty is

$$Du \text{ max} = \frac{R_{T2}}{2R_{T1}}$$

The oscillating frequency is:

$$f_{OSC} = \frac{1}{\frac{0.4 C_T R_{T1} + 0.25 \mu}{1 - \frac{R_{T2}}{2R_{T1}}} + 0.25 \mu}$$

$$= \frac{1}{\frac{0.8 C_T R_{T1}^2 + 0.25 \mu \times 2R_{T1}}{2R_{T1} - R_{T2}} + 0.25 \mu} \text{ (Hz)}$$

When $R_{T1} = R_{T2}$, the maximum ON-duty is 50%, and:

$$f_{OSC} \approx \frac{1}{0.8 C_T R_{T1} + 0.25 \mu \times 2 + 0.25 \mu}$$

$$= \frac{1}{0.8 C_T R_{T1} + 0.75 \mu} \text{ (Hz)}$$

This approximation is fairly close, but it should be checked in-circuit.

3. Programming of Maximum ON-Duty (Du Max)

The preceding equations should be used to program the deadband or maximum ON-duty. The following table gives a summary.

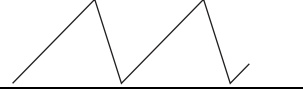
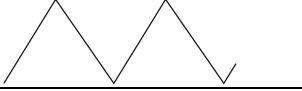
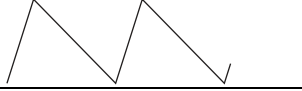
| Condition | $R_{T1} > R_{T2}$ | $R_{T1} = R_{T2}$ | $R_{T1} < R_{T2}$ |
|-------------------|---|--|---|
| Triangle waveform |  |  |  |
| Du max | Less than 50% | 50% | Greater than 50%* |

Note: In a primary-control switching regulator, Du Max > 50% is dangerous because the transformer will saturate.

Soft Start and Quick Shutdown

One purpose of the soft-start function is to protect the switching controller and power MOS FET from surges at power-up. Another purpose is to let the secondary-side DC voltage rise smoothly.

When power goes off, the quick-shutdown function rapidly discharges the capacitor in the soft-start circuit (and at the same time switches the PWM output off) to prepare for the next power-on.

The soft-start function in these ICs lets the PWM output develop smoothly from zero to the designated pulse width at power-up. The soft-start voltage is the 3.8 V voltage value of an internal Zener diode, so the PWM output is able to start widening gradually as soon as the soft-start function starts operating. The soft-start function will start promptly even if C_{ST} is large.

The soft-start and quick-shutdown modes are selected automatically in the IC, under control of the UVL signal.

Not recommended for new design

• Timing waveforms

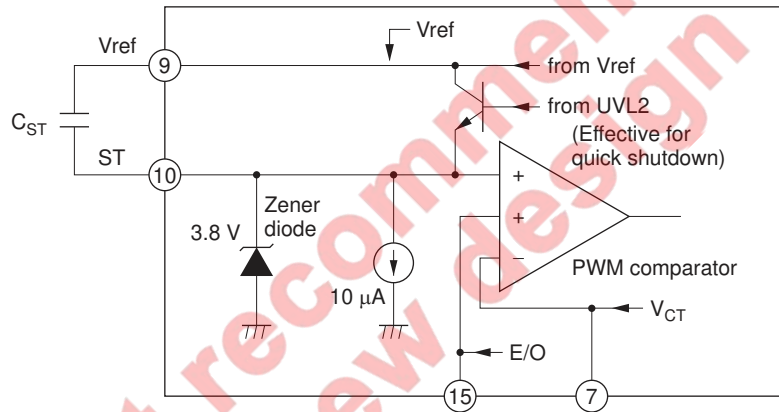
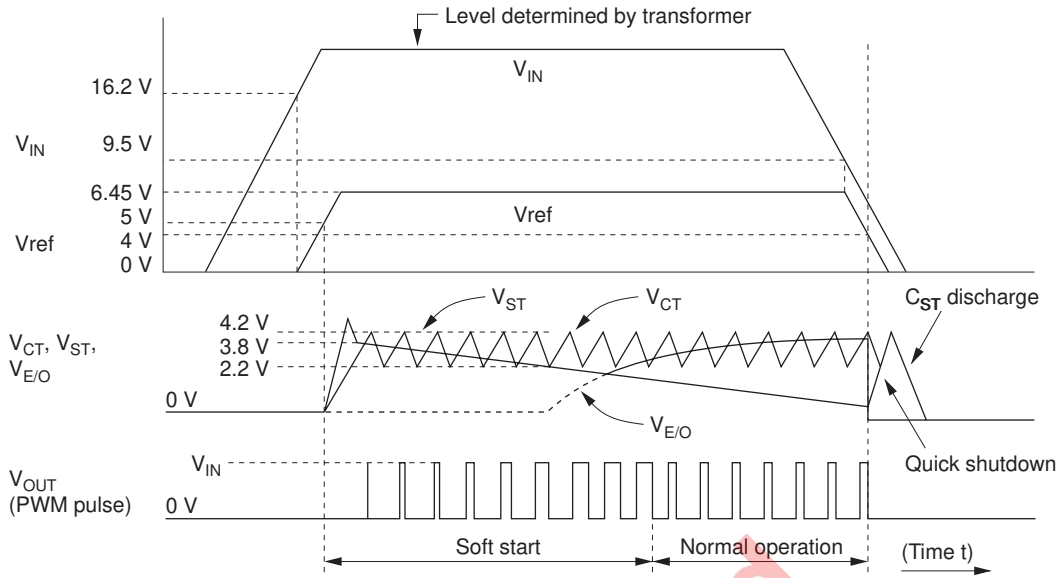

Note: The soft-start time constant is determined by C_{ST} and the constant-current value (typically 10 μA).

Vref Protection Functions: Overvoltage and Undervoltage

Vref overvoltage and undervoltage conditions are detected by the overvoltage detection circuit and UVL2 circuit. PWM output shuts down when $V_{ref} \geq 8\text{ V}$. UVL2 detects undervoltage with hysteresis between approximately 4 V and 5 V. PWM output also shuts down below these voltages. It follows that PWM output will shut off whenever the Vref pin is shorted to the power supply (V_{IN}) or ground (GND). PWM output also shuts off when V_{IN} is turned on or off.

The following diagram shows how these protection functions operate when power comes on and goes off ($V_{ref} < 6.45\text{ V}$), and when a high external voltage is applied to the Vref pin ($V_{ref} > 6.45\text{ V}$).

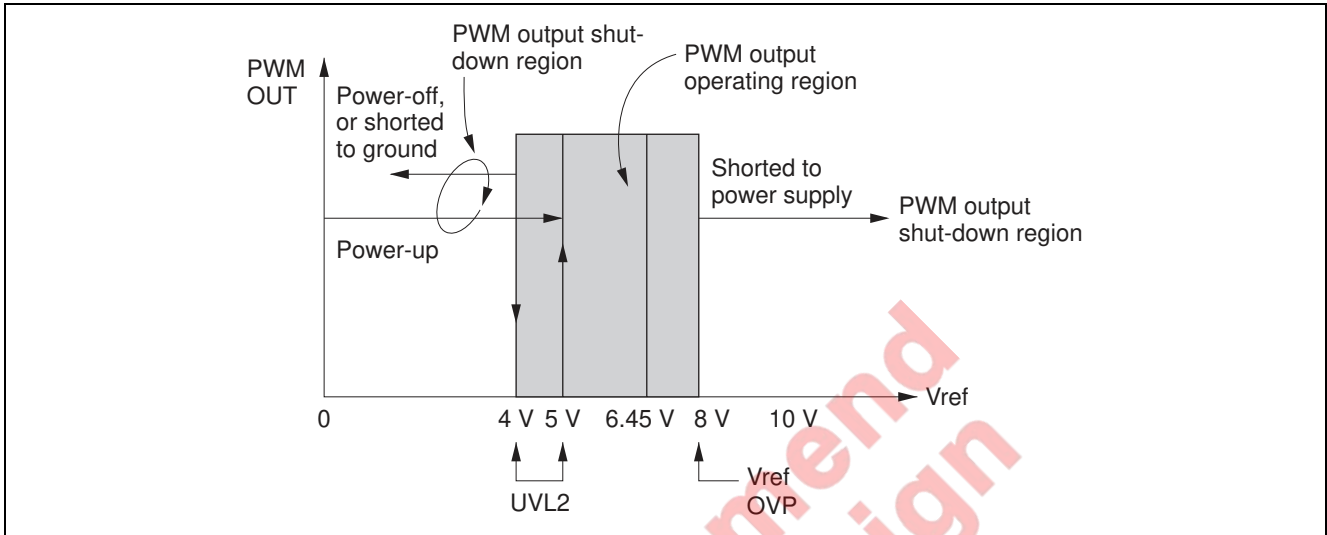

1. Current-Limiter Circuit

The current limiter pin (CL) is connected to the emitter of an npn transistor, as shown in the block diagram. The threshold voltage is 240 mV typ. The switching speed of this circuit is approximately 100 ns from detection of overcurrent to shut-down of PWM output. Switching speed increases with the strength of the signal input to the CL pin.

Instead of simple pulse-by-pulse current limiting, in these ICs the current limiting circuit is linked to the timer-and-latch or ON/OFF timer circuit, and also detects the degree of overcurrent. The overcurrent value is determined from the point at which current limiting is triggered in the ON-duty cycle. With a large overcurrent (causing current limiting to operate even at a small ON-duty), the IC automatically shortens the timer time.

Undervoltage Lockout and PWM Output

The undervoltage lockout function turns off the PWM pulse output when the controller's supply voltage goes below a designated value. These ICs have two undervoltage lockout circuits. The UVL1 circuit senses the supply voltage V_{IN} . The UVL2 circuit senses the V_{ref} voltage. A feature of these ICs is that PWM output is turned on only when both voltages are above designated values. Otherwise, the IC operates in standby mode.

The two built-in undervoltage lockout circuits make it possible to configure an extremely safe power supply system. PWM output will shut down under a variety of abnormal conditions, such as if V_{ref} is shorted to ground while V_{IN} is applied.

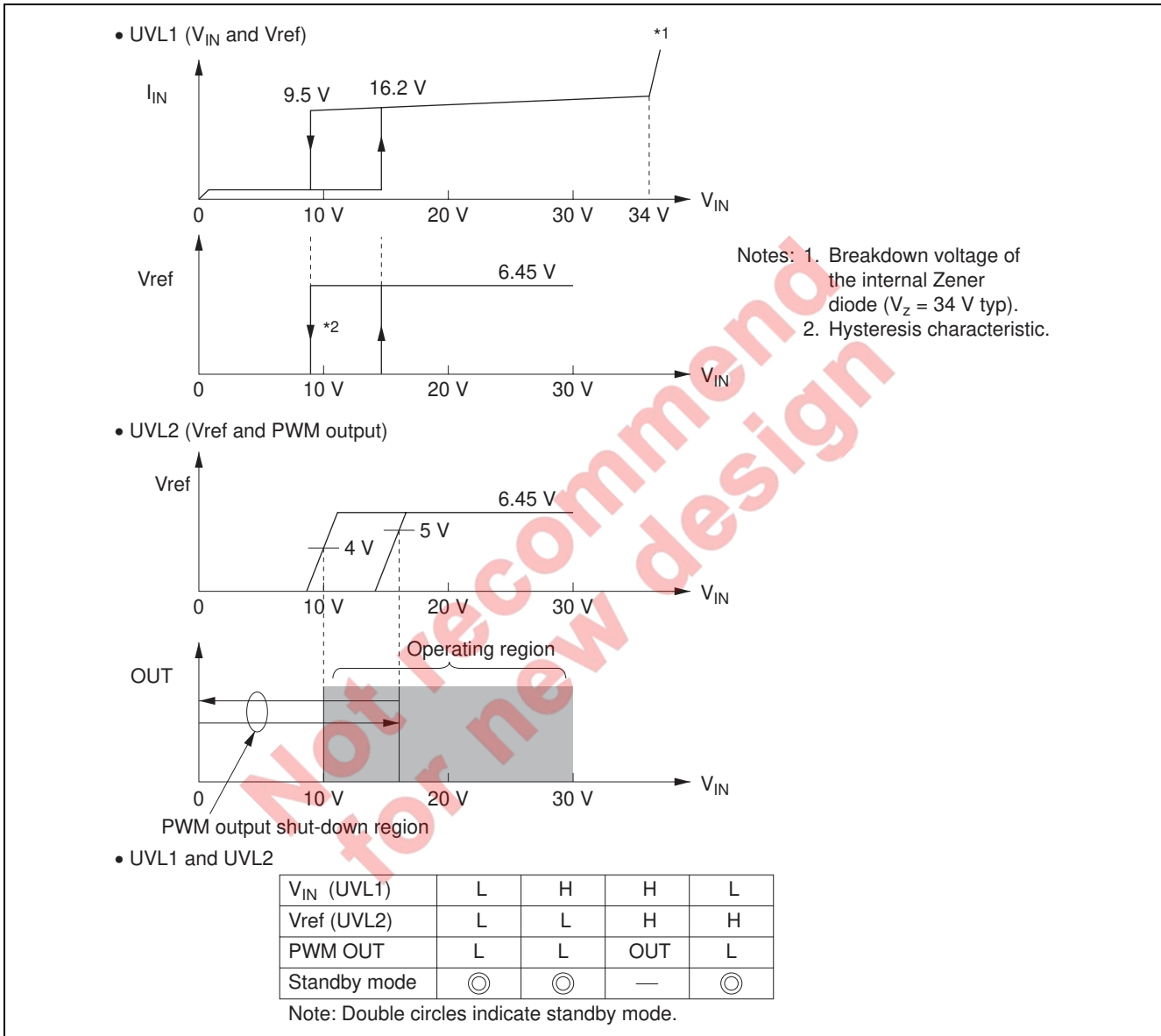

Timer Latch and ON/OFF Timer

The HA16107 has a built-in timer-latch function. The HA16108 has a built-in ON/OFF timer function.

The timer-latch function is an overvoltage protection function that combines latched shutdown of PWM output with a timer function to vary the time until latched shutdown occurs according to the overcurrent value. A dedicated voltage detection pin is provided in addition to Vref overvoltage protection.

The ON/OFF timer function is equivalent to the above timer-latch function without the latch. If overcurrent is detected continuously, PWM output shuts down temporarily, then normal operation resumes. This process repeats, temporary shutdown alternating with normal operation.

Both the timer-latch function in the HA16107 and the ON/OFF function in the HA16108 wait for an interval after overcurrent detection before shutting down PWM output. The interval is determined by capacitor C_{TM} and the value of the charge/discharge current supplied internally from the IC. Normal operation therefore continues if a single overcurrent spike is detected, while if continuous overcurrent is detected, the current and voltage droop curves for the secondary-side output have sharp characteristics.

1. Use of Timer-Latch Pin (HA16107)

— Timer-Latch Usage

See external circuit 1 in the following diagram. Under continuous overcurrent, the CML switch turns on, charging C_{TM} with 12 μA. PWM output shuts down when the voltage at pin 15 exceeds 7 V.

— Overvoltage Protection Usage

See external circuit 2 in the diagram. This configuration is suitable when overvoltage is detected by an OVP signal received through an optocoupler from the DC output on the secondary side of an AC/DC converter. PWM output shuts down when the OVP signal allows the voltage at the TL pin to exceed 7 V. The shutdown is latched. V_{IN} must go below approximately 6.5 V (V_{INR2}) to release the latched state.

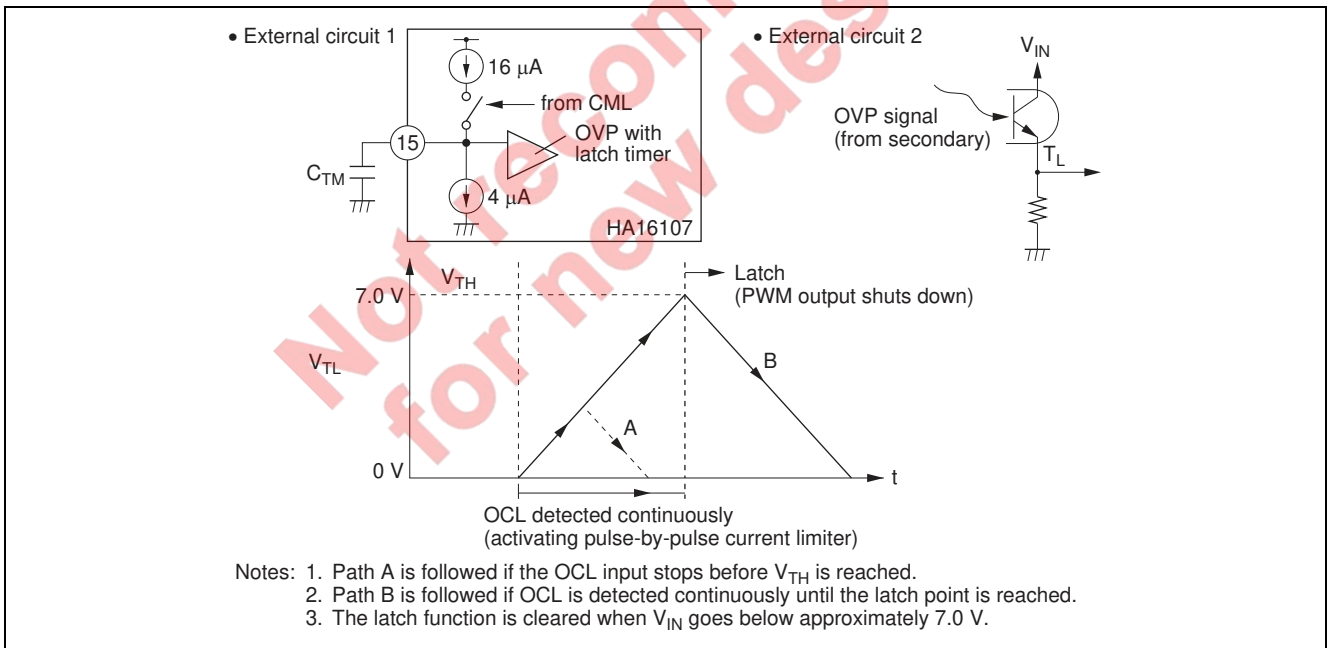

2. Use of ON/OFF Timer Pin (HA16108)

— External Circuit

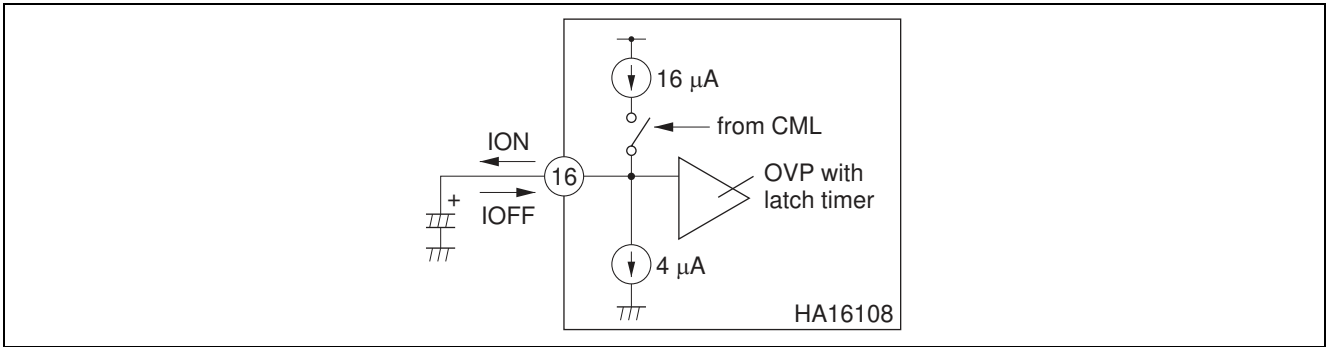

— ON/OFF Timer Operation

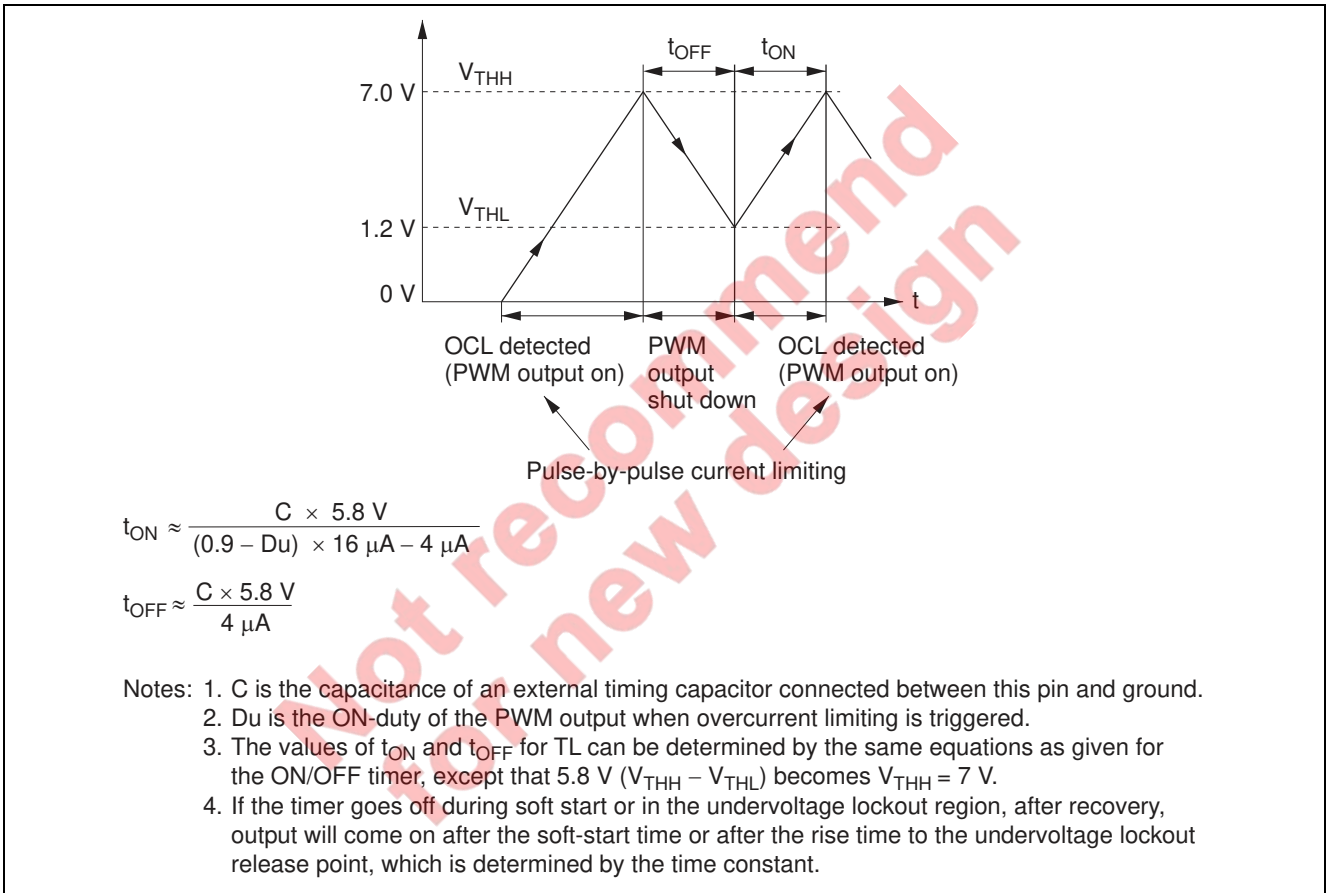

Absolute Maximum Ratings

(Ta = 25°C)

| Item | Symbol | Rating Value | Units | Notes |
|-----------------------------|--------------------|------------------|-------|-------|
| Supply voltage | V _{IN} | 30 | V | |
| Output current (DC) | I _O | ±0.2 | A | |
| Output current (peak) | I _{opeak} | ±2 | A | |
| Current limiter voltage | V _{CL} | +4, -1 | V | |
| Error amp input voltage | V _{IEA} | V _{ref} | V | |
| E/O output voltage | V _{IE/O} | V _{ref} | V | |
| R _{T1} pin current | I _{RT1} | 500 | ∞A | |
| R _{T2} pin current | I _{RT2} | 5 | mA | |
| Power dissipation | P _T | 680 | mW | 1, 2 |
| Operating temperature range | T _{opr} | -20 to +85 | °C | |
| Storage temperature range | T _{stg} | -55 to +125 | °C | |

- Notes:
1. For the "FP" products (SOP package), this value is when mounted on a 40 by 40 by 1.6 mm glass epoxy substrate. However, this value must be derated by 8.3 mW/°C from Ta = 45°C. When the wiring density is 10%, and 11.1 mW/°C from Ta = 64°C when the wiring density is 30%.
 2. For the "P" products (DIP package), this value is valid up to 45°C, and must be derated by 8.3 mW/°C above 45°C.
 3. In the case of SOP, use center 4 pins, (4), (5), (12), (13) for solder-mounting and connect the wide ground pattern, because these pins are available for heat sink of this IC.

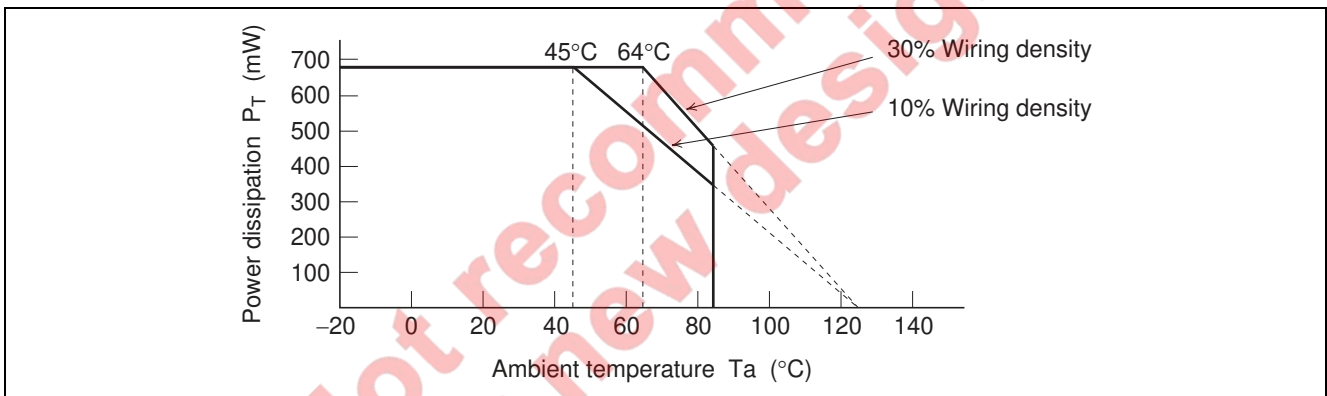

Electrical Characteristics

(Ta = 25°C, V_{IN} = 18 V, f_{OSC} = 100 kHz)

| Section | Item | Symbol | Min | Typ | Max | Unit | Test Conditions | Note |
|-------------------------|--|------------------------|------------------------|--------|------------------------|--------|---|------|
| Reference voltage | Output voltage | V _{ref} | 6.10 | 6.45 | 6.80 | V | | |
| | Line regulation | Line | – | 30 | 60 | mV | 12 V ≤ V _{IN} ≤ 30 V | |
| | Load regulation | Load | – | 30 | 60 | mV | 0 mA ≤ I _O ≤ 10 mA | |
| | Temperature stability | ΔV _{ref} /ΔTa | – | 40 | – | ppm/°C | | |
| | Short circuit current | I _{OS} | 30 | 50 | – | mA | V _{ref} = 0 V | |
| | Over voltage protection (V _{ref} OVP voltage) | V _{rov} | 7.4 | 8.0 | 9.0 | V | | |
| Triangle wave generator | Maximum frequency | f _{max} | 600 | – | – | kHz | | |
| | Minimum frequency | f _{min} | – | – | 1 | kHz | | |
| | Voltage stability | Δf/f _{o1} | – | ±1 | ±3 | % | 12 V ≤ V _{IN} ≤ 30 V f _{o1} = (f _{max} + f _{min})/2 | |
| | Temperature stability | Δf/f _{o2} | – | ±1 | – | % | –20°C ≤ Ta ≤ +85°C f _{o2} = (f _{max} + f _{min})/2 | |
| | Frequency accuracy | f _{OSC} | 270 | 300 | 330 | kHz | R _{T1} = R _{T2} = 27 kΩ C _T = 120 pF | |
| PWM comparator | Minimum deadband pulse width | t _{DB} | – | – | 1.0 | ∞s | | |
| | Low level threshold voltage | V _{TL} | 1.9 | 2.2 | 2.5 | V | | |
| | High level threshold | V _{TH} | 3.8 | 4.2 | 4.6 | V | | |
| | Differential threshold | ΔV _{TH} | 1.7 | 2.0 | 2.3 | V | | |
| | Deadband width initial accuracy | ΔDB1 | – | ±1 | ±3 | % | R _{T1} = R _{T2} = 27 kΩ C _T = 470 pF | |
| | Deadband width voltage stability | ΔDB2 | – | ±0.2 | ±2.0 | % | 12 V ≤ V _{IN} ≤ 30 V (D _{max} – D _{min})/2 | |
| | Deadband width temperature stability | ΔDB3 | – | ±1 | – | % | –20°C ≤ Ta ≤ +85°C (D _{max} – D _{min})/2 | |
| Error amp | Input offset voltage | V _{IO} | – | 2 | 10 | mV | | |
| | Input bias current | I _{IB} | – | 0.8 | 2.0 | ∞A | | |
| | Input sink current | I _{OSINK} | 80 | 140 | – | ∞A | V _O = 2 V | |
| | Output source current | I _{OSOURCE} | 80 | 140 | – | ∞A | V _O = 5 V | |
| | High level output voltage | V _{OH} | V _{ref} – 1.5 | – | – | V | I _O = 10 ∞A | |
| | Low level output voltage | V _{OL} | – | – | 0.5 | V | I _O = 10 ∞A | |
| | Voltage gain | G _V | – | 55 | – | dB | f = 10 kHz | |
| | Band width | BW | – | 15 | – | MHz | | |
| | (–) Common mode voltage | V _{CM–} | 1.2 | – | – | V | | |
| | (+) Common mode voltage | V _{CM+} | – | – | V _{ref} – 1.5 | V | | |
| | Over-current detector | (+) Threshold voltage | V _{TH+} | 0.216 | 0.240 | 0.264 | V | |
| (+) Bias current | | I _{B+} | – | 180 | 250 | ∞A | V _{CL+} = 0 V | |
| (–) Threshold voltage | | V _{TH–} | –0.264 | –0.240 | –0.216 | V | | 1, 2 |
| (–) Bias current | | I _{B–} | – | 950 | 1350 | ∞A | V _{CL–} = –0.3 V | 1, 2 |
| Response time | | t _{off} | – | 100 | – | ns | CL; open V _{CL} = +0.35 V | |

Notes: 1. Only applies to the HA16107P, HA16108P
2. The terminal should not be applied under –1.0 V.

Electrical Characteristics (cont.)

(Ta = 25°C, V_{IN} = 18 V, f_{OSC} = 100 kHz)

| Section | Item | Symbol | Min | Typ | Max | Unit | Test Conditions | Note |
|------------------------------|---|---------------------|-----------------------|------|------|------|---|------|
| Soft start | High level voltage | V _{STH} | 3.2 | 3.8 | 4.4 | V | I _{sink} = 1 mA | |
| | Sink current | I _{sink} | 7 | 10 | 13 | ∞A | V _{ST} = 2.0 V | |
| Under voltage lockout 1 | V _{IN} high level threshold voltage | V _{INTH} | 14.7 | 16.2 | 17.7 | V | | |
| | V _{IN} low level threshold voltage | V _{INTL} | 8.5 | 9.5 | 10.5 | V | | |
| | Threshold differential voltage | ΔV _{TH} | 5.2 | 6.2 | 7.2 | V | (V _{INTH} - V _{INTL}) | |
| Under voltage lockout 2 | V _{ref} high level threshold voltage | V _{rTH} | 4.5 | 5.0 | 5.5 | V | | |
| | V _{ref} low level threshold voltage | V _{rTL} | 3.5 | 4.0 | 4.5 | V | | |
| Timer latch, ON/OFF timer *2 | Latch threshold voltage | V _{THH} | 6.5 | 7.0 | 7.5 | V | Latch threshold voltage | |
| | V _{IN} reset voltage | V _{INR2} | 6.0 | 6.5 | 7.0 | V | | |
| | Reset voltage | V _{THL2} | 1.0 | 1.3 | 1.6 | V | | 1 |
| | Differential threshold to UVL low voltage | ΔV | 2.0 | 3.0 | — | V | (V _{INTL} - V _{INR2}) | |
| | Source current (OCL mode) | I _{source} | 8 | 12 | 16 | ∞A | Over current detection mode | |
| | Sink current (latch mode) | I _{sink} | 2.5 | 4 | 5.5 | ∞A | TL(ON/OFF) terminal = 4 V | |
| Output | Low voltage | V _{OL1} | — | 1.7 | 2.2 | V | I _{osink} = 0.2 A | |
| | High voltage | V _{OH} | V _{IN} - 2.2 | — | — | V | I _{osource} = 0.2 A | |
| | Low voltage (standby mode) | V _{OL2} | — | — | 0.5 | V | I _{osink} = 1 mA | |
| | Rising time | t _r | — | 40 | — | ns | C _L = 1000 pF | |
| | Falling time | t _f | — | 60 | — | ns | C _L = 1000 pF | |
| Total | Standby current | I _{st} | — | 160 | 250 | ∞A | V _{IN} = 14 V | |
| | Operation current | I _{IN1} | — | 16 | 20 | mA | V _{IN} = 30 V, C _L = 1000 pF, f = 100 kHz | |
| | Operation current | I _{IN2} | — | 12 | 16 | mA | V _{IN} = 30 V, f = 100 kHz, Output open | |
| | ON/OFF latch current | I _{IN3} | — | 350 | 460 | ∞A | V _{IN} = 14 V | |
| | V _{IN} - GND Zener voltage | V _Z | 30 | 34 | — | V | | |

Notes: 1. Only applies to the HA16108P/FP.

2. Timer latch: HA16107P/FP.

ON/OFF timer: HA16108P/FP.

Note on Standby Current

In the test circuit shown in figure 1, the operating current at the start of PWM pulse output is the standby current.

If the resistance connected externally to the Vref pin (including R_{T2}) is smaller than that of the test circuit, the apparent standby current will increase.

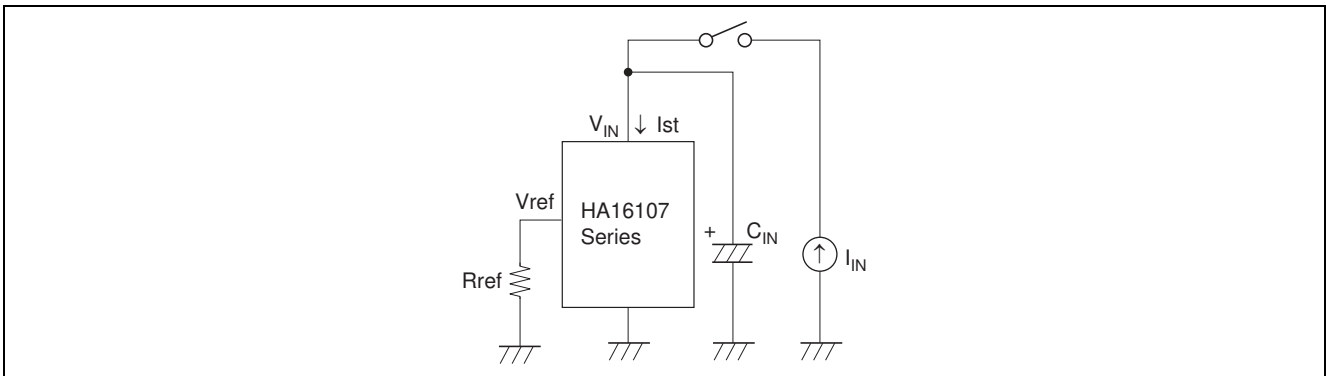

Figure 1 Standby Current Test Circuit

Not recommended
for new design

Application Note

- Case:
When DC power is applied directly as the power supply of the HA16107/HA16108, without using the transformer backup coil.
- Phenomenon:
The IC may not be activated in the case of a circuit in which V_{IN} rises quickly ($10\text{ V}/100\ \mu\text{s}$ or faster), such as that shown in figure 2.
- Reason:
Because of the IC circuit configuration, the timer latch block operates first.
- Remedy (counter measure):
Take remedial action such as configuring a time constant circuit as shown in figure 3, to keep the V_{IN} rise speed below $10\text{ V}/100\ \mu\text{s}$.

If the IC power supply consists of an activation resistance and backup coil, as in an AC/DC converter, The V_{IN} rise speed is usually around $1\text{ V}/100\ \mu\text{s}$, and there is no risk of this phenomenon occurring.

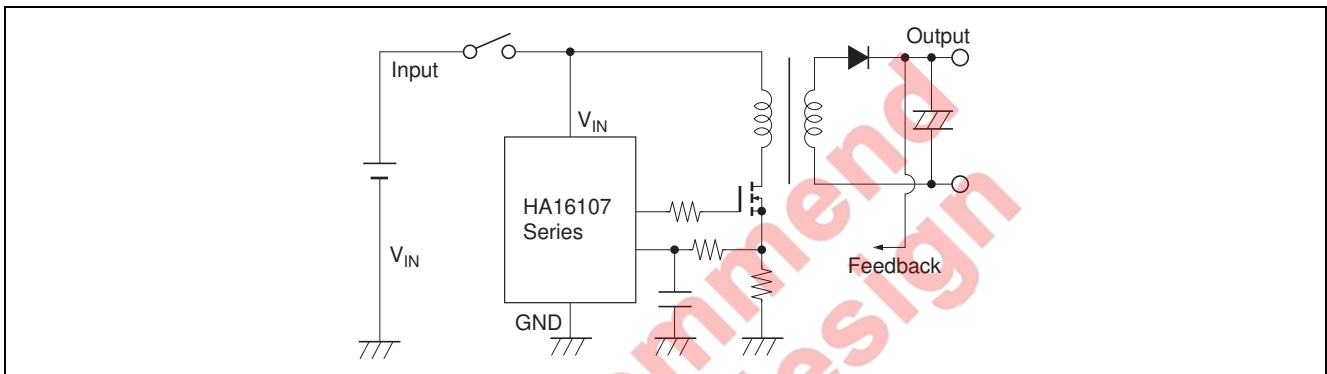

Figure 2 Example of Circuit with Fast V_{IN} Rise Time

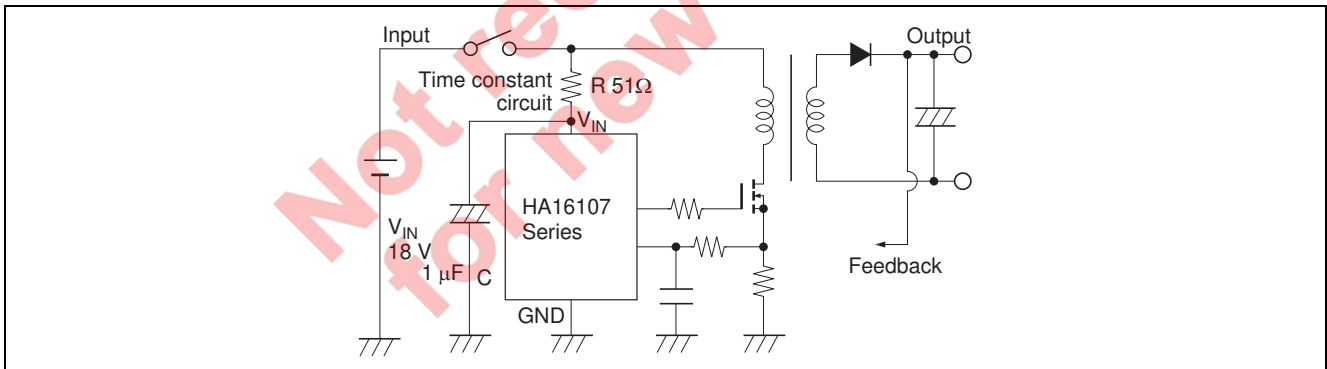
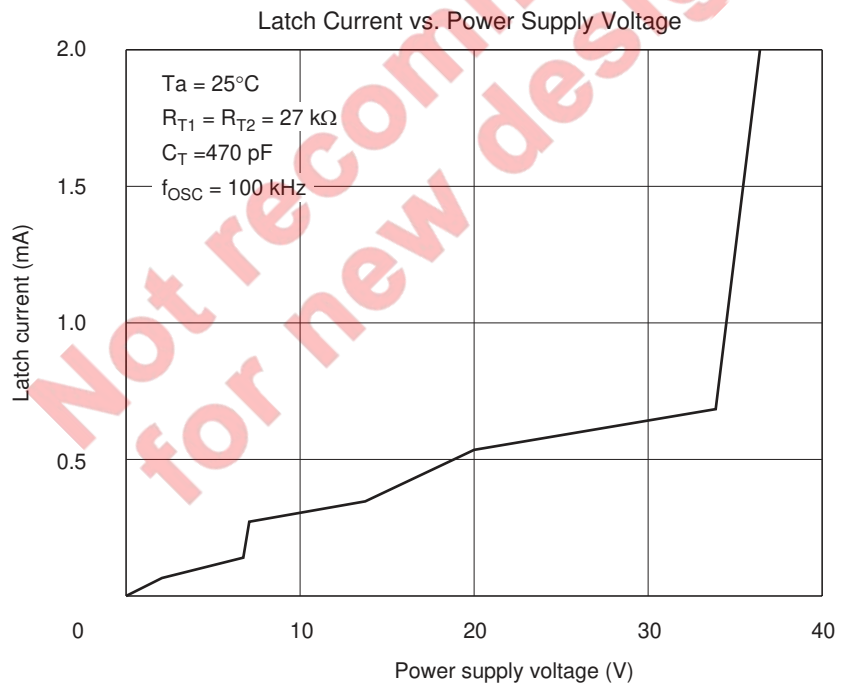
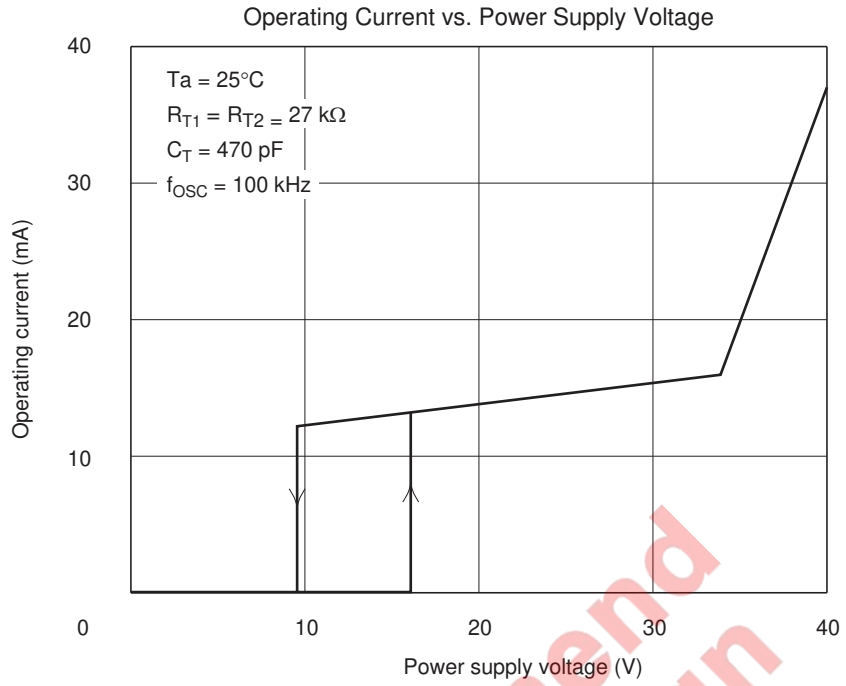
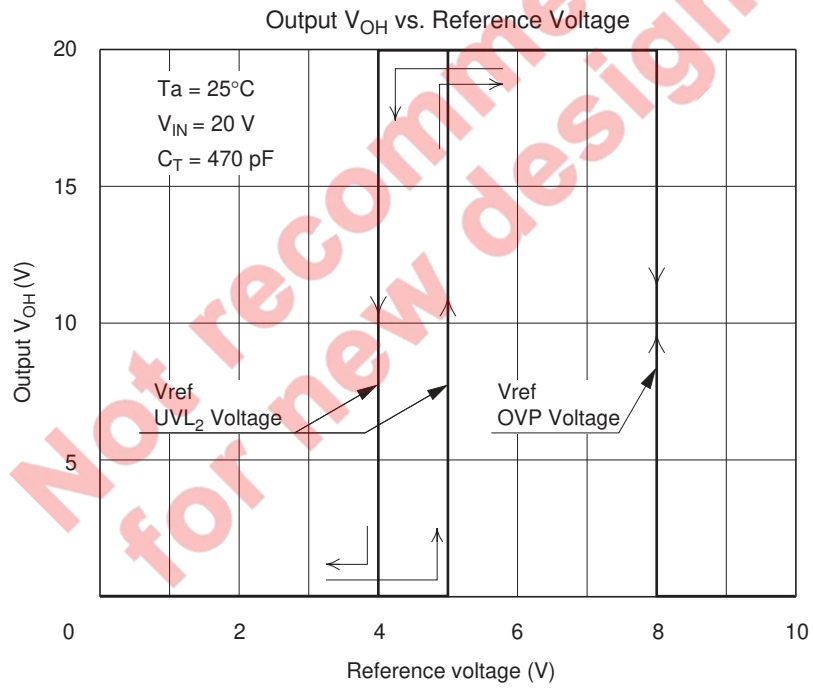
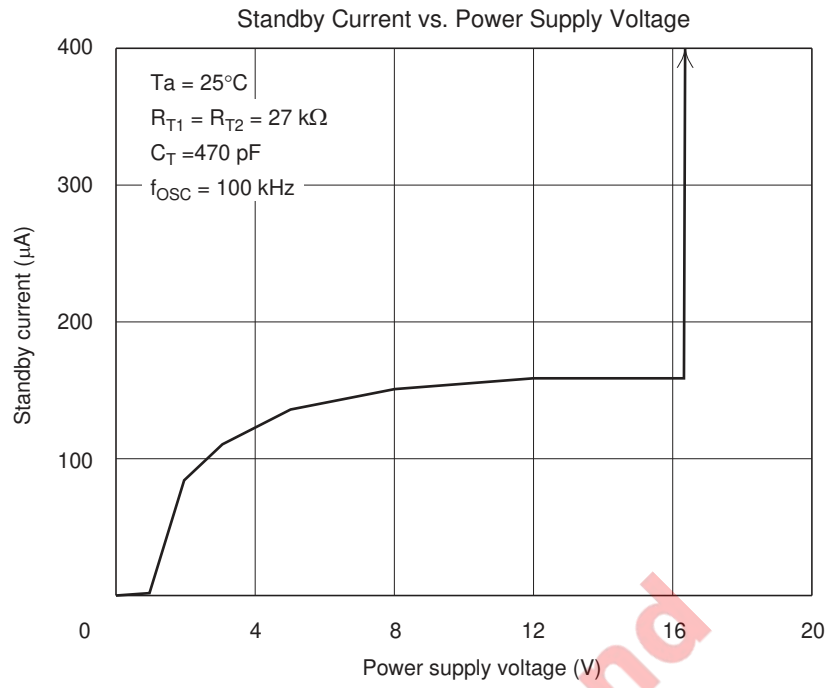
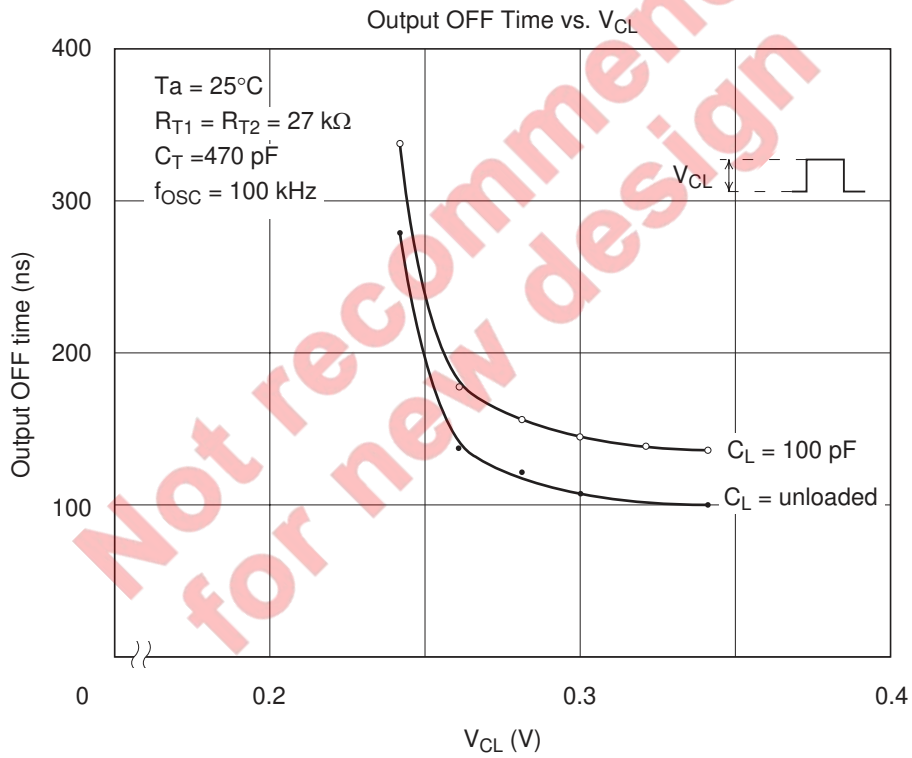
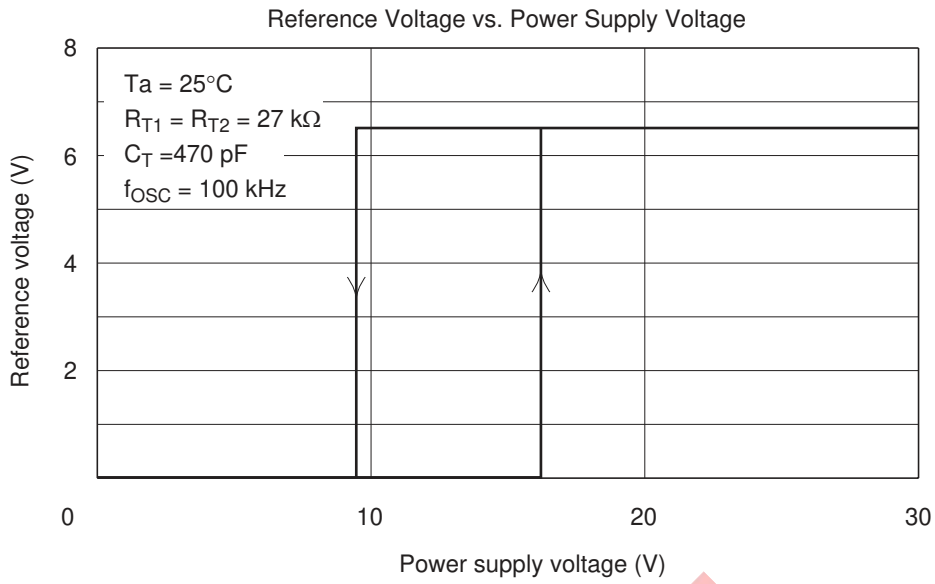

Figure 3 Sample Remedial Circuit

Characteristic Curves







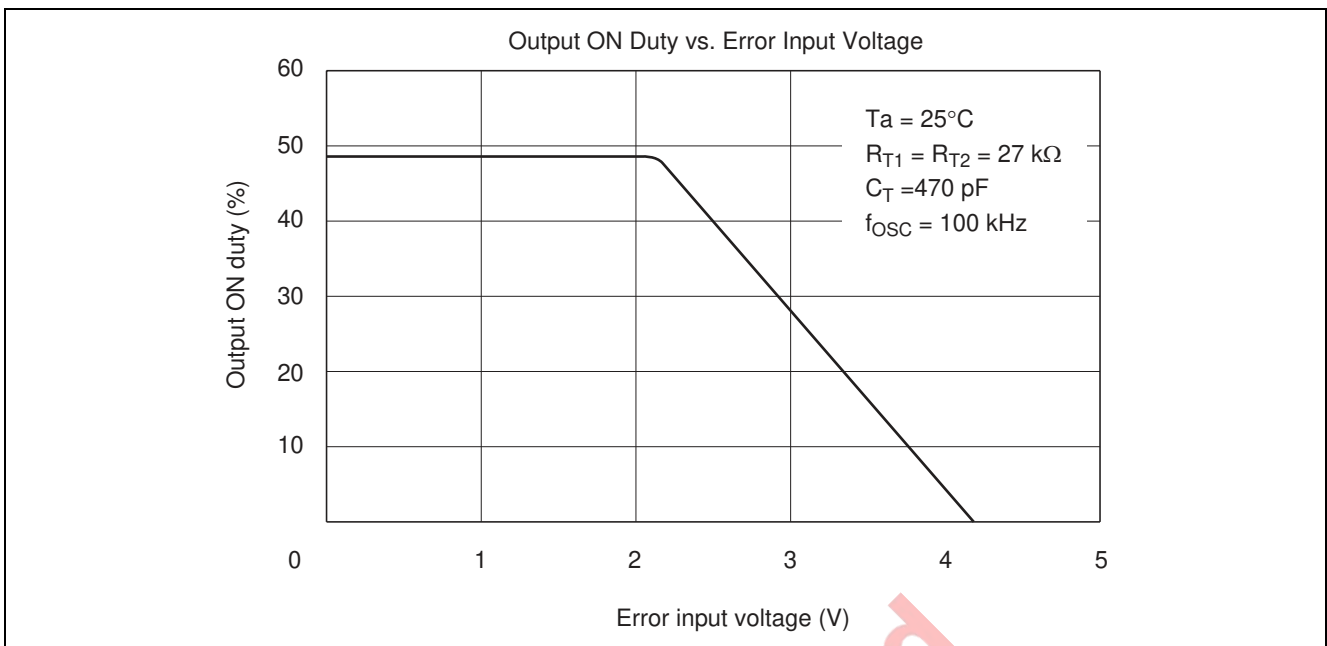

Not recommend
for new design

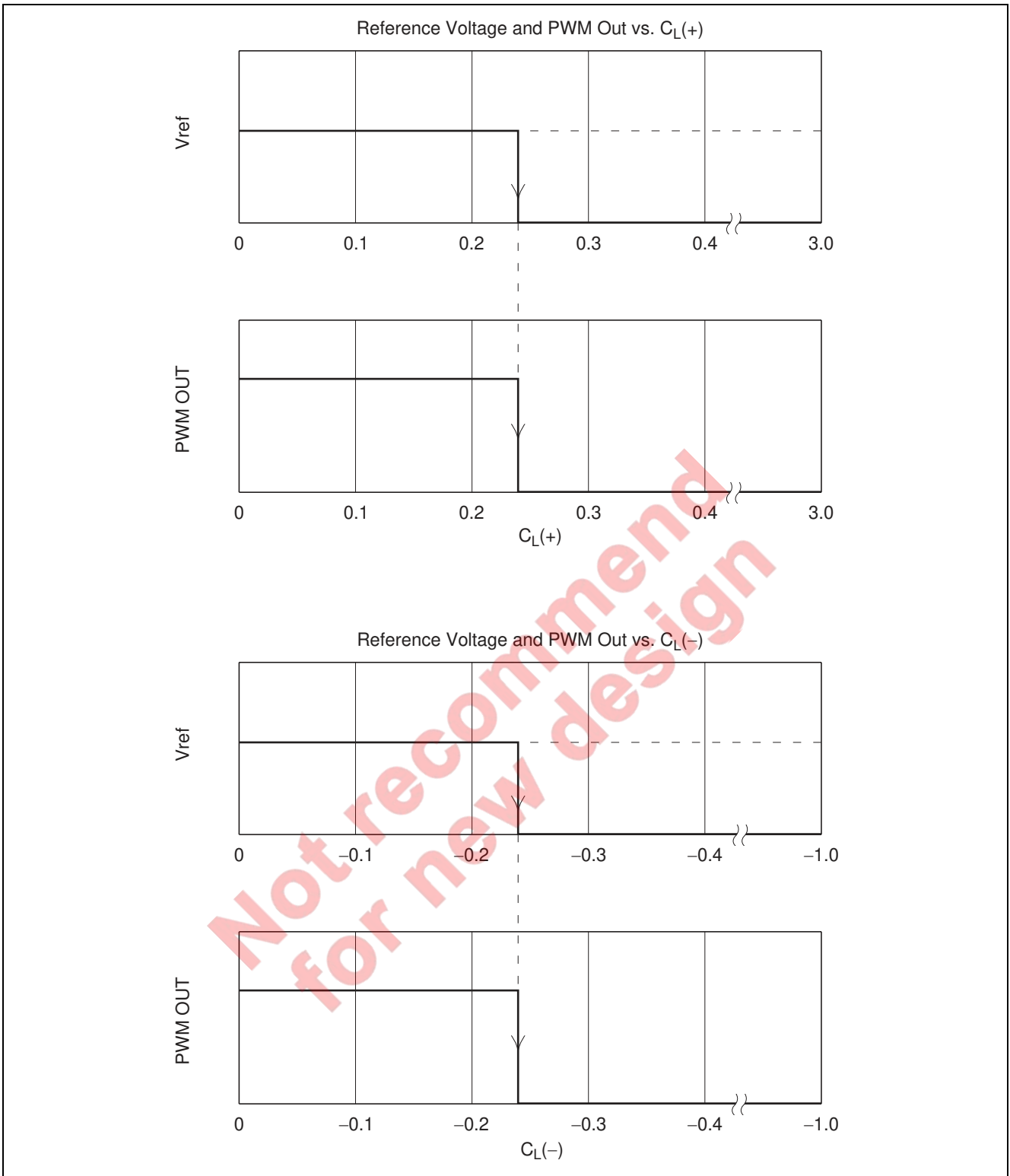

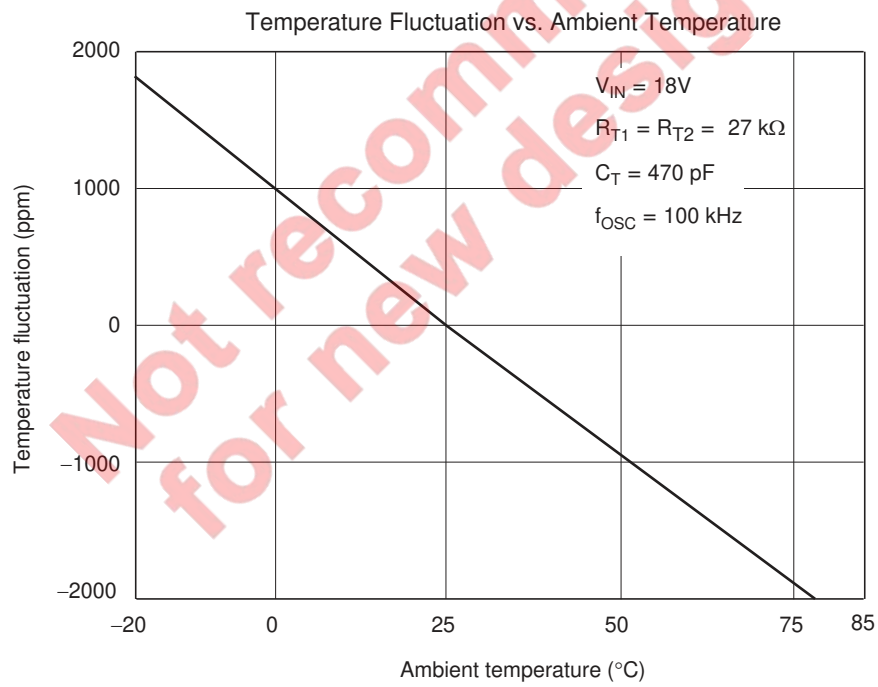
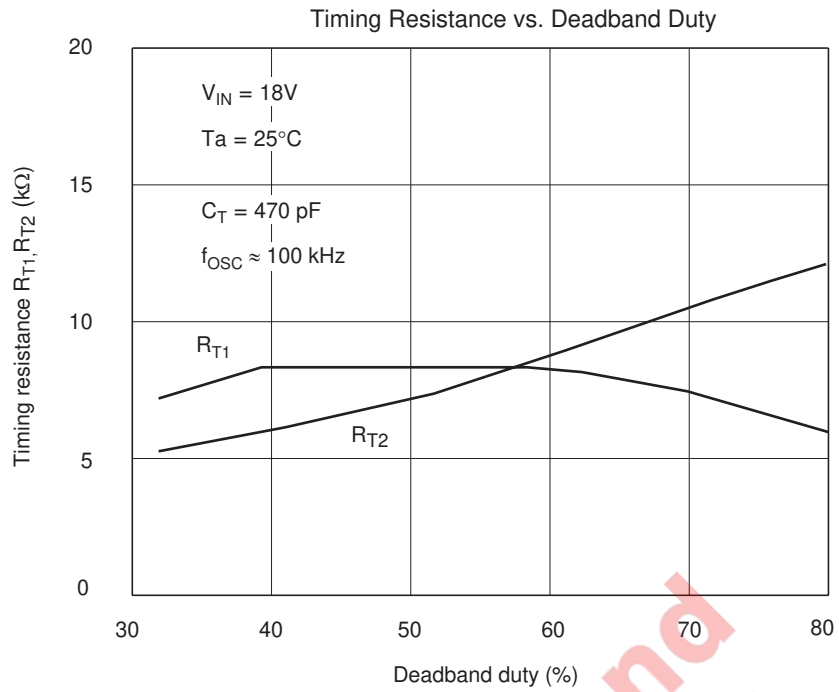

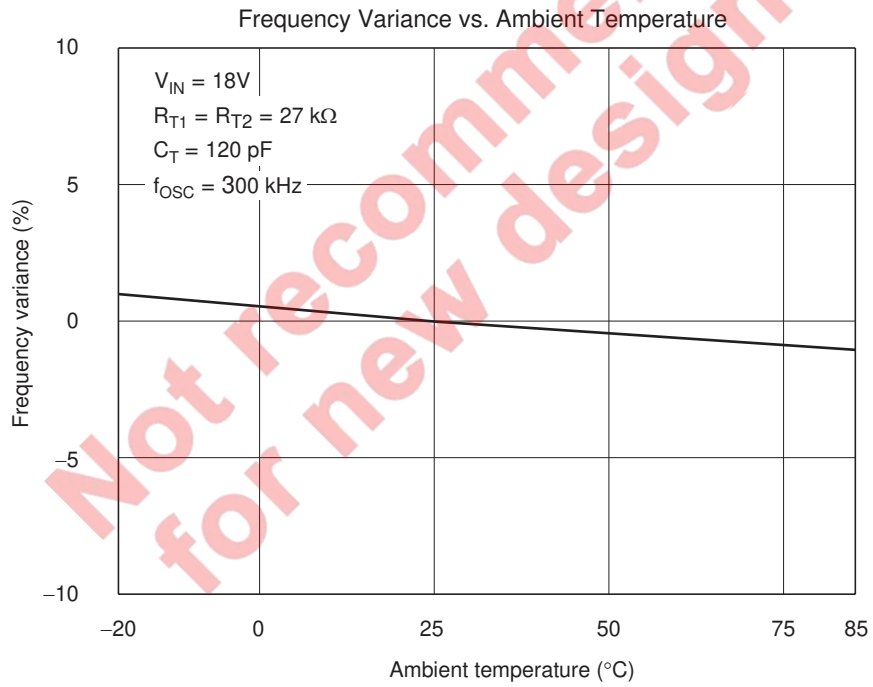
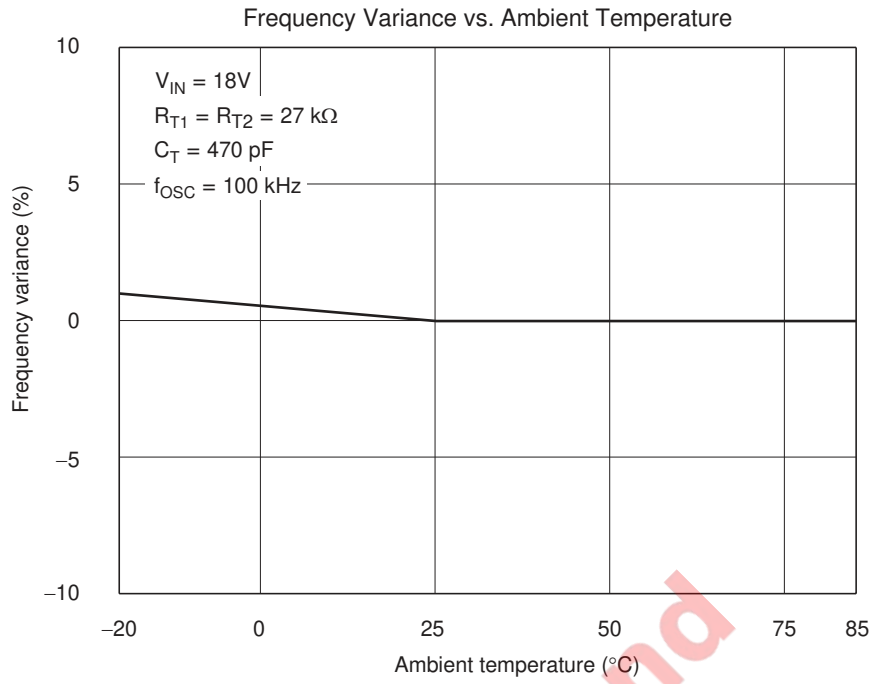

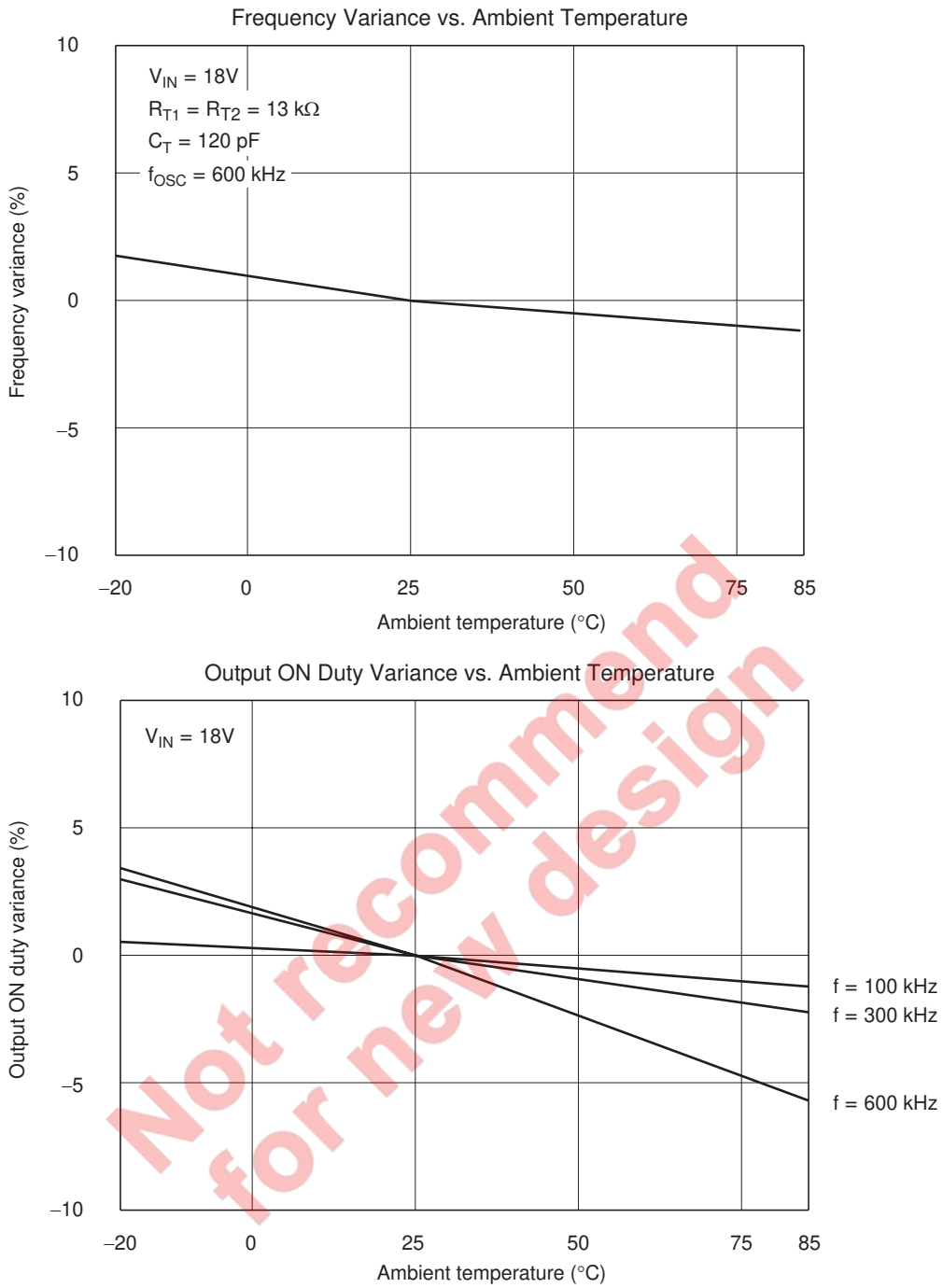

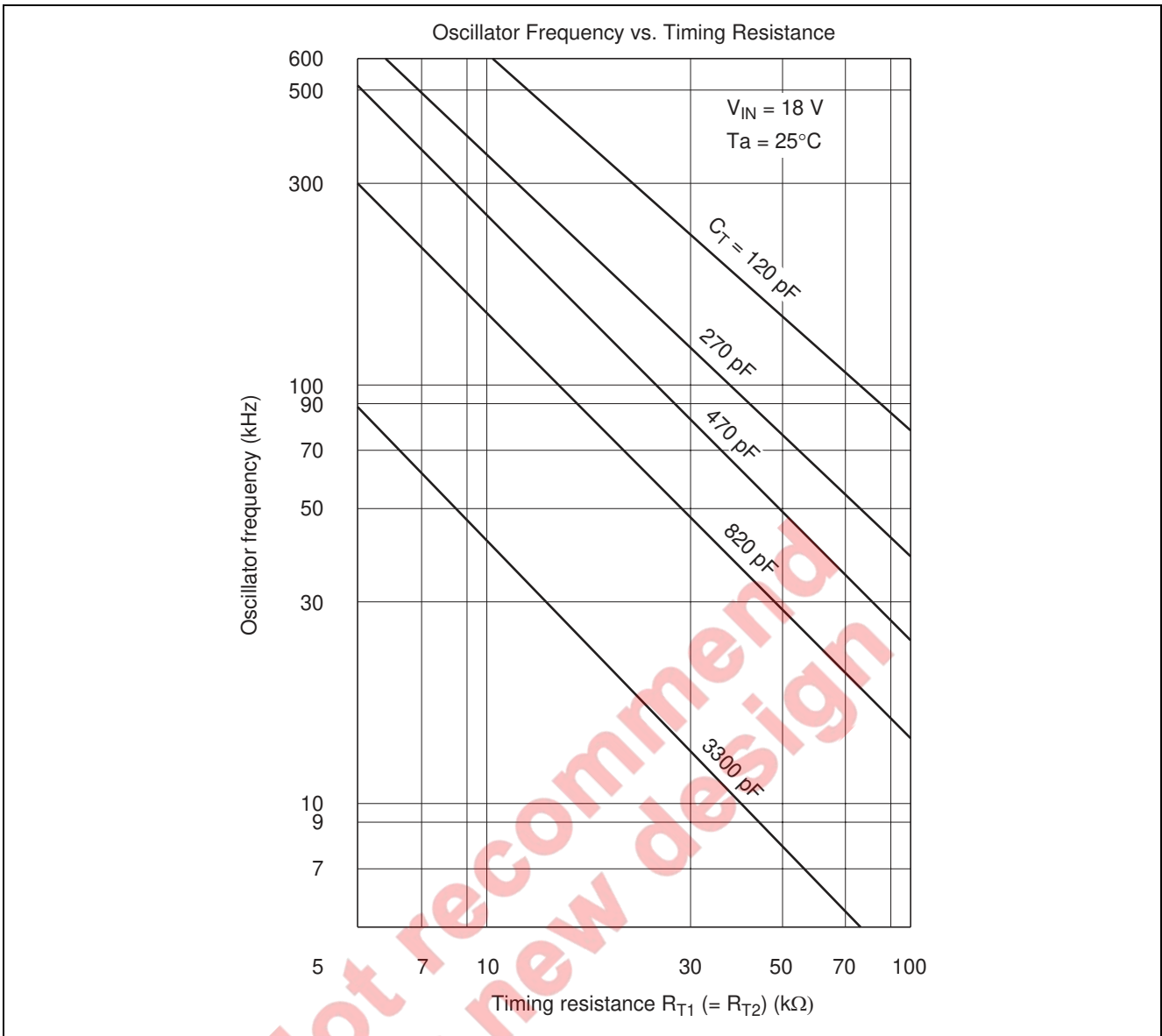

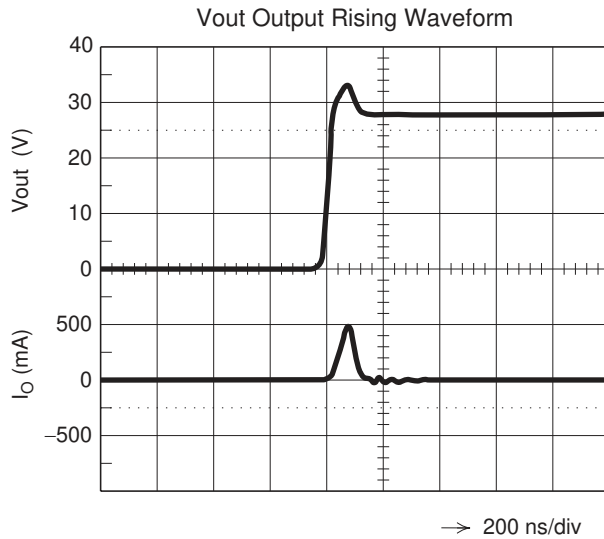

Test circuit

$T_a = 25^\circ\text{C}$
 $R_{T1} = R_{T2} = 27\text{ k}\Omega$
 $C_T = 470\text{ pF}$
 $f_{\text{OSC}} = 100\text{ kHz}$

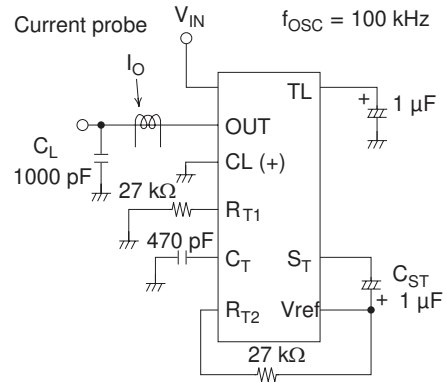

* Current probe: Tektronix AM503

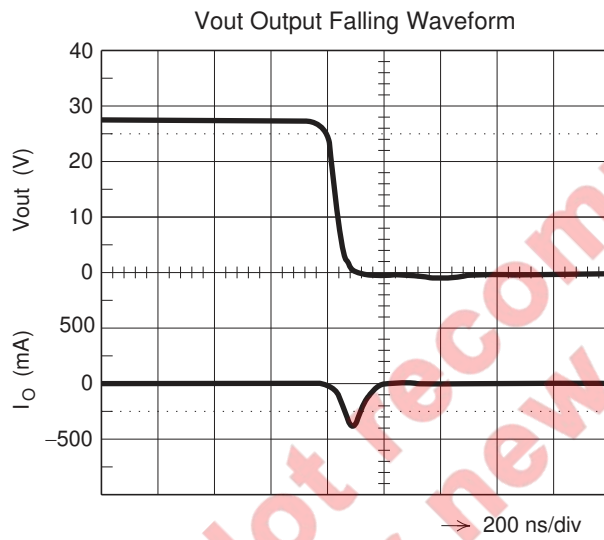

Not recommended for new design

Operating waveform at the TL pin

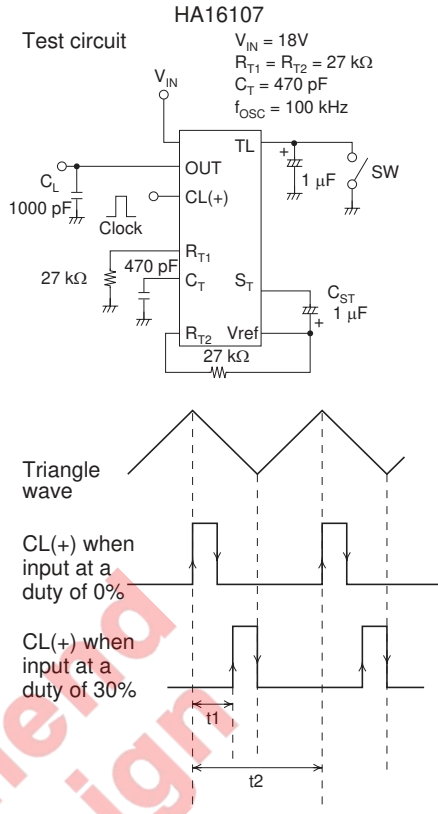
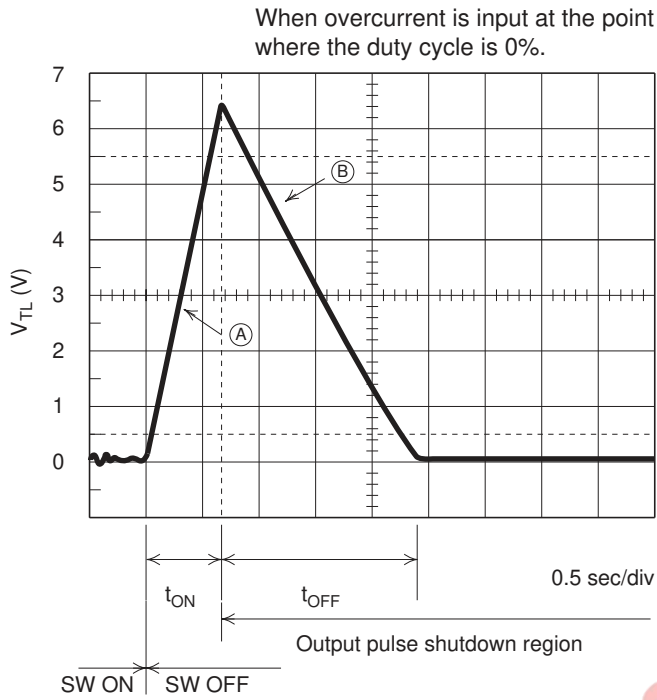

$$Du = \frac{t_1}{t_2} \times 100 (\%)$$

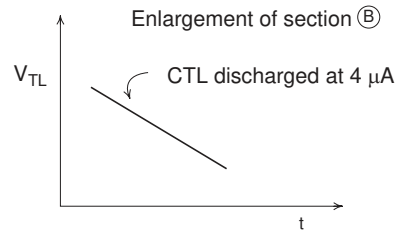
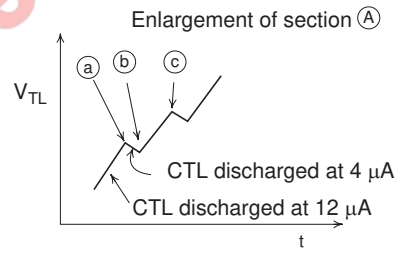
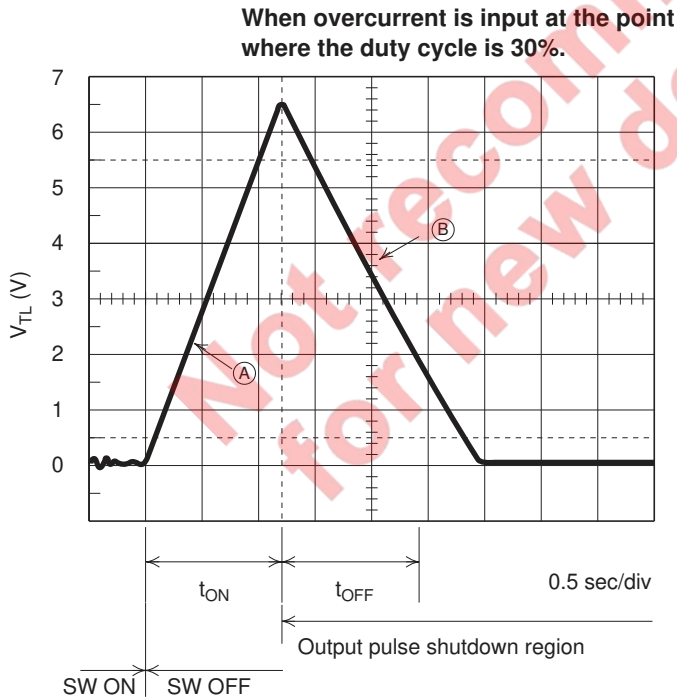

- ① to ② : PWM pulse output is High
- ② : The point where overcurrent is detected
- ② to ③ : PWM pulse output is Low.

Operating waveform at the ON/OFF pin

When overcurrent is input at the point where the duty cycle is 0%.

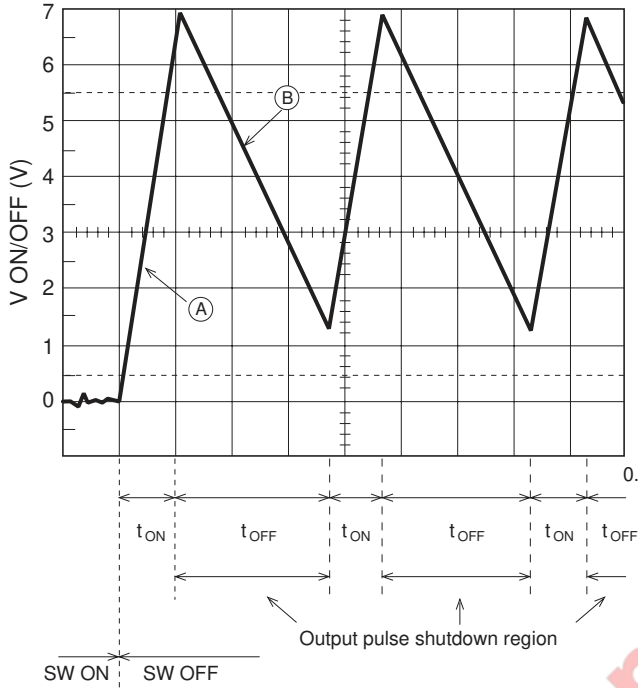

HA16108
 Test circuit
 $V_{IN} = 18V$
 $R_{T1} = R_{T2} = 27\text{ k}\frac{1}{2}$
 $C_T = 470\text{ pF}$
 $f_{OSC} = 100\text{ kHz}$

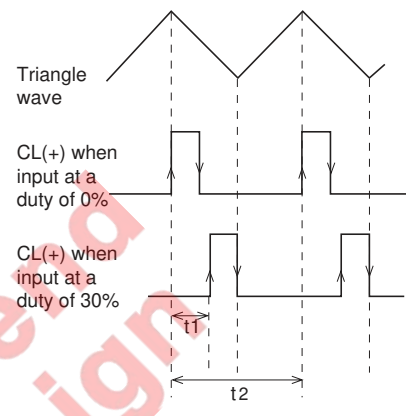
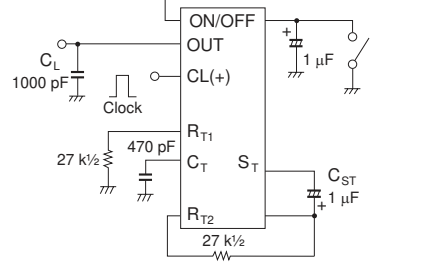

$$Du = \frac{t1}{t2} \times 100 (\%)$$

When overcurrent is input at the point where the duty cycle is 30%.

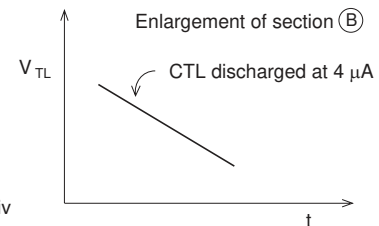
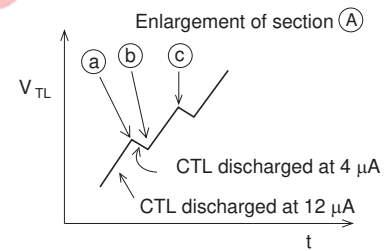
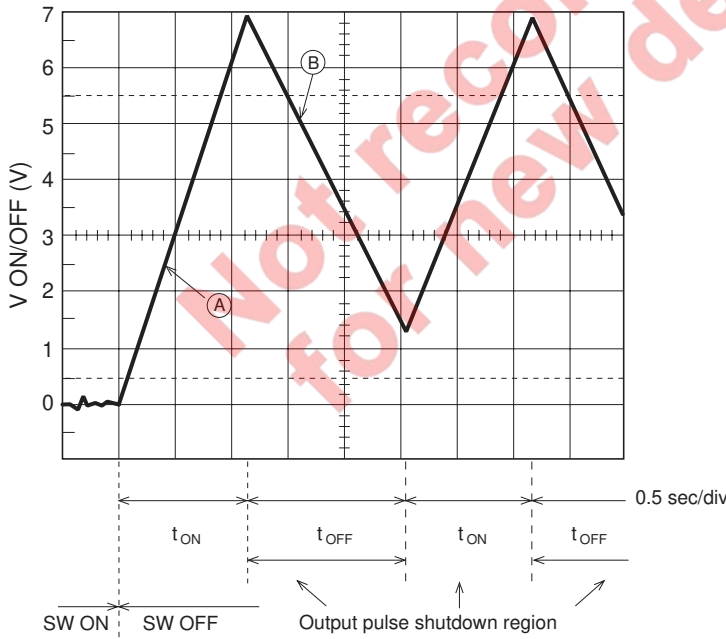

- ① a to ② b : PWM pulse output is High.
- ② b : The point where overcurrent is detected.
- ② b to ③ c : PWM pulse output is Low.

Error Amplifier Characteristic

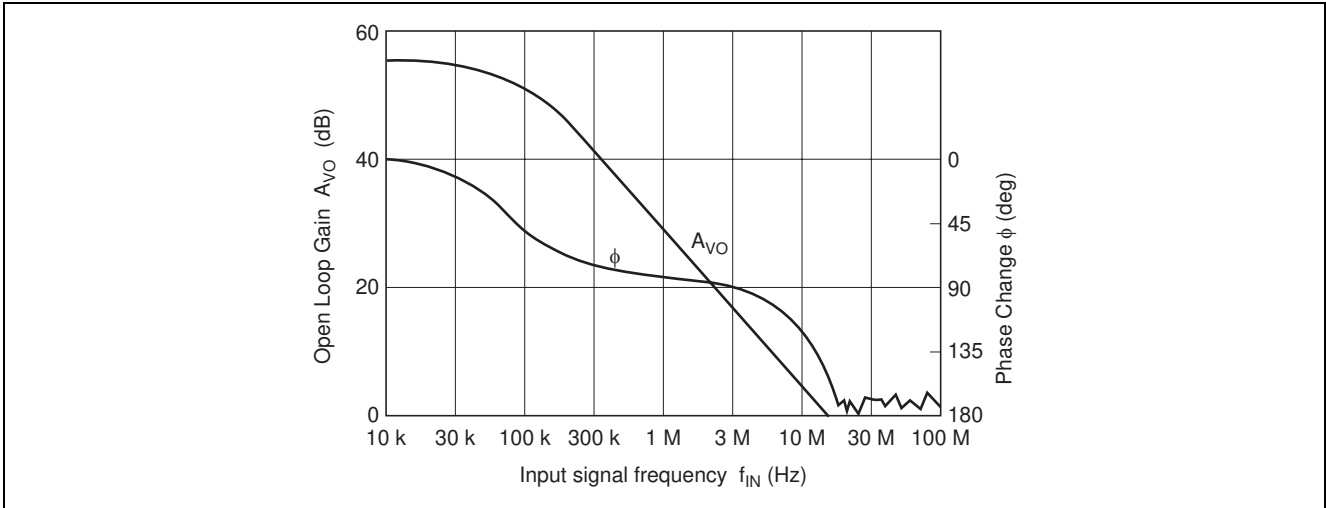

Examples of Drooping Characteristics of Power Supplies Using these Ics

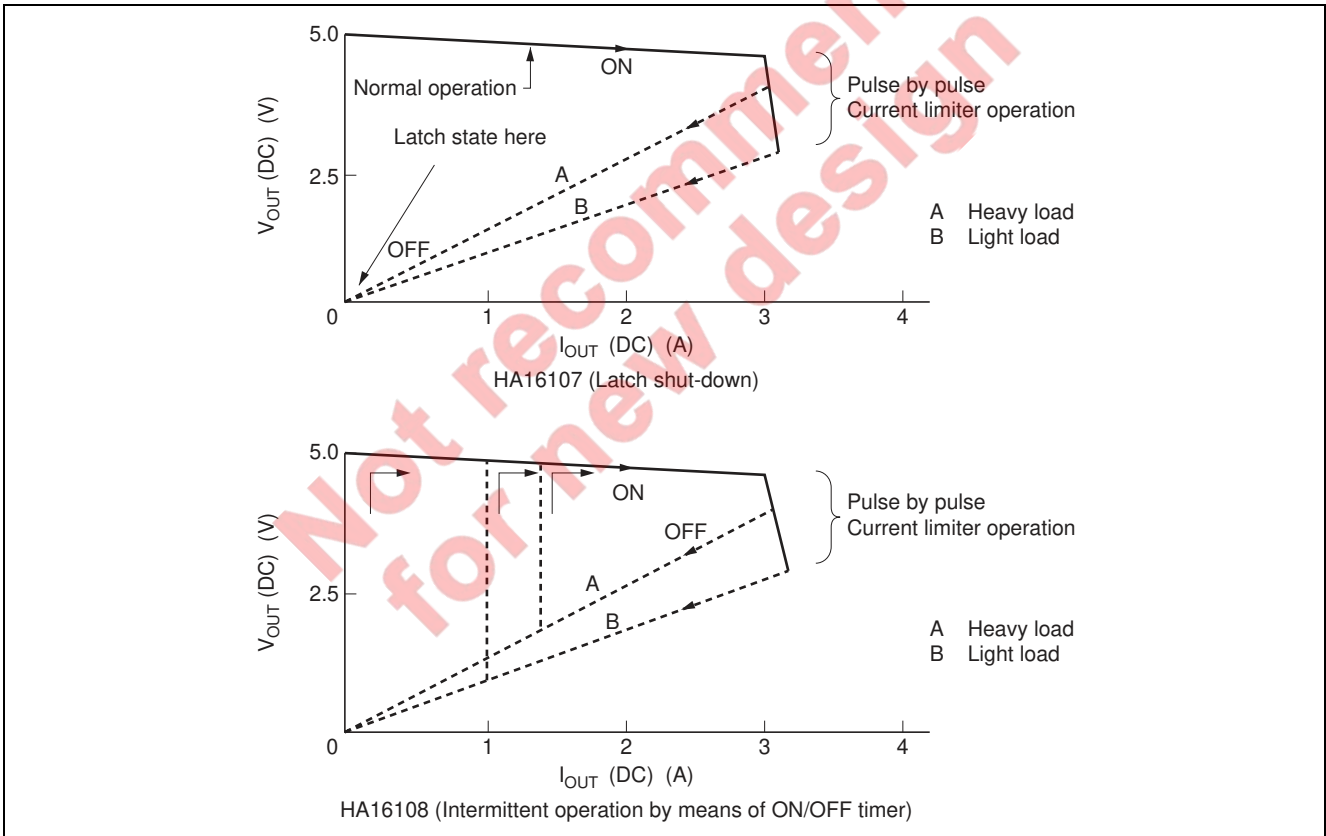

Operating Circuit Example

- Flyback Transformer Application Example
(IC Vref used as system as reference voltage)

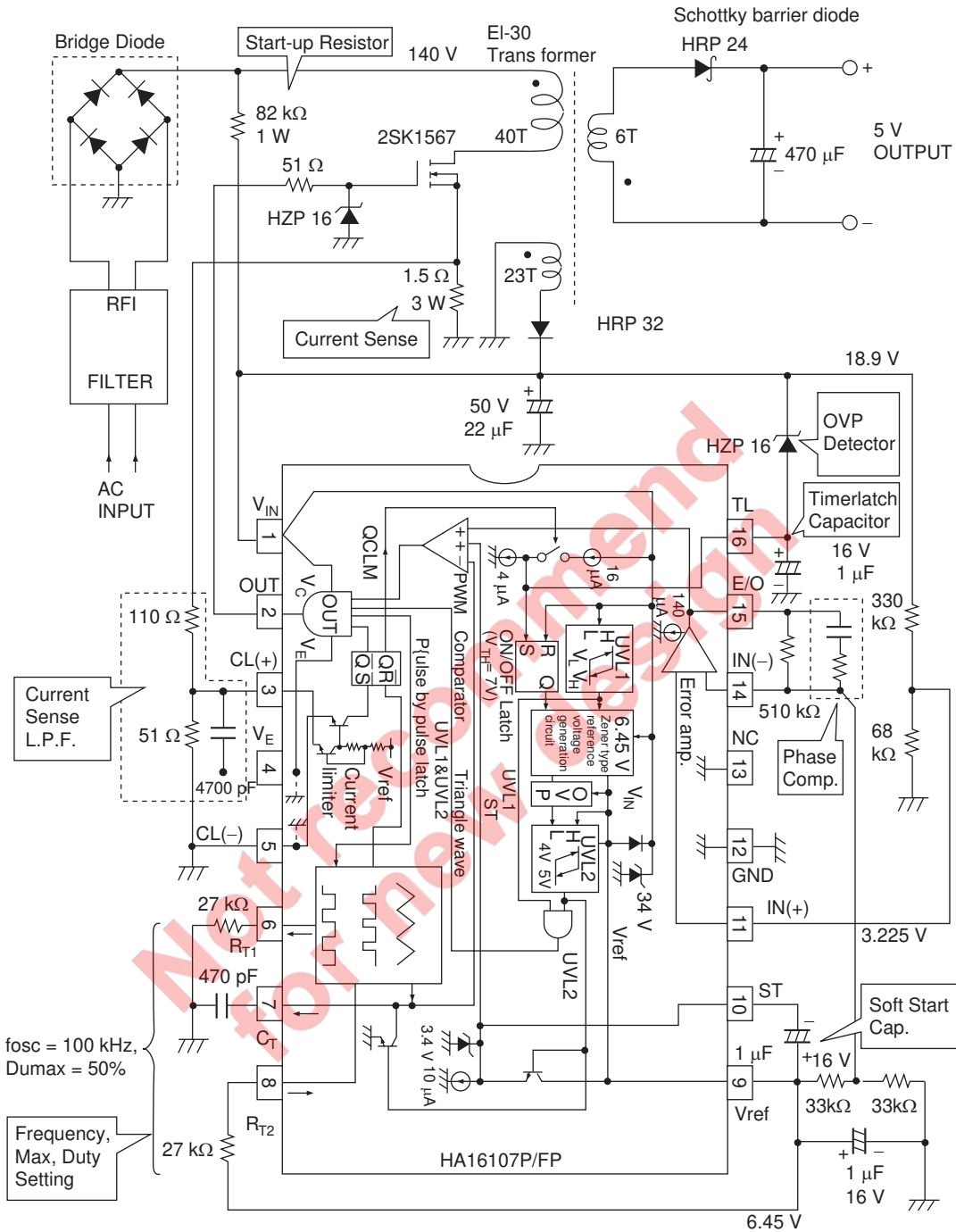

- When OVP signal is inserted at CL(+) pin

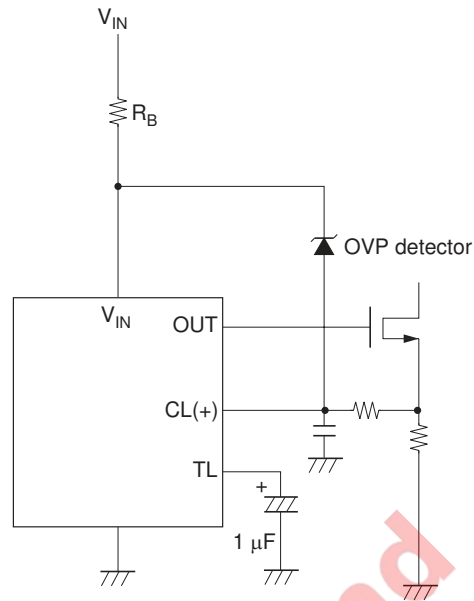

When the OVP detection Zener diode turns on, latch shutdown of the output is performed after the elapse of the time determined by the capacitance connected the TL pin.

Not recommended
for new designs

Application

1. Use of Error Amplifier for Flyback Transformer Primary-Side Control

In this example, the fact that the transformers winding ratio and voltage ratio in Figure 4 are mutually proportional is made use of in a flyback transformer type AC-DC converter. As fluctuation of output voltage V_2 also appears in IC power supply voltage V_3 , this is divided by a resistance and amplified by an error amplifier. An advantage of this method is that a photocoupler need not be used, making it possible to configure a power supply with a small number of parts (this example cannot be applied to a forward transformer).

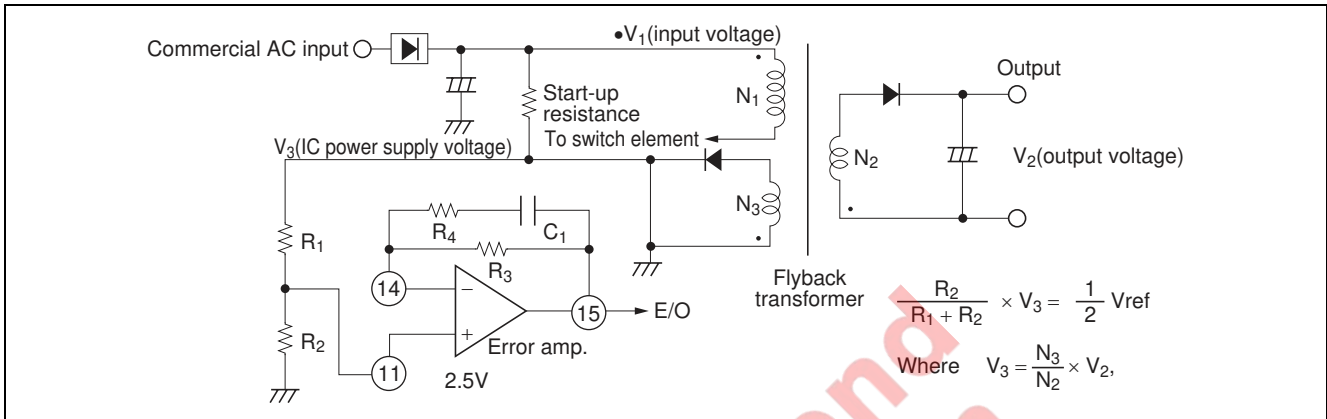

Figure 4 Error Amplifier Peripheral Circuitry Diagram

<Determining External Constants around Error Amplifier>

1. Determining DC Characteristics

In Figure 4, the relational expression in the box is satisfied, and therefore parameters are determined based on this. The absolute value of the number of transformer windings is determined based on the equation $N_1:N_2:N_3 = V_1:V_2:V_3$, taking primary inductance into consideration.

Next, IC operating voltage V_3 is made around 11V to 18V, taking the UVL voltage into consideration. If V_3 is too large, the power consumption of the IC will increase, causing heat emission problems. If V_3 is too small, on the other hand, there will be problems with defective power supply start-up.

2. Determining Error Amplifier Gain vs. Frequency Characteristic

Taking the configuration in Figure 4, the error amplifier gain characteristic with respect to fluctuation of output voltage V_2 is as shown in Figure 5.

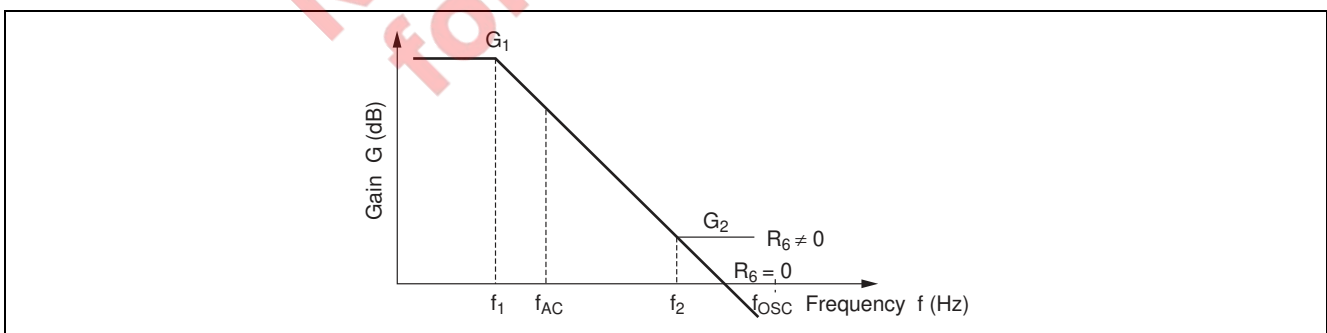

Figure 5 Error Amplifier Characteristic

In Figure 5, the parameters are given by the following equations.

Gain

$$G_1 = V_3/V_2 \times R_3/R_1$$

$$G_2 = V_3/V_2 \times R_4/R_1$$

Corner frequencies

$$f_1 = 1/(2\pi C_1 R_3)$$

$$f_2 = 1/(2\pi C_1 R_4)$$

Where $R_3 \gg R_4$ (10:1 or above)

G_1 is made around 30 to 50 dB, taking both regulation and stability into consideration.

f_1 is made a lower value than commercial frequency ripple f_{AC} , thus preventing hunting (a system instability phenomenon).

Next, G_2 is set to 0 dB or less as a guideline, so that there is no gain in IC operating frequency f_{OSC} (several tens to several hundreds of kHz). f_2 should be set to a value that is substantially smaller than f_{OSC} , and that is appropriate for the power supply response speed (several kHz). In the case of a bridge type rectification circuit, the commercial frequency ripple is twice the input frequency (with a 50 Hz commercial frequency, $f_{AC} = 100$ Hz).

2. External Constant Design for Current Detection Section (HA16107, HA16108, HA16666)

In the above IC models, which incorporate a current detection function, a low-pass filter such as shown in Figure 6 must be inserted between switch element current detection resistance R_{CS} and the current detection pin of the IC.

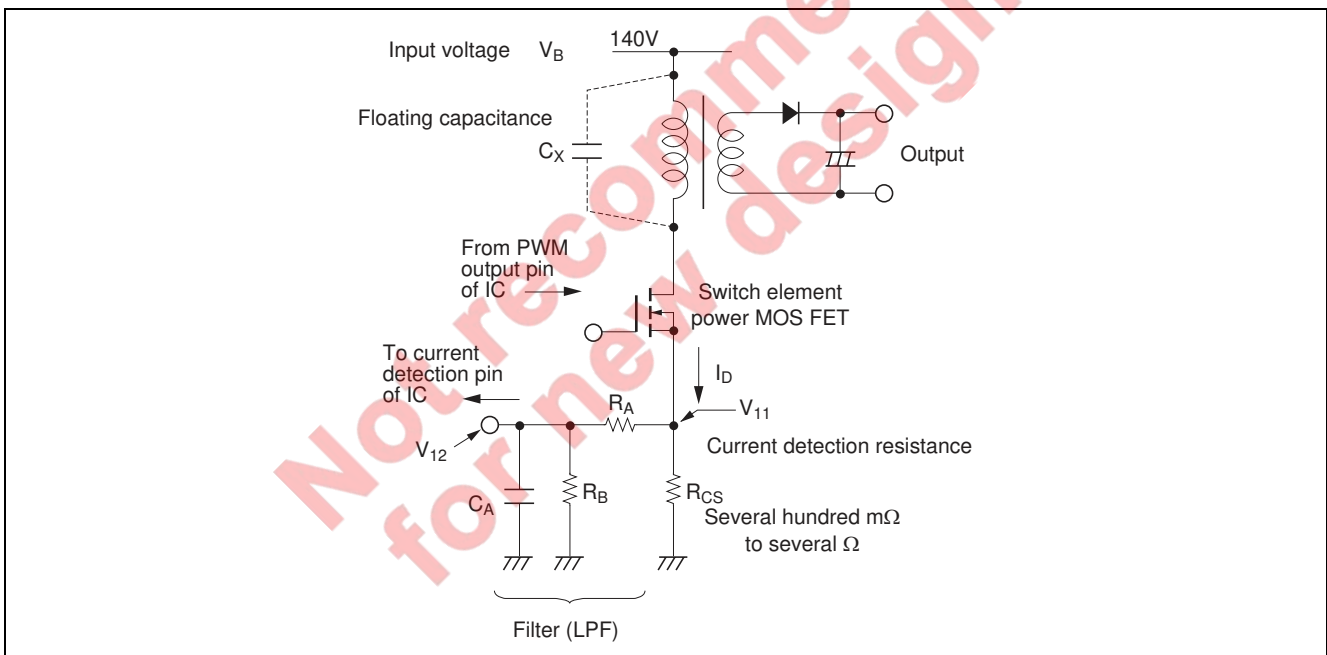

Figure 6 Current Detection Circuit

The reason for this is that, when the switch element is on in each cycle, there is an impulse current associated with charging of transformer floating capacitance C_X , and IC current detection malfunctions (see Figure 7).

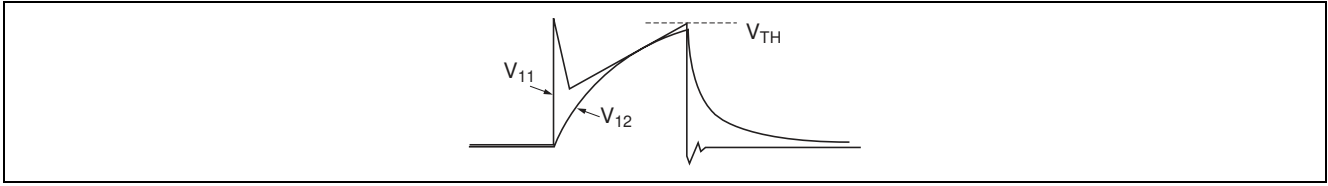

Figure 7 Current Detection Waveform

<Setting Numeric Values>

If the switch element current to be detected is designated I_D , and the current detection resistance R_{CS} , then the following equation is satisfied using the parameters in Figure 6.

$$I_D \times R_{CS} = ((R_A + R_B)/R_B) V_{TH}$$

V_{TH} is the detection level voltage of the IC (240 mV in the case of the HA16107, for example). R_A and R_B are set to values on the order of several hundred Ω to several $k\Omega$, so that R_{CS} is not affected.

Next, the filter cutoff frequency is set according to the following equation.

$$f_C = 1/(2\pi C_A (R_A/R_B))$$

f_C can be found with the following guideline, using IC operating frequency f_{OSC} , power supply rating on-duty D , and power MOS element turn-on time t_{ON} .

$$f_{OSC}/D \leq f_C \leq 1/(100 \times t_{ON})$$

Value 100 in the above equation provides a margin for noise, ringing, and so forth.

<Actual Example>

In an SW power supply using an HA16107, with a 100 kHz operating frequency and a D value of 30%, the relevant values were as follows: $V_B = 140$ V, $C_X = 80$ pF, $t_{ON} = 10$ ns. Thus, when $R_{CS} = 1$ Ω , the V_{11} level peak value reaches the following figure.

$$\begin{aligned} V_{11} \text{ (peak)} &= R_{CS} \times I_D \text{ peak} \\ &= R_{CS} \times (V_B \times C_X)/t_{ON} \\ &= 1\Omega \times (140 \text{ V} \times 80 \text{ pF})/10 \text{ ns} \\ &= 1.12 \text{ (V)} \end{aligned}$$

A filter with the following constants was then inserted.

$$R_A = R_B = 1 \text{ k}\Omega, C_A = 1000 \text{ pF}$$

At this time, the detectable drain current is 0.48 (A), and the filter cutoff frequency is 318 (kHz). Note that increasing a filter time constant is effective against noise, but if the value is too large, error will arise in the switch element current detection level.

3. IC Heat Emission Problem and Countermeasures (HA16107 Series, HA16114 Series)

While the above ICs can directly drive a power MOS FET gate, if the method of use is not thoroughly investigated, there will be a tendency for the gate drive power to increase and a problem of heat emission by the IC may occur. This section should therefore be noted and appropriate measures taken to prevent this kind of problem.

1. Power MOS FET Drive Characteristics

When power MOS FET drive is performed, in order to lower the on-resistance sufficiently, overdrive is normally performed with a voltage considerably higher than 5 V, for example, such as the 15 V power supply voltage of the IC.

At this time, the power that should be supplied from the IC to the power MOS FET is determined by gate load Q_g in Figure 9.

2. IC Heat-Emission Power Calculation (Figure 9)

The power that contributes to IC heat emission is calculated by means of the following equation.

$$P_d = V_{IN} I_Q + 2Q_g V_{IN} f$$

Where V_{IN} : Power supply voltage of IC
 I_Q : Operating current of IC (unloaded)
 Q_g : Above-mentioned gate load
 f : Operating frequency of IC

The coefficient, 2, indicates that gate discharging also contributes to heat emission.

4. Power MOS FET Gate Resistance Design (HA16107 Series, HA16114 Series)

There are the following three purposes in connecting a gate resistance, and the circuit is generally of the kind shown in Figure 8.

- (1) To suppress peak current due to gate charging
- (2) To protect IC output pins
- (3) To provide drive appropriate to power MOS FET input characteristics

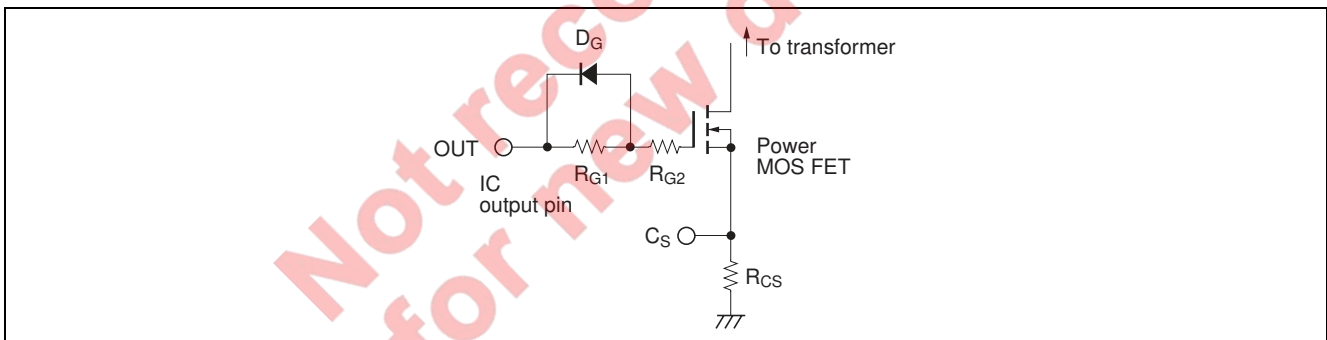

Figure 8 Gate Drive Circuit

This gate resistance R_G is given by the following equation.

$$R_G = (V_G/I_G) - (V_G \times t_{ON})/Q_g, \quad R_G = R_{G1} + R_{G2}$$

I_G : Gate input peak current

V_G : Gate drive voltage wave high value (equal to power supply voltage of IC)

t_{ON} : Power MOS FET turn-on time

t_{OFF} : Power MOS FET turn-off time

Q_g : Gate charge according to Figure 9

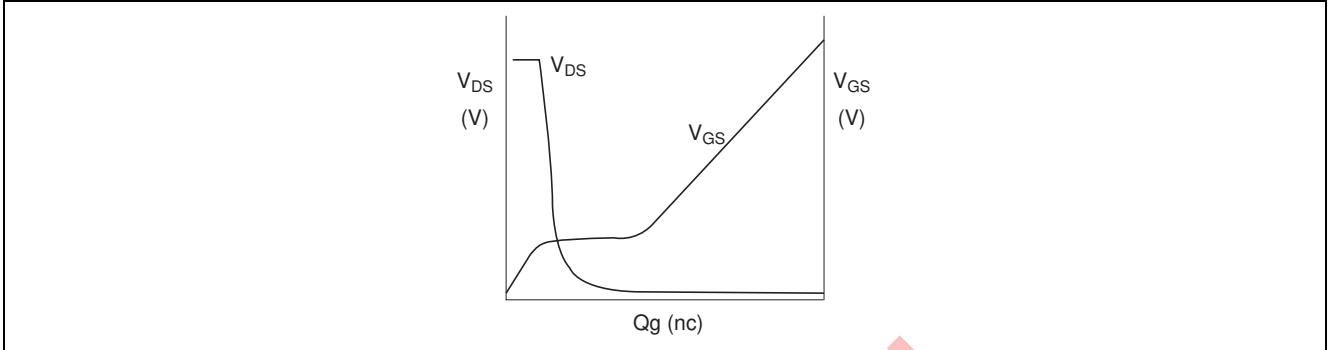

Figure 9 Power MOS FET Dynamic Input Characteristics

Refer to the power MOS FET catalog for information on t_{ON} and Q_g .

By dividing R_G into R_{G1} and R_{G2} , it is possible for speed to be slowed when the power MOS FET is on, and increased when off.

Power MOS FET on and off times when mounted, t_{ON}' and t_{OFF}' , are as follows.

$$t_{ON}' = t_{ON} + Q_g(R_{G1} + R_{G2})/V_G$$

$$t_{OFF}' = t_{OFF} + Q_g \cdot R_{G2}/V_G$$

<Actual Example>

When driving a power MOS FET and 2SK1567 with an HA16107, etc.

($R_{G1} = 100 \Omega$, $R_{G2} = 20 \Omega$, $V_G = 15 \text{ V}$)

$$t_{ON}' = 70 \text{ ns} + 36 \text{ nc} \cdot (100 \Omega + 20 \Omega)/(15 \text{ V}) = 360 \text{ (ns)}$$

$$t_{OFF}' = 135 \text{ ns} + 36 \text{ nc} \cdot (20 \Omega)/(15 \text{ V}) = 183 \text{ (ns)}$$

Generally, the gate resistance values in the case of this circuit configuration are on the order of 100 to 470 Ω for R_{G1} and 10 to 47 Ω for R_{G2} .

Package Dimensions

As of January, 2003
Unit: mm

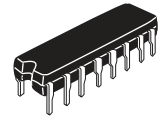
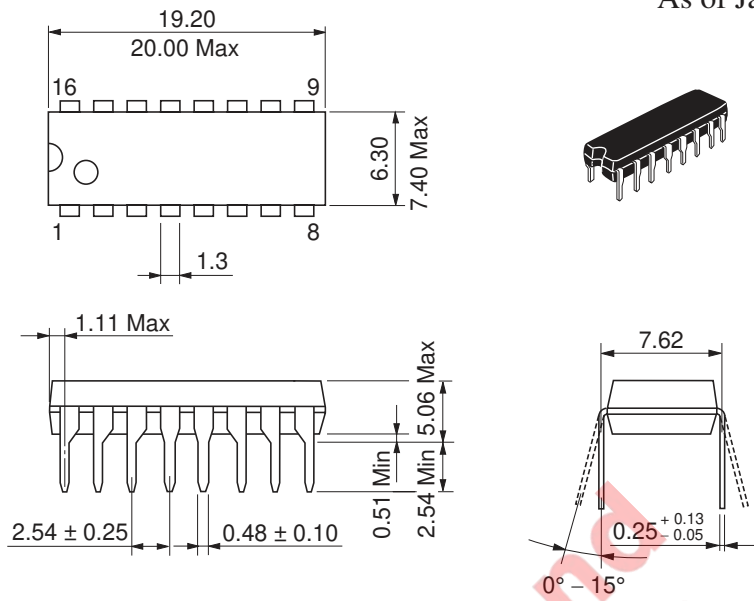

| | |
|------------------------|----------|
| Package Code | DP-16 |
| JEDEC | Conforms |
| JEITA | Conforms |
| Mass (reference value) | 1.07 g |

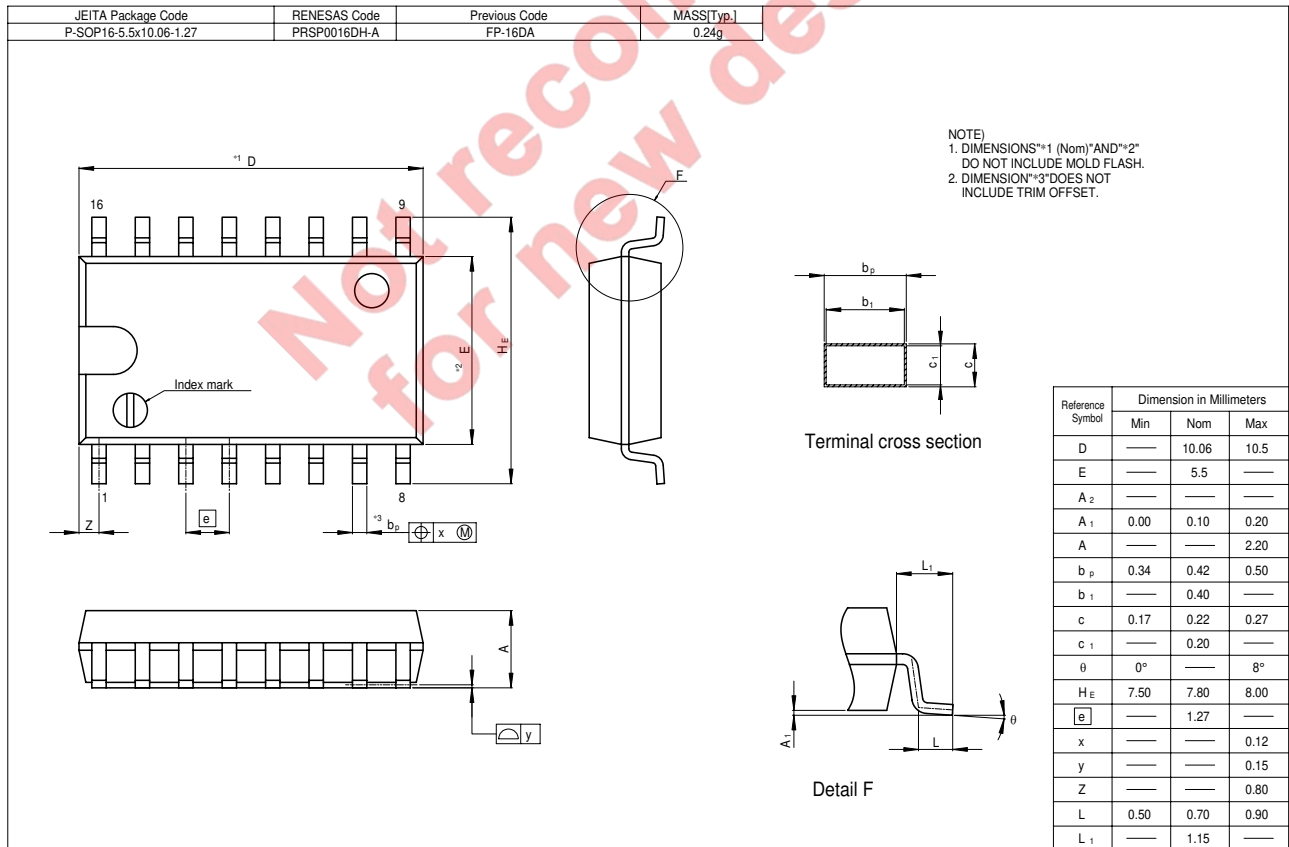

Renesas Technology Corp. Sales Strategic Planning Div. Nippon Bldg., 2-6-2, Ohte-machi, Chiyoda-ku, Tokyo 100-0004, Japan

Keep safety first in your circuit designs!

1. Renesas Technology Corp. puts the maximum effort into making semiconductor products better and more reliable, but there is always the possibility that trouble may occur with them. Trouble with semiconductors may lead to personal injury, fire or property damage.
Remember to give due consideration to safety when making your circuit designs, with appropriate measures such as (i) placement of substitutive, auxiliary circuits, (ii) use of nonflammable material or (iii) prevention against any malfunction or mishap.

Notes regarding these materials

1. These materials are intended as a reference to assist our customers in the selection of the Renesas Technology Corp. product best suited to the customer's application; they do not convey any license under any intellectual property rights, or any other rights, belonging to Renesas Technology Corp. or a third party.
2. Renesas Technology Corp. assumes no responsibility for any damage, or infringement of any third-party's rights, originating in the use of any product data, diagrams, charts, programs, algorithms, or circuit application examples contained in these materials.
3. All information contained in these materials, including product data, diagrams, charts, programs and algorithms represents information on products at the time of publication of these materials, and are subject to change by Renesas Technology Corp. without notice due to product improvements or other reasons. It is therefore recommended that customers contact Renesas Technology Corp. or an authorized Renesas Technology Corp. product distributor for the latest product information before purchasing a product listed herein.
The information described here may contain technical inaccuracies or typographical errors.
Renesas Technology Corp. assumes no responsibility for any damage, liability, or other loss rising from these inaccuracies or errors.
Please also pay attention to information published by Renesas Technology Corp. by various means, including the Renesas Technology Corp. Semiconductor home page (<http://www.renesas.com>).
4. When using any or all of the information contained in these materials, including product data, diagrams, charts, programs, and algorithms, please be sure to evaluate all information as a total system before making a final decision on the applicability of the information and products. Renesas Technology Corp. assumes no responsibility for any damage, liability or other loss resulting from the information contained herein.
5. Renesas Technology Corp. semiconductors are not designed or manufactured for use in a device or system that is used under circumstances in which human life is potentially at stake. Please contact Renesas Technology Corp. or an authorized Renesas Technology Corp. product distributor when considering the use of a product contained herein for any specific purposes, such as apparatus or systems for transportation, vehicular, medical, aerospace, nuclear, or undersea repeater use.
6. The prior written approval of Renesas Technology Corp. is necessary to reprint or reproduce in whole or in part these materials.
7. If these products or technologies are subject to the Japanese export control restrictions, they must be exported under a license from the Japanese government and cannot be imported into a country other than the approved destination.
Any diversion or reexport contrary to the export control laws and regulations of Japan and/or the country of destination is prohibited.
8. Please contact Renesas Technology Corp. for further details on these materials or the products contained therein.



RENESAS SALES OFFICES

<http://www.renesas.com>

Refer to "<http://www.renesas.com/en/network>" for the latest and detailed information.

Renesas Technology America, Inc.
450 Holger Way, San Jose, CA 95134-1368, U.S.A
Tel: <1> (408) 382-7500, Fax: <1> (408) 382-7501

Renesas Technology Europe Limited
Dukes Meadow, Millboard Road, Bourne End, Buckinghamshire, SL8 5FH, U.K.
Tel: <44> (1628) 585-100, Fax: <44> (1628) 585-900

Renesas Technology Hong Kong Ltd.
7th Floor, North Tower, World Finance Centre, Harbour City, 1 Canton Road, Tsimshatsui, Kowloon, Hong Kong
Tel: <852> 2265-6688, Fax: <852> 2730-6071

Renesas Technology Taiwan Co., Ltd.
10th Floor, No.99, Fushing North Road, Taipei, Taiwan
Tel: <886> (2) 2715-2888, Fax: <886> (2) 2713-2999

Renesas Technology (Shanghai) Co., Ltd.
Unit2607 Ruijing Building, No.205 Maoming Road (S), Shanghai 200020, China
Tel: <86> (21) 6472-1001, Fax: <86> (21) 6415-2952

Renesas Technology Singapore Pte. Ltd.
1 Harbour Front Avenue, #06-10, Keppel Bay Tower, Singapore 098632
Tel: <65> 6213-0200, Fax: <65> 6278-8001