



The Future of Analog IC Technology®

# EV3213DH-00A

## 700KHz/1.3MHz Boost Converter with a 3.5A Switch Evaluation Board

### DESCRIPTION

The EV3213DH-00A is an evaluation board for the MP3213. It is configured to provide a regulated 12V output at up to 0.5A from a 5V input. The output is adjustable from  $V_{IN}$  up to 22V by changing resistors on the evaluation board. For an even higher output voltage, the input voltage needs to be extended higher.

The high switching frequency (700KHz or 1.3MHz) of the MP3213 allows for smaller external components, producing a compact solution for a wide range of load currents. Two user-selectable frequency options offer flexibility for easy filtering and low noise. The PCB heatsink with the exposed pad improves thermal performance and efficiency at medium to heavy loads.

### ELECTRICAL SPECIFICATIONS

Parameter	Symbol	Value	Units
Input Voltage	$V_{IN}$	2.5 - 10	V
Frequency Select	$f_{SEL}$	1.3	MHz
Output Current	$I_{OUT}$	0.5	A
Output Voltage	$V_{OUT}$	12	V

### FEATURES

- Pin Selectable 700KHz or 1.3MHz Fixed Switching Frequency
- Operates with Input Voltage as Low as 2.5V
- 12V at 500mA from 5V Input
- Fully Assembled and Tested

### APPLICATIONS

- LCD Displays
- Portable Applications
- Handheld Computers and PDAs
- Digital Still and Video Cameras

"MPS" and "The Future of Analog IC Technology" are Trademarks of Monolithic Power Systems, Inc.

## EV3213DH-00A EVALUATION BOARD



(L x W x H) 2.1" x 2.1" x 0.5"  
(5.4cm x 5.4cm x 1.1cm)

Board Number	MPS IC Number
EV3213DH-00A	MP3213DH

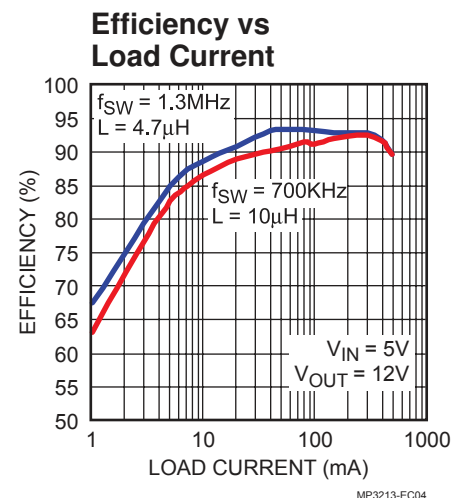

## EVALUATION BOARD SCHEMATIC

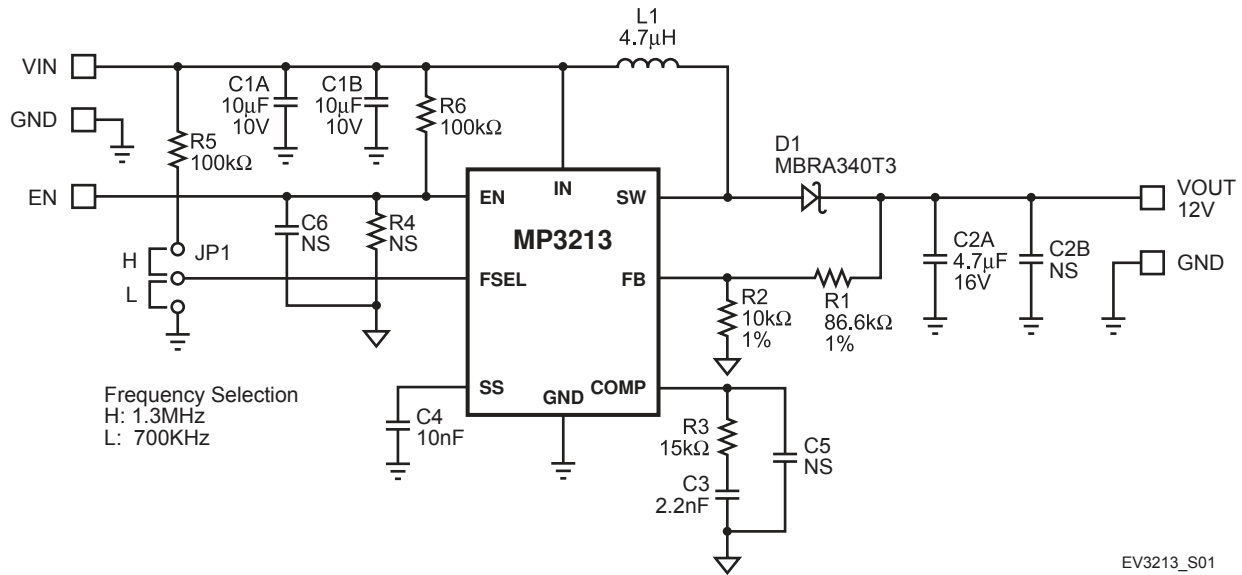

## EV3213DH-00A BILL OF MATERIALS

Qty	Ref	Value	Description	Package	Manufacturer P/N
2	C1A, C1B	10µF	Ceramic Capacitor, 10V, X7R	1210	TDK: C3225X5R1A106K
1	C2A	4.7µF	Ceramic Capacitor, 16V, X7R	1210	TDK: C3225X7R1C475K
1	C3	2.2nF	Ceramic Capacitor, 50V, X7R	0603	TDK: C1608X7R1H222K
1	C4	10nF	Ceramic Capacitor, 50V, X7R	0603	TDK: C1608X7R1H103K
3	C5, C6, C2B		Not Stuffed		
1	D1		Schottky Diode, 40V, 3A	SMA	Diodes Inc. MBRA340T3
1	JP1		3-Pin Connector Header, 0.100		Sullins: PTC03SAAN
1	L1	4.7µH	Inductor, 3.3A, DS84LC	SMD	Toko: B1015AS-4R7N
			Inductor, 4.1A	SMD	Sumida: CDRH8D43-4R7NC
1	R1	86.6kΩ	Resistor, 1%	0603	Panasonic: ERJ-3EKF8662V
1	R2	10kΩ	Resistor, 1%	0603	Panasonic: ERJ-3EKF1002V
1	R3	15kΩ	Resistor, 5%	0603	Panasonic: ERJ-3GEYJ153V
1	R4		Not Stuffed		
2	R5, R6	100kΩ	Resistor, 5%	0603	Panasonic: ERJ-3GEYJ104V
1	U1		DC-DC Converter	MSOP8	MPS: MP3213DH

**PRINTED CIRCUIT BOARD LAYOUT**

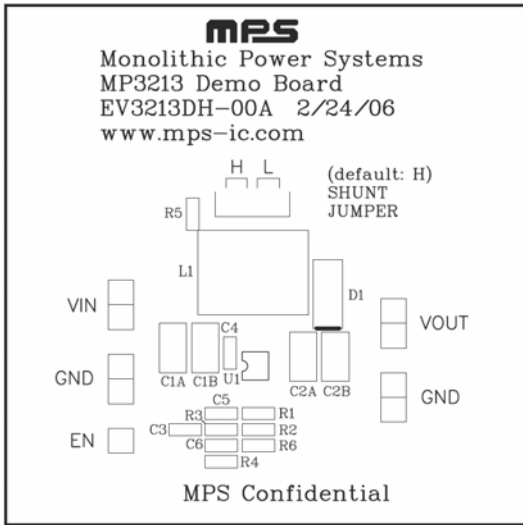

**Figure 1—Top Silk Layer**

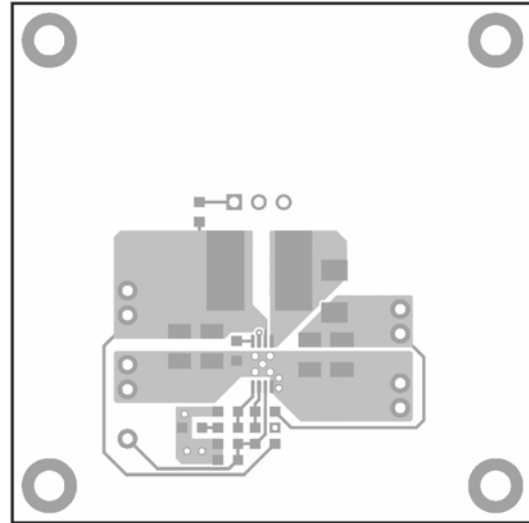

**Figure 2—Top Layer**

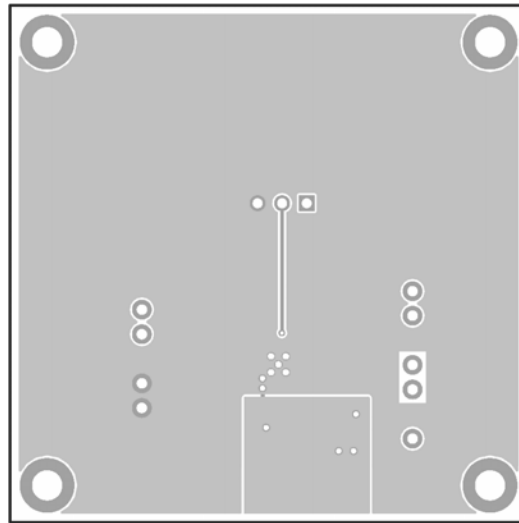

**Figure 3—Bottom Silk Layer**

## QUICK START GUIDE

The output voltage of this board is set to 12V. The board layout accommodates most commonly used inductors and output capacitors.

1. Preset Power Supply to  $2.5V \leq V_{IN} \leq 10V$ .
2. Turn Power Supply off.
3. Place jumper J1 at the H position for 1.3MHz operation, or at the L position for 700KHz operation (the inductor may need to be adjusted accordingly).
4. Connect the power supply terminals to:
  - Positive (+): VIN
  - Negative (-): GND
5. Connect the load to:
  - Positive (+): VOUT
  - Negative (-): GND
6. Turn on the power supply after making connections.
7. The MP3213 is enabled automatically on the evaluation board once  $V_{IN}$  is applied. To disable the MP3213, pull EN low.
8. The output voltage  $V_{OUT}$  can be changed by varying R1. Calculate the new value using the formula:

$$R1 = \left( \frac{V_{OUT}}{V_{FB}} - 1 \right) R2$$

Where  $V_{FB} = 1.25V$  and  $R2 = 10k\Omega$

For example, for  $V_{OUT} = 15V$

$$R1 = \left( \frac{15V}{1.25V} - 1 \right) \times 10k\Omega = 110k\Omega$$

Therefore use a 110k $\Omega$  standard 1% value.

**NOTICE:** The information in this document is subject to change without notice. Please contact MPS for current specifications. Users should warrant and guarantee that third party Intellectual Property rights are not infringed upon when integrating MPS products into any application. MPS will not assume any legal responsibility for any said applications.