

REVISIONS			
LTR	DESCRIPTION	DATE	APPROVED
A	REVISED PER ECN T-20200	95JUN26	Z.T.
B	REVISED PER ECN T-20253		

NOTES:

1 HOLE PATTERN MACHINED SYMMETRIC TO MOUNTING FLANGE.

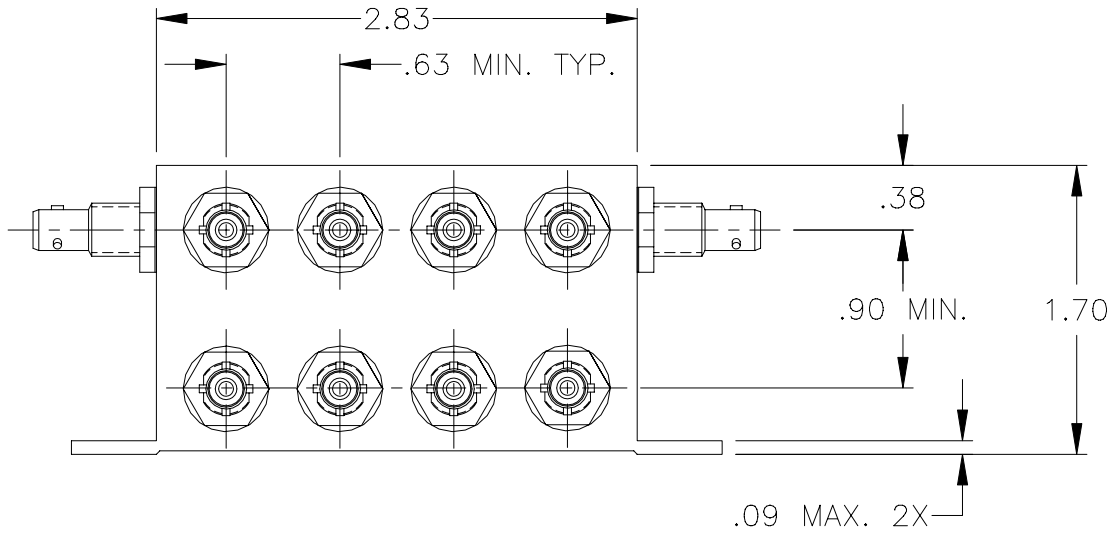
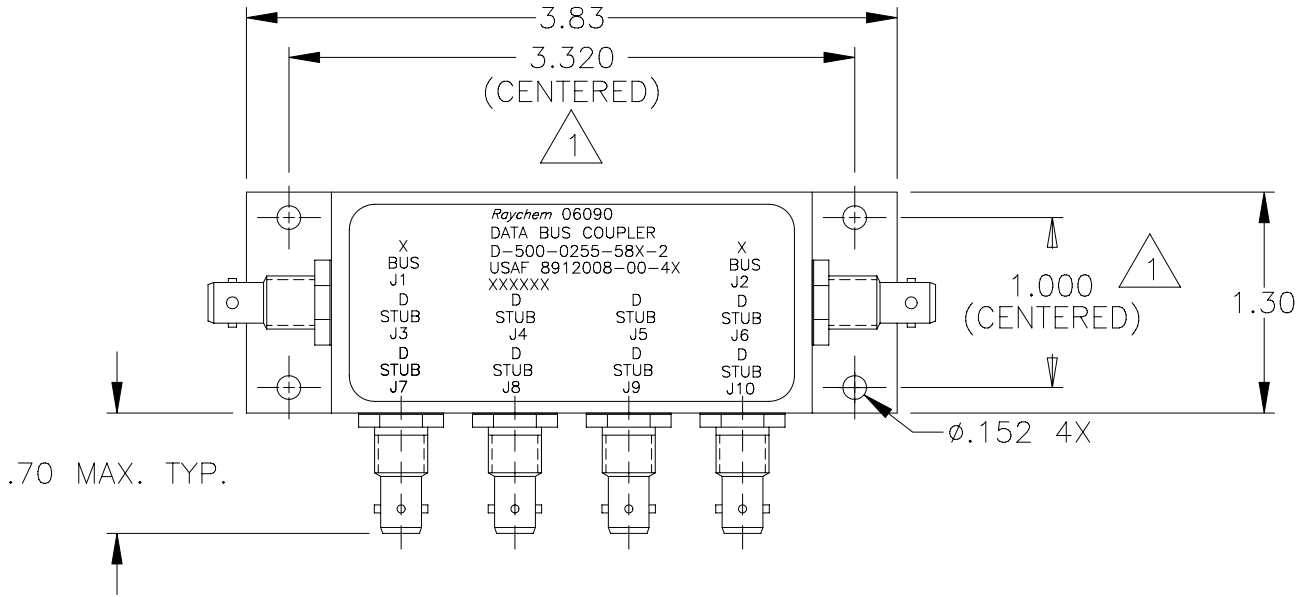

## SPECIFICATION CONTROL DRAWING

If this document is printed it becomes uncontrolled.  
Check for the latest revision.

UNLESS OTHERWISE SPECIFIED DIMENSIONS ARE IN INCHES. METRIC DIMENSIONS ARE IN BRACKETS.  DECIMALS .XXX ± .010 { — mm } .XX ± .03 { — mm } ANGLES .X — ± — WEIGHT 235 GRAMS MAX.	DRAWN	J.B.K.	91 JUN 14		Tyco Electronics Corporation 300 Constitution Drive Menlo Park, CA. 94025 U.S.A.		
	CHECKED						
	APPROVED			TITLE	8 STUB DATA BUS BAYONET COUPLER WITH TRIAXIAL CONNECTORS		
	APPROVED	Z.T.	91JUL08	SIZE	CODE IDENT. NO.	DWG. NO.	REV
CAD NAME	009096-1.DWG			A	06090	D-500-0255-58X-2	B
THIRD ANGLE PROJECTION				DO NOT SCALE THIS DRAWING			SHEET 1 OF 2

1.0 INTERMATEABILITY

CONNECTOR BOX JACK	MATING PLUG	KEY ("X")
DK-621-0434-1S (8912004-00-05)	DK-621-0433-1P (8912003-00-01)	A
DK-621-0436-2S (8912004-00-06)	DK-621-0435-2P (8912003-00-02)	B
DK-621-0438-3S (8912004-0-07)	DK-621-0437-3P (8912003-00-03)	C
DK-621-0440-4P (8912004-00-04)	DK-621-0439-4S (8912003-00-08)	D

2.0 PERFORMANCE

- 2.1 THIS COUPLER IS DESIGNED TO MEET THE APPLICABLE FUNCTIONAL REQUIREMENT OF RAYCHEM SPECIFICATION D-6021 AND USAF 8912008.
- 2.2 THE COUPLER SHALL OPERATE UNDER ANY OF THE ENVIRONMENTAL SERVICE CONDITIONS AS SPECIFIED IN MIL-E-5400, CLASS  $\nabla$  UPGRADED TO 125°C CONTINUOUS OPERATION.
- 2.3 ALTITUDE: SEA LEVEL TO 75,000 FEET
- 3.0

D-500-0255	BUS JACKS J1 AND J2	STUB JACKS J3 THRU J10
-583-2 (8912008-00-46)	DK-621-0434-1S "A" (8912004-00-01)	DK-621-0440-4P "D" (8912004-00-08)
-585-2 (8912008-00-47)	DK-621-0436-2S "B" (8912004-00-02)	DK-621-0440-4P "D" (8912004-00-08)
-587-2 (8912008-00-48)	DK-621-0438-3S "C" (8912004-00-03)	DK-621-0440-4P "D" (8912004-00-08)

SCHEMATIC DIAGRAM

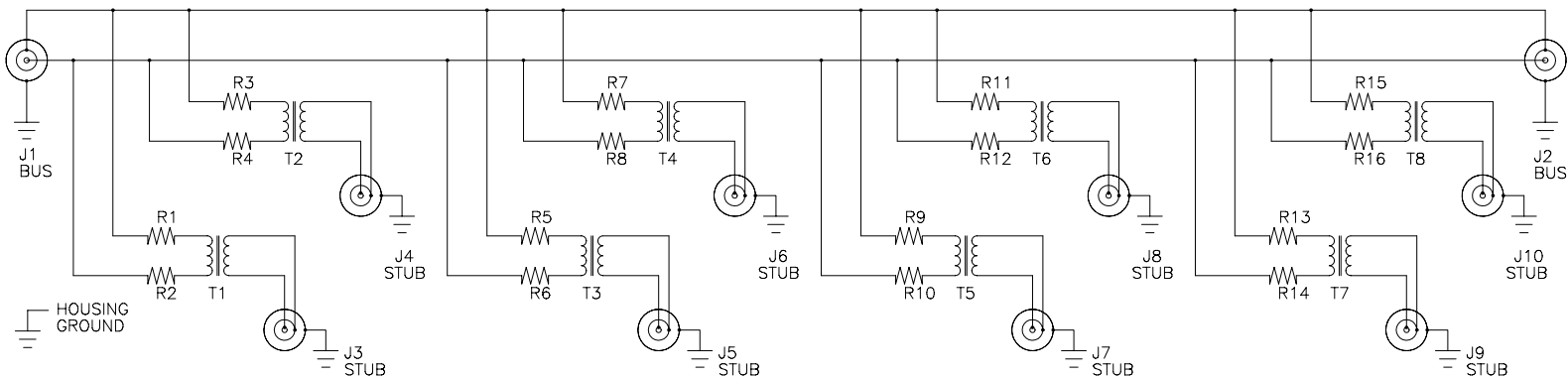

If this document is printed it becomes uncontrolled.  
Check for the latest revision.

CAD NAME: 009096-2	DRAWN	J.B.K.	91 JUN 14	SIZE	CODE IDENT. NO.	DWG. NO.
	ISSUED			A	06090	D-500-0255-58X-2
DO NOT SCALE THIS DRAWING						SHEET 2 OF 2