

PART NUMBER	REVISION	DESCRIPTION	FEED TYPE
2266453-1	C	FINE CRIMP HEIGHT ADJUST	MECHANICAL
2266453-2	C	FINE CRIMP HEIGHT ADJUST	PNEUMATIC
7-2266453-1	C	MECHANICAL AND CRIMP TOOLING KIT	MECHANICAL
7-2266453-2	C	PNEUMATIC AND CRIMP TOOLING KIT	PNEUMATIC
7-2266453-7	A	CRIMP TOOLING KIT	-

ATLANTIC VERSION TERMINATOR INTERFACE ADAPTER



APPLICATOR DATA		
CRIMP	SIZE	TYPE
WIRE	1.78 mm (.070)	F
INSUL	-	-

APPLICATOR INSTRUCTIONS
408-35042

TERMINAL DATA: LEAR TERMINAL		TE CRIMP SPECIFICATION	
TERMINAL NAME: CLIP			
WIRE STRIP LENGTH		INSULATION DIAMETER RANGE	
6.40-6.78 mm [.252-.267 IN]		∅0.00-3.18 mm [.000-.125 IN]	
TERMINAL APPLICATION SPECIFICATION	NONE		
TERMINALS APPLIED			
TE TERMINAL	LEAR TERMINAL	TE TERMINAL	LEAR TERMINAL
2113560-1	25763		

WIRE SIZE	CRIMP HEIGHT mm [INCH]	CRIMP HEIGHT REFERENCE SETTING
1.00mm2	1.30 +/- 0.025 [.051 +/- .001]	8.2
0.75mm2	1.14 +/- 0.025 [.045 +/- .001]	9.8
0.50mm2	1.07 +/- 0.025 [.042 +/- .001]	10.6

- RECOMMENDED SPARE PARTS
- REFER TO SUPPLIED INSTRUCTION SHEET FOR CLEANING, LUBRICATION AND STORAGE OF APPLICATOR.
- CRIMP HEIGHT REFERENCE SETTING WAS THE SETTING USED WHEN THE APPLICATOR WAS QUALIFIED AT THE FACTORY. ADJUSTMENT MAY BE NECESSARY WHEN RUNNING APPLICATOR IN THE FIELD.
- 4. UNLESS SPECIFIED OTHERWISE TORQUE VALUES SHALL BE USED PER DOCUMENT, 101-35000.
- TERMINAL LUBRICANT IS RECOMMENDED.

*WARNING
ON INSTALLATION, SET WIRE DISC TO CRIMP HEIGHT REFERENCE SETTING FOR LARGEST WIRE SIZE. CRIMP HEIGHT REFERENCE SETTINGS GREATER THAN THE VALUE SHOWN MAY CAUSE DAMAGE TO THE CRIMP TOOLING, REFER TO THE INSTRUCTION SHEET FOR PROPER SETUP AND ADJUSTMENTS.

ATLANTIC VERSION
Shown on sheets 1 of 4 & 2 of 4
(Pacific version shown on sheets 3 of 4 & 4 of 4)

LOC	DIST	REVISIONS					
A	66	P	LTN	DESCRIPTION	DATE	OWN	APVD
		1		ORIGINAL	15AUG2014	GH	TE
		A		RELEASED	24OCT2014	GH	TE
		B		ECR-19-001568	30JAN2019	FZ	KZ
		C		ECR-19-002522	15FEB2019	TB	GB

-	1	-	1	-	2119640-1	PUSH ROD, AIR FEED	250	
-	1	-	1	-	1803259-1	BUSHING, FLANGED	249	
-	1	-	1	-	2119641-1	FEED CAM, AIR FEED	248	
-	1	1	1	1	7-18023-7	SCR, SKT HD CAP M3 X 4.0	241	
-	-	1	-	1	2119580-1	MECHANICAL FEED ASSEMBLY	239	
-	1	-	1	-	2063440-1	AIR FEED MODULE	238	
-	2	-	2	-	21045-3	RING, RETAIN, EXTERN, 3/16 CRESCENT	172	
-	REF	REF	REF	REF	994970-2	COUNTER, MAGNETIC	164	
-	1	-	1	-	240638-1	SPRING, FEED FINGER	163	
-	1	-	1	-	3-23627-7	PIN, RETAIN, GRVD, 3/16 X .854	137	
-	1	-	1	-	2119799-1	HOLDER, FEED FINGER, AF	136	
	1	1	1	1	2119955-1	ASSY, LUBRICATOR, SIDE FEED	113	
-	1	1	1	1	2844908-1	SCREW, LOCKING	99	
-	1	1	1	1	2844907-1	POST, LOCKING	98	
-	1	1	1	1	455888-4	SPACER, CRIMPER	82	
-	1	1	1	1	1803607-1	DOCUMENTATION PACKAGE	71	
-	1	1	1	1	2119740-1	TAG, IDENTIFICATION	67	
-	2	2	2	2	2168078-1	SCREW, DRIVE, RH, RoHS, 2 x .188	66	
-	1	1	1	1	2168083-2	SCR, SKT HD CAP, RoHS, M4 X 8.0	60	
-	1	1	1	1	5-18022-5	SCR, HEX HD CAP, M4 X 6.0	59	
-	1	1	1	1	1338685-1	PAWL, FEED	56	
-	2	2	2	2	2168083-3	SCR, SKT HD CAP, RoHS, M4 X 12.0	54	
-	1	2	1	2	18023-9	SCR, SKT HD CAP M4 X 6.0	49	
-	-	1	-	1	2119652-1	FEED CAM, PRE FEED	48	
-	-	1	-	1	2119653-1	FEED CAM, POST FEED	47	
-	1	1	1	1	1803583-9	APPLICATOR BASIC ASSEMBLY, SF	46	
-	1	1	1	1	1803515-1	RAM ASSEMBLY, SF ATLANTIC	44	
-	1	1	1	1	1803602-1	SCR, BHSC, RoHS (M8 X 25)	41	
-	2	2	2	2	2079383-5	SCR, BHSC, RoHS (M4 X 20)	33	
-	2	2	2	2	2-2844962-0	SPACER, CYLINDRICAL, STRIP GUIDE	30	
-	1	1	1	1	2844992-1	ASSEMBLY, STRIP GUIDE	29	
-	1	1	1	1	455888-3	SPACER, CRIMPER	28	
-	1	1	1	1	1320928-2	STRIP GUIDE	24	
-	1	1	1	1	2168083-2	SCR, SKT HD CAP, RoHS, M4 X 8.0	21	
-	2	2	2	2	1-18028-2	WASHER, FLAT, REG M4	20	
-	1	1	1	1	2119533-1	STRIPPER, SIDE FEED	19	
	1	1	1	1	2119806-1	INSERT, SHEAR	13	
-	1	1	1	1	3-22280-3	SPRING, COMPRESSION	12	
-	1	1	1	1	1-356885-4	STOP, SHEAR	11	
	1	1	1	1	2119805-1	SHEAR HOLDER, FRONT	10	
	1	1	1	1	1803095-1	FLOATING SHEAR, FRONT	9	
	1	2	2	1	1	3-1633933-5	ANVIL, COMBINATION	8
-	-	-	-	-	-	-	7	
-	-	-	-	-	-	-	6	
-	1	1	1	1	2119757-8	DEPRESSOR, SHEAR	5	
-	-	-	-	-	-	-	4	
-	-	-	-	-	-	-	3	
-	-	-	-	-	-	-	2	
	1	2	2	1	1	5-1333281-1	CRIMPER, WIRE PREMIUM	1

DIMENSIONS:		TOLERANCES UNLESS OTHERWISE SPECIFIED:		MATERIAL:		FINISH:		WEIGHT:		SCALE:		SHEET:		REV:				
mm	0 PLC ±	1 PLC ±	2 PLC ±	3 PLC ±	4 PLC ±	ANGLES	FINISH			Customer Accessible Production Drawing	SCALE	1:2	SHEET	1	OF	4	REV	C



Ocean Side Feed
Applicator

SIZE: A1 CAGE CODE: 00779 DRAWING NO: 2266453

LOC	DIST	REVISIONS					
A	66	P	LTN	DESCRIPTION	DATE	OWN	APVD
		-		SEE SHEET 1			

FEED TYPE MECHANICAL

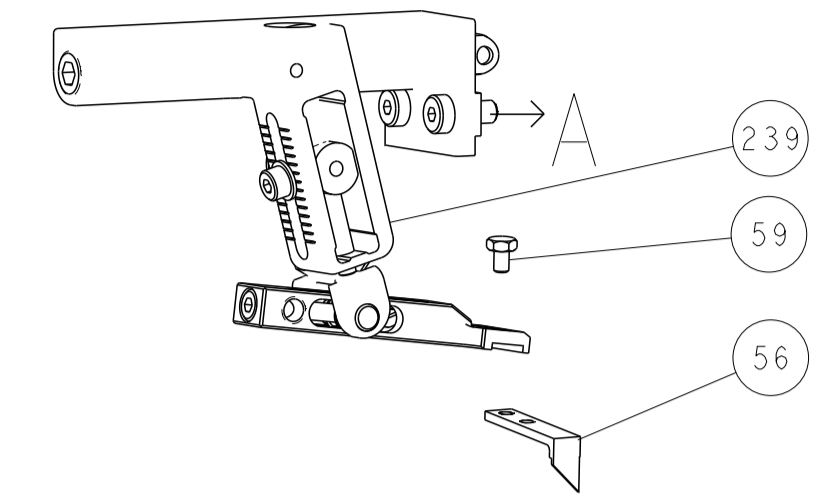

PNEUMATIC

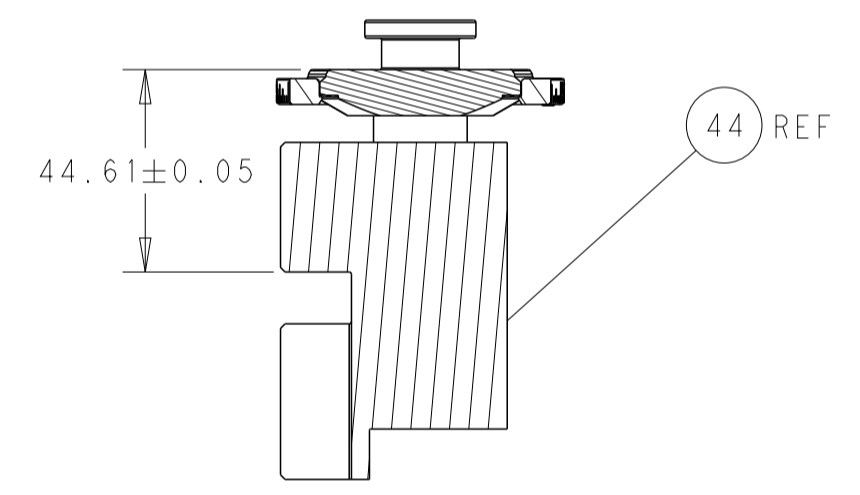
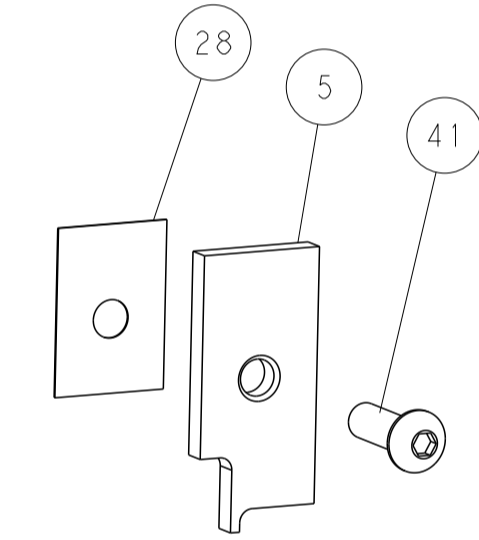
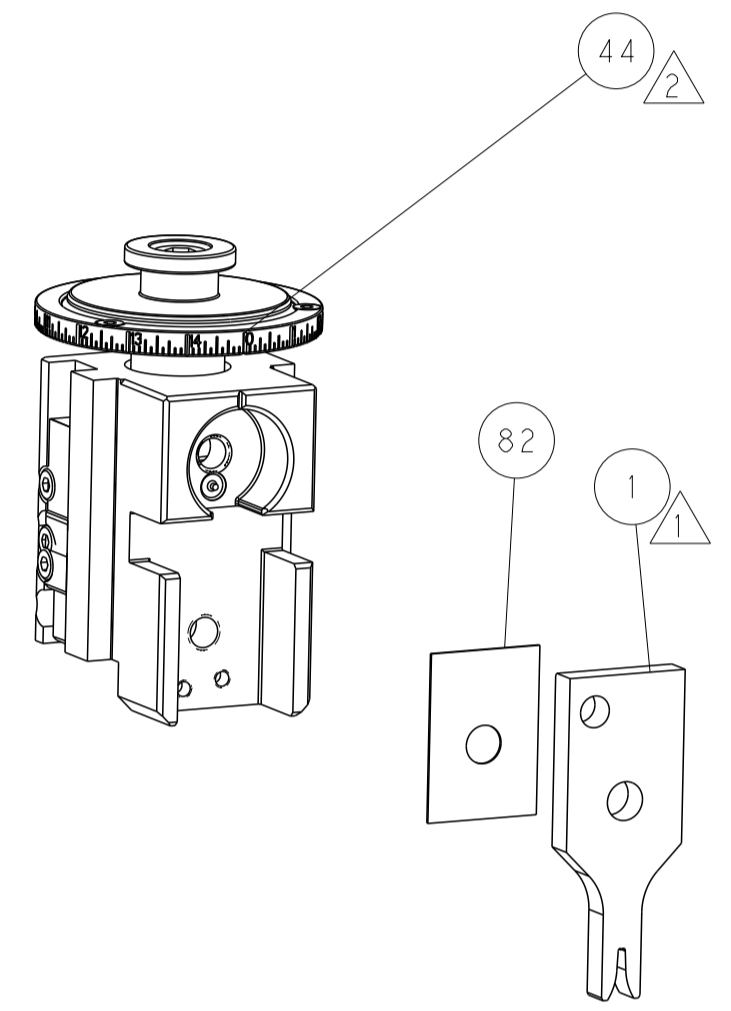
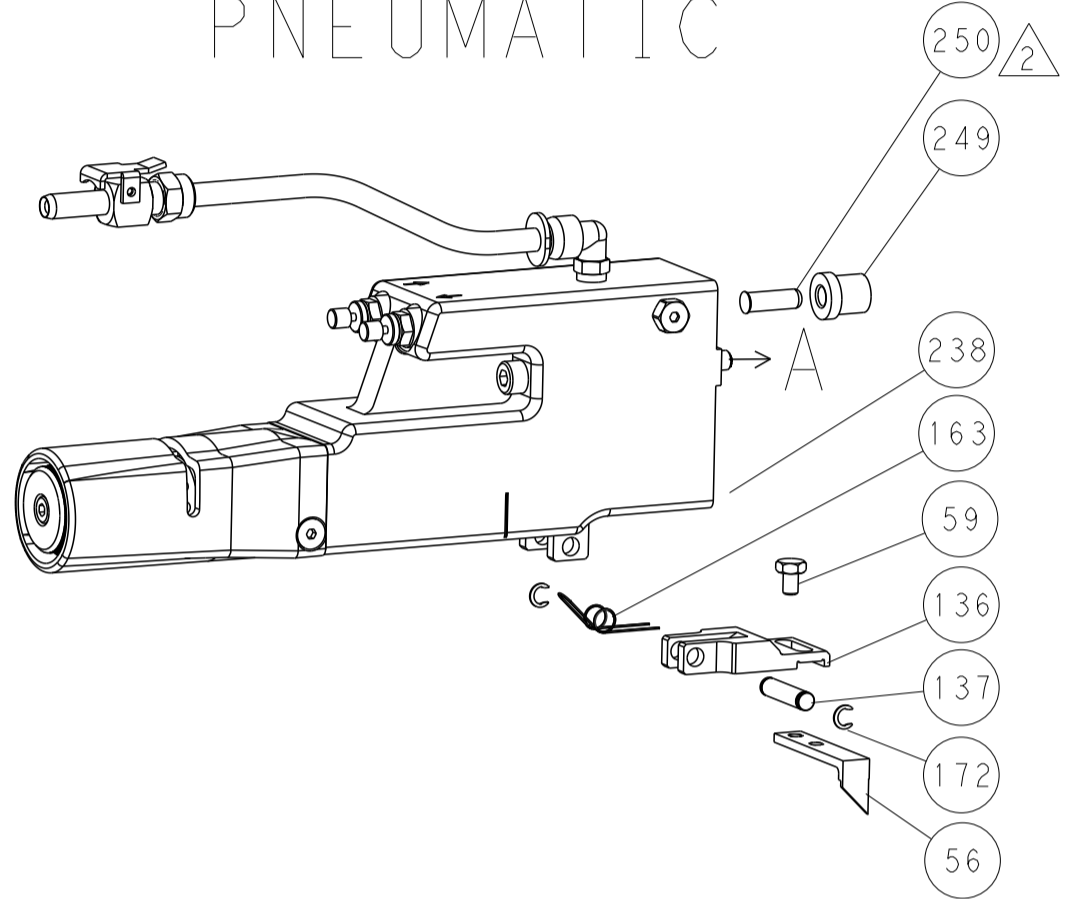

RAM SET-UP

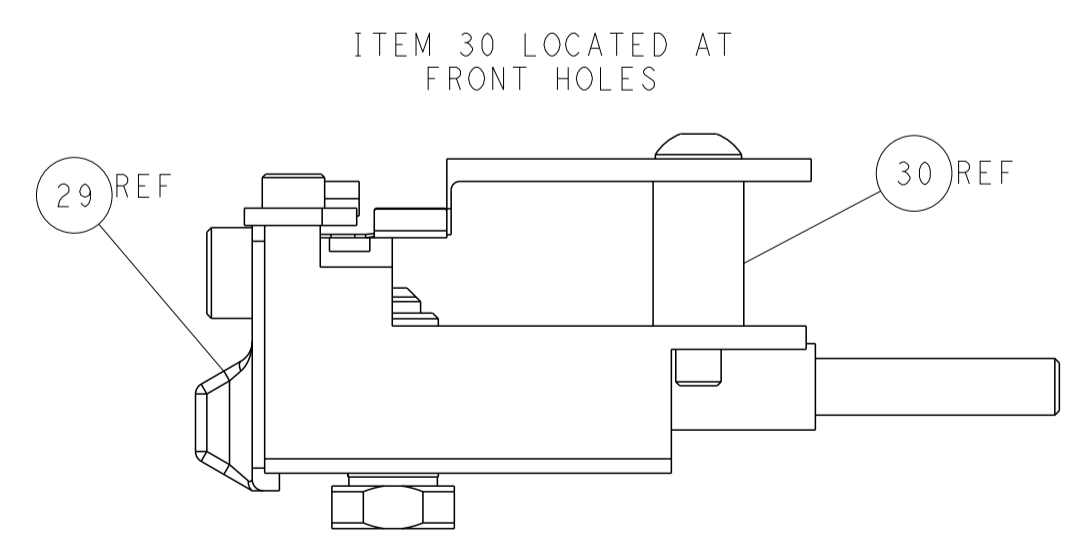
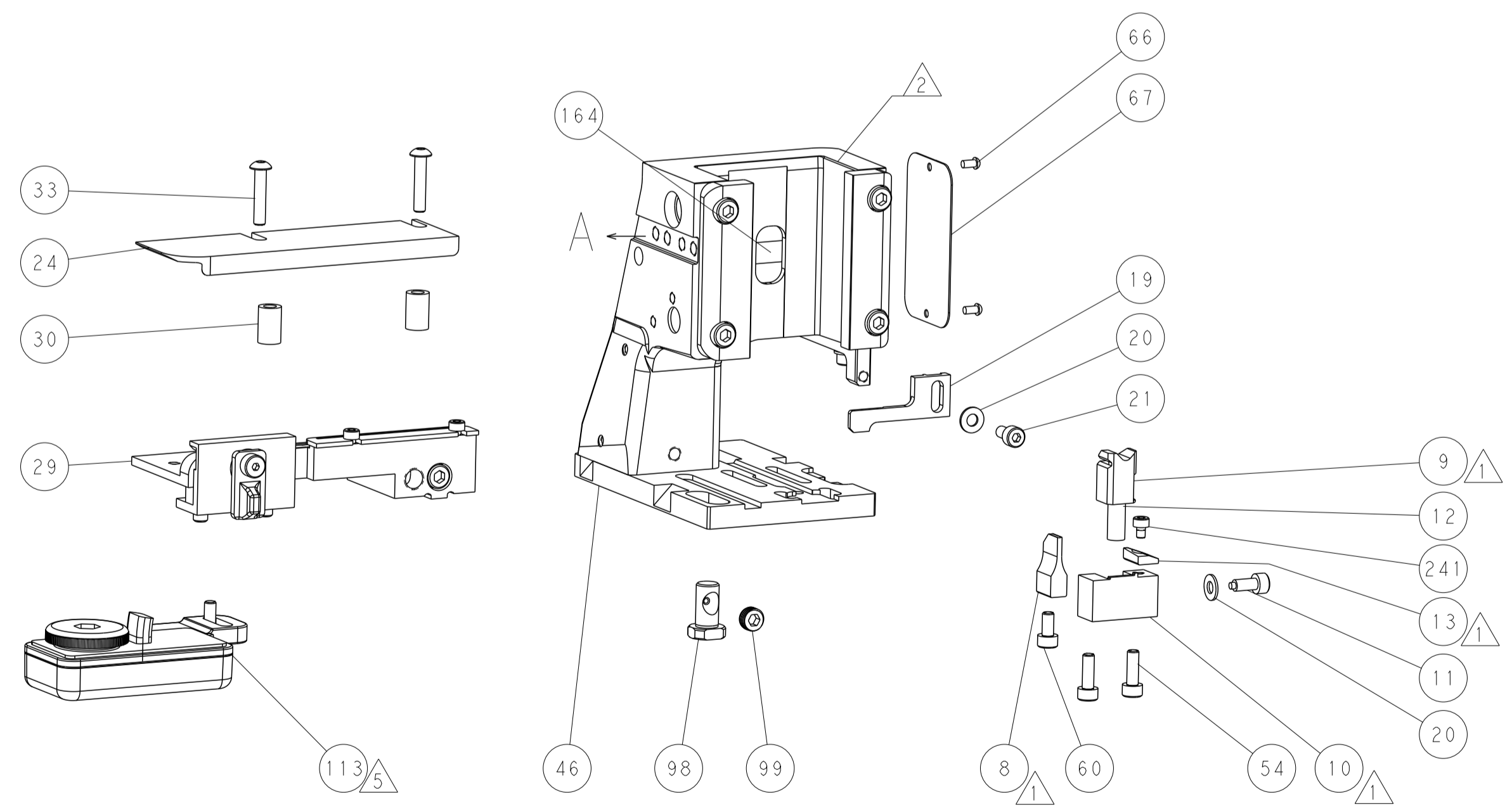

FEED TRACK POSITION GUIDE BY WIRE BARREL

CAM POSITIONS

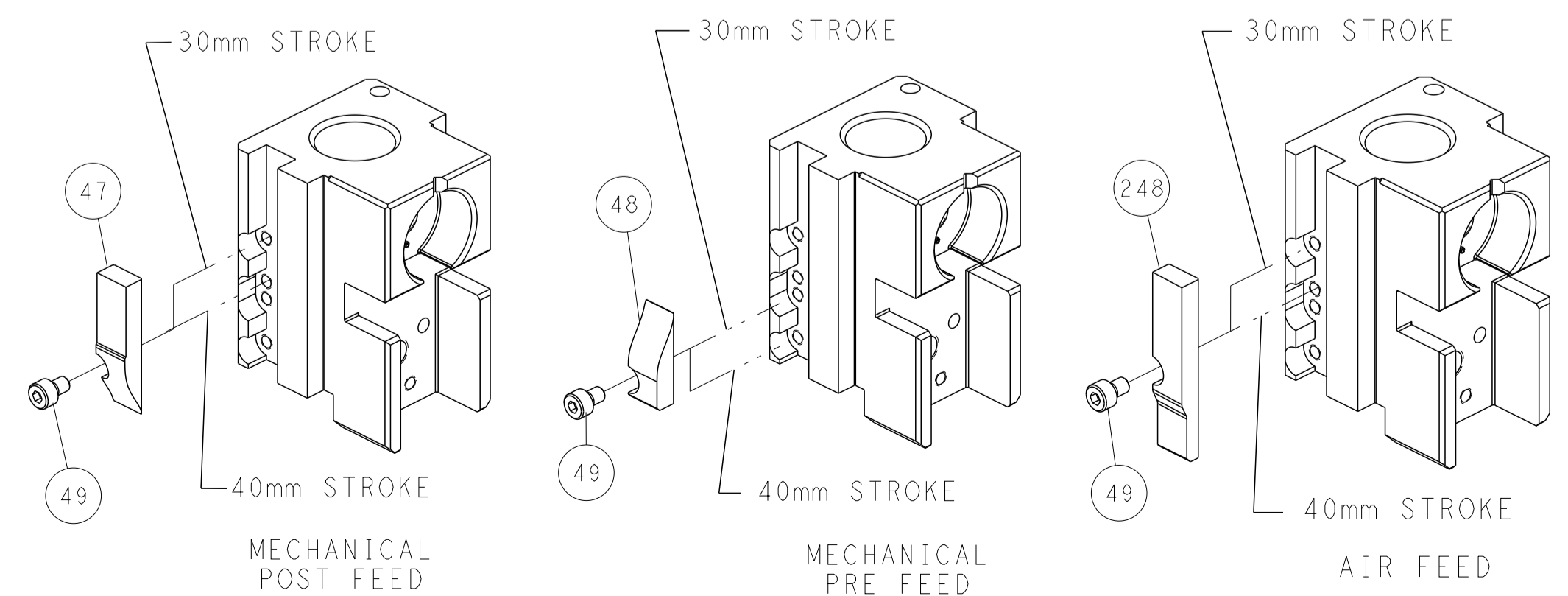

ATLANTIC VERSION
 Shown on sheets 1 of 4 & 2 of 4
 (Pacific version shown on sheets 3 of 4 & 4 of 4)

DIMENSIONS: mm 		TOLERANCES UNLESS OTHERWISE SPECIFIED: 0 PLC ± 1 PLC ± 2 PLC ± 3 PLC ± 4 PLC ± ANGLES ± FINISH		DWN: HOFFNER 14AUG2014 CHK: T. ELBIN 15AUG2014 APVD: T. ELBIN 15AUG2014 PRODUCT SPEC APPLICATION SPEC WEIGHT Customer Accessible Production Drawing		NAME: Ocean Side Feed Applicator SIZE: A1 CAGE CODE: 00779 DRAWING NO: 2266453 SCALE: 1:2 SHEET: 2 of 4 REV: C	
-----------------------	--	---	--	---	--	--	--

PART NUMBER	REVISION	DESCRIPTION	FEED TYPE
2-2266453-1	C	FINE CRIMP HEIGHT ADJUST	MECHANICAL
2-2266453-2	C	FINE CRIMP HEIGHT ADJUST	PNEUMATIC
7-2266453-7	A	CRIMP TOOLING KIT	-

PACIFIC VERSION TERMINATOR
 INTERFACE ADAPTER



APPLICATOR DATA		
CRIMP	SIZE	TYPE
WIRE	1.78 mm [.070]	F
INSUL	-	-

APPLICATOR INSTRUCTIONS
 408-35042

TERMINAL DATA: LEAR TERMINAL		TE CRIMP SPECIFICATION	
TERMINAL NAME: CLIP			
WIRE STRIP LENGTH 6.40-6.78 mm [.252-.267 IN]		INSULATION DIAMETER RANGE Ø0.00-3.18 mm [.000-.125 IN]	
TERMINAL APPLICATION SPECIFICATION NONE			
TERMINALS APPLIED			
TE TERMINAL	LEAR TERMINAL	TE TERMINAL	LEAR TERMINAL
2113560-1	25763		

WIRE SIZE	CRIMP HEIGHT mm [INCH]	CRIMP HEIGHT REFERENCE SETTING
1.00mm2	1.30+/-0.025 [.051+/- .001]	8.2
0.75mm2	1.14+/-0.025 [.045+/- .001]	9.8
0.50mm2	1.07+/-0.025 [.042+/- .001]	10.6

- RECOMMENDED SPARE PARTS
- REFER TO SUPPLIED INSTRUCTION SHEET FOR CLEANING, LUBRICATION AND STORAGE OF APPLICATOR.
- CRIMP HEIGHT REFERENCE SETTING WAS THE SETTING USED WHEN THE APPLICATOR WAS QUALIFIED AT THE FACTORY. ADJUSTMENT MAY BE NECESSARY WHEN RUNNING APPLICATOR IN THE FIELD.
- UNLESS SPECIFIED OTHERWISE TORQUE VALUES SHALL BE USED PER DOCUMENT, 101-35000.
- TERMINAL LUBRICANT IS RECOMMENDED.

***WARNING**
 ON INSTALLATION, SET WIRE DISC TO CRIMP HEIGHT REFERENCE SETTING FOR LARGEST WIRE SIZE. CRIMP HEIGHT REFERENCE SETTINGS GREATER THAN THE VALUE SHOWN MAY CAUSE DAMAGE TO THE CRIMP TOOLING, REFER TO THE INSTRUCTION SHEET FOR PROPER SETUP AND ADJUSTMENTS.

PACIFIC VERSION
 Shown on sheets 3 of 4 & 4 of 4
 (Atlantic version shown on sheets 1 of 4 & 2 of 4)

LOC	DIST	REVISIONS					
A	66	P	LTN	DESCRIPTION	DATE	OWN	APVD
-	-	-	-	SEE SHEET 1	-	-	-

-	1	-	2119640-1	PUSH ROD, AIR FEED	250	
-	1	-	1803259-1	BUSHING, FLANGED	249	
-	1	1	7-18023-7	SCR, SKT HD CAP M3 X 4.0	241	
-	-	1	2119580-1	MECHANICAL FEED ASSEMBLY	239	
-	1	-	2063440-1	AIR FEED MODULE	238	
-	2	-	21045-3	RING, RETAIN, EXTERN, 3/16 CRESCENT	172	
-	REF	REF	994970-2	COUNTER, MAGNETIC	164	
-	1	-	240638-1	SPRING, FEED FINGER	163	
-	1	-	2119641-2	FEED CAM, AIR FEED	151	
-	1	1	2168083-8	SCR, SKT HD CAP, RoHS, M4 X 16	144	
-	2	2	2168083-9	SCR, SKT HD CAP, RoHS, M4 X 20	143	
-	-	1	2119653-2	FEED CAM, POST FEED	142	
-	1	1	1-1803583-0	APPLICATOR BASIC ASSEMBLY, SF	141	
-	1	1	1803516-1	RAM ASSEMBLY, SF PACIFIC	140	
-	1	-	3-23627-7	PIN, RETAIN, GRVD, 3/16 X .854	137	
-	1	-	2119799-1	HOLDER, FEED FINGER, AF	136	
-	1	1	2119955-1	ASSY, LUBRICATOR, SIDE FEED	113	
-	1	1	2844908-1	SCREW, LOCKING	99	
-	1	1	2844907-1	POST, LOCKING	98	
-	1	1	455888-4	SPACER, CRIMPER	82	
-	1	1	1803607-1	DOCUMENTATION PACKAGE	71	
-	1	1	2119740-1	TAG, IDENTIFICATION	67	
-	2	2	2168078-1	SCREW, DRIVE, RH, RoHS, 2 x .188	66	
-	1	1	5-18022-5	SCR, HEX HD CAP, M4 X 6.0	59	
-	1	1	1338685-1	PAWL, FEED	56	
-	1	2	18023-9	SCR, SKT HD CAP M4 X 6.0	49	
-	-	1	2119652-1	FEED CAM, PRE FEED	48	
-	1	1	1803602-1	SCR, BHSC, RoHS (M8 X 25)	41	
-	2	2	2079383-5	SCR, BHSC, RoHS (M4 X 20)	33	
-	2	2	2-2844962-0	SPACER, CYLINDRICAL, STRIP GUIDE	30	
-	1	1	2844992-1	ASSEMBLY, STRIP GUIDE	29	
-	1	1	455888-3	SPACER, CRIMPER	28	
-	1	1	1320928-2	STRIP GUIDE	24	
-	1	1	2168083-2	SCR, SKT HD CAP, RoHS, M4 X 8.0	21	
-	2	2	1-18028-2	WASHER, FLAT, REG M4	20	
-	1	1	2119533-1	STRIPPER, SIDE FEED	19	
-	1	1	2119806-1	INSERT, SHEAR	13	
-	1	1	3-22280-3	SPRING, COMPRESSION	12	
-	1	1	1-356885-4	STOP, SHEAR	11	
-	1	1	2119805-1	SHEAR HOLDER, FRONT	10	
-	1	1	1803095-1	FLOATING SHEAR, FRONT	9	
-	1	1	1	3-1633933-5	ANVIL, COMBINATION	8
-	-	-	-	-	7	
-	-	-	-	-	6	
-	1	1	2119757-8	DEPRESSOR, SHEAR	5	
-	-	-	-	-	4	
-	-	-	-	-	3	
-	-	-	-	-	2	
-	1	1	1	5-1333281-1	CRIMPER, WIRE PREMIUM	1

DIMENSIONS:		TOLERANCES UNLESS OTHERWISE SPECIFIED:		MATERIAL:		FINISH:		WEIGHT:		SCALE:	
mm	0 PLC ±	1 PLC ±	2 PLC ±	3 PLC ±	4 PLC ±	ANGLES	FINISH				

OWN	HOFFNER	14AUG2014
CHK	T. ELBIN	15AUG2014
APVD	T. ELBIN	15AUG2014
NAME	Ocean Side Feed Applicator	
SIZE	CAGE CODE	DRAWING NO
A1	00779	2266453
Customer Accessible Production Drawing		
SCALE	1:2	SHEET 3 OF 4

LOC	DIST	REVISIONS					
		P	LTN	DESCRIPTION	DATE	DMN	APVD
A	66	-	-	SEE SHEET 1	-	-	-

FEED TYPE MECHANICAL

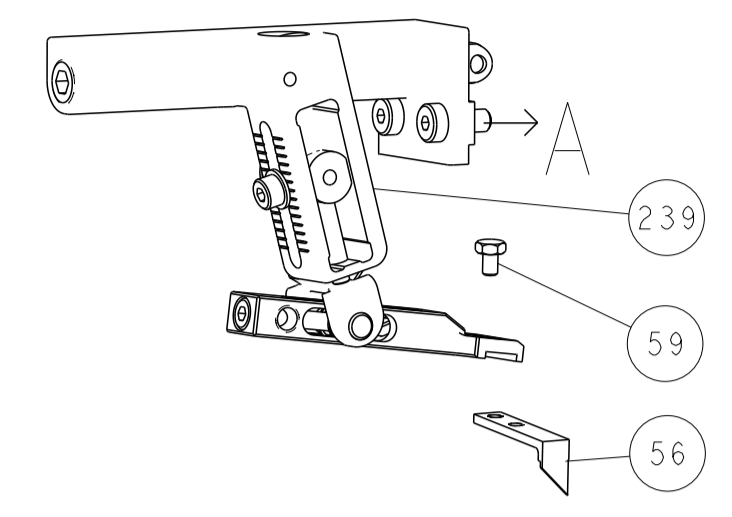

PNEUMATIC

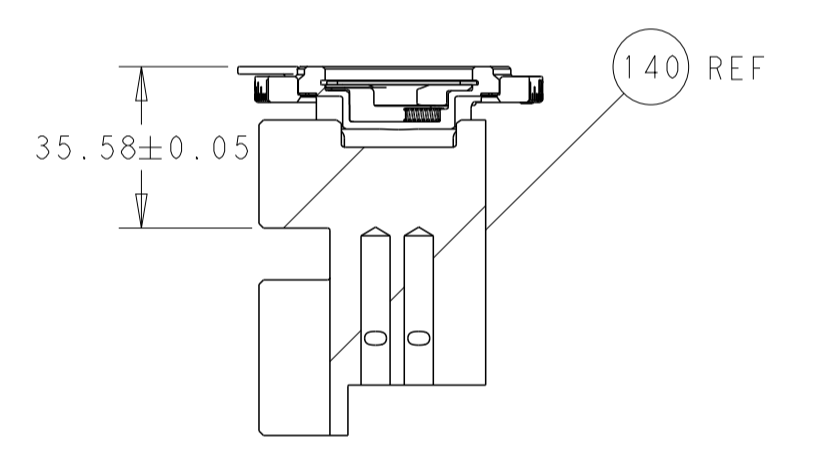
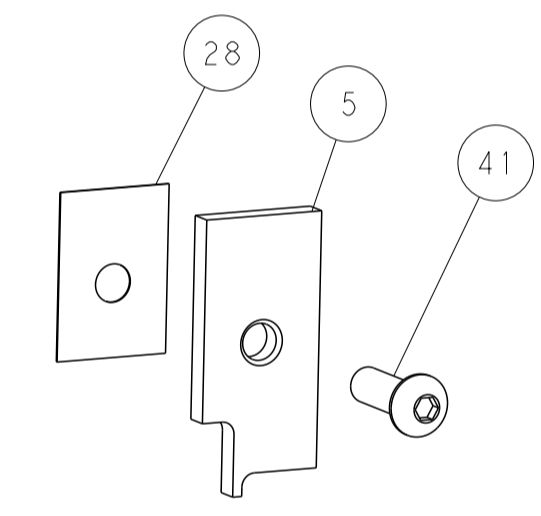
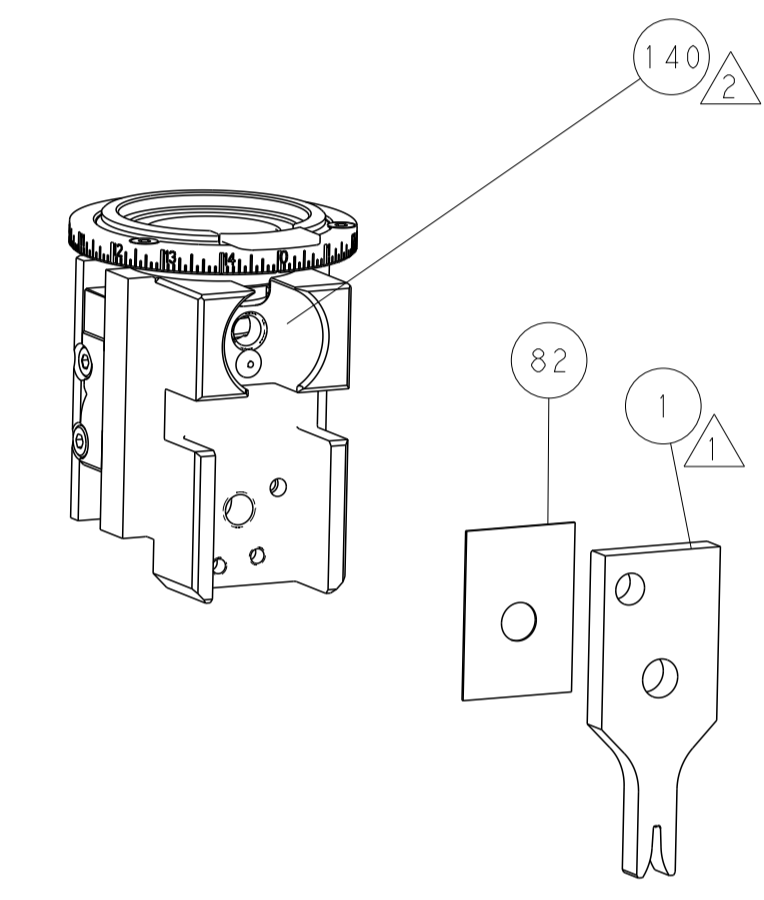
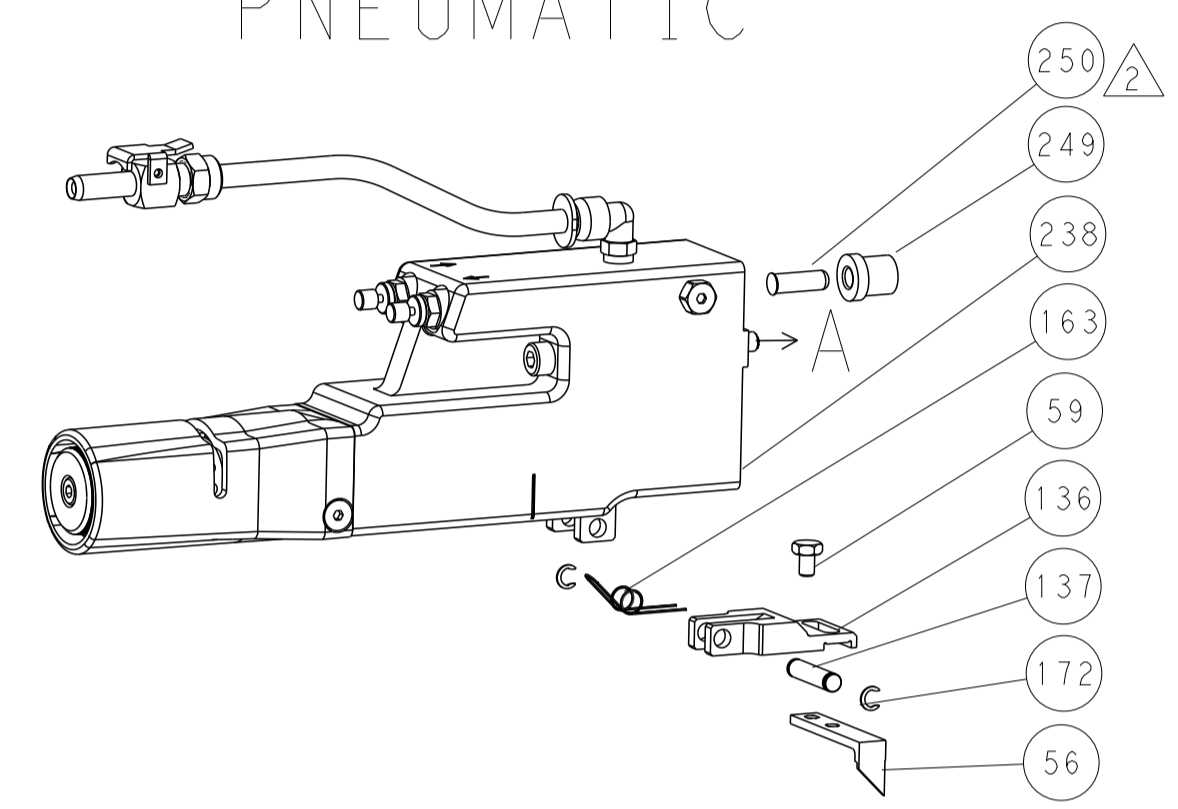

CAM POSITIONS

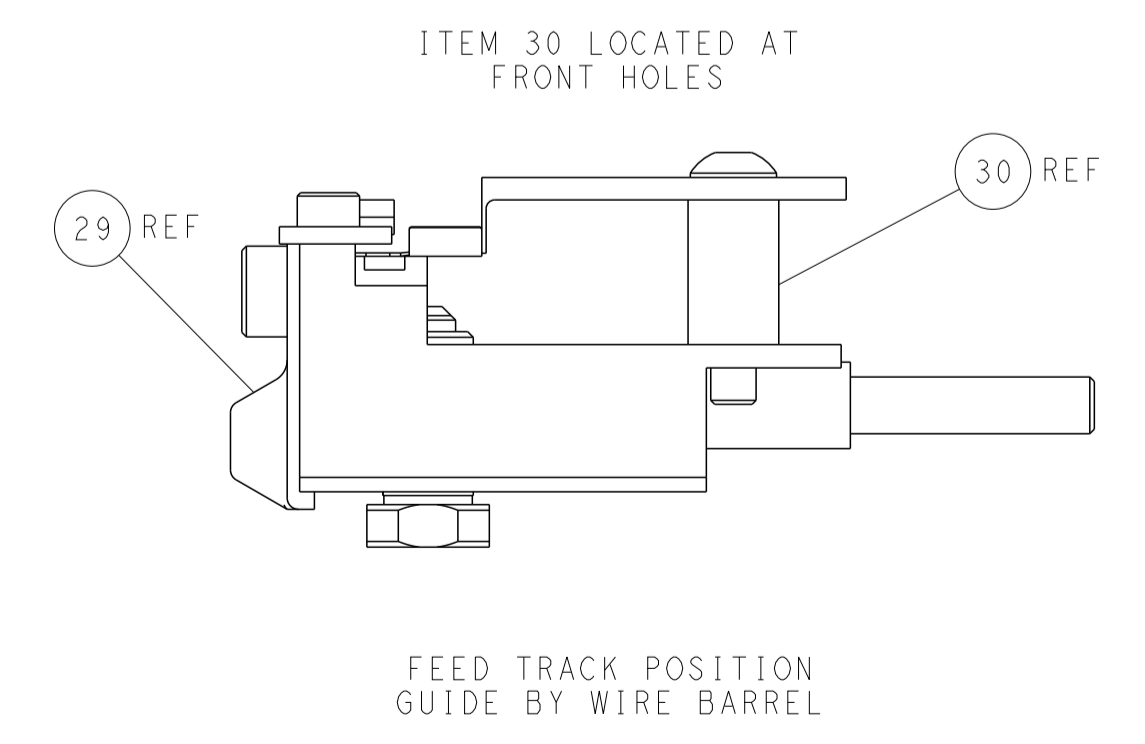
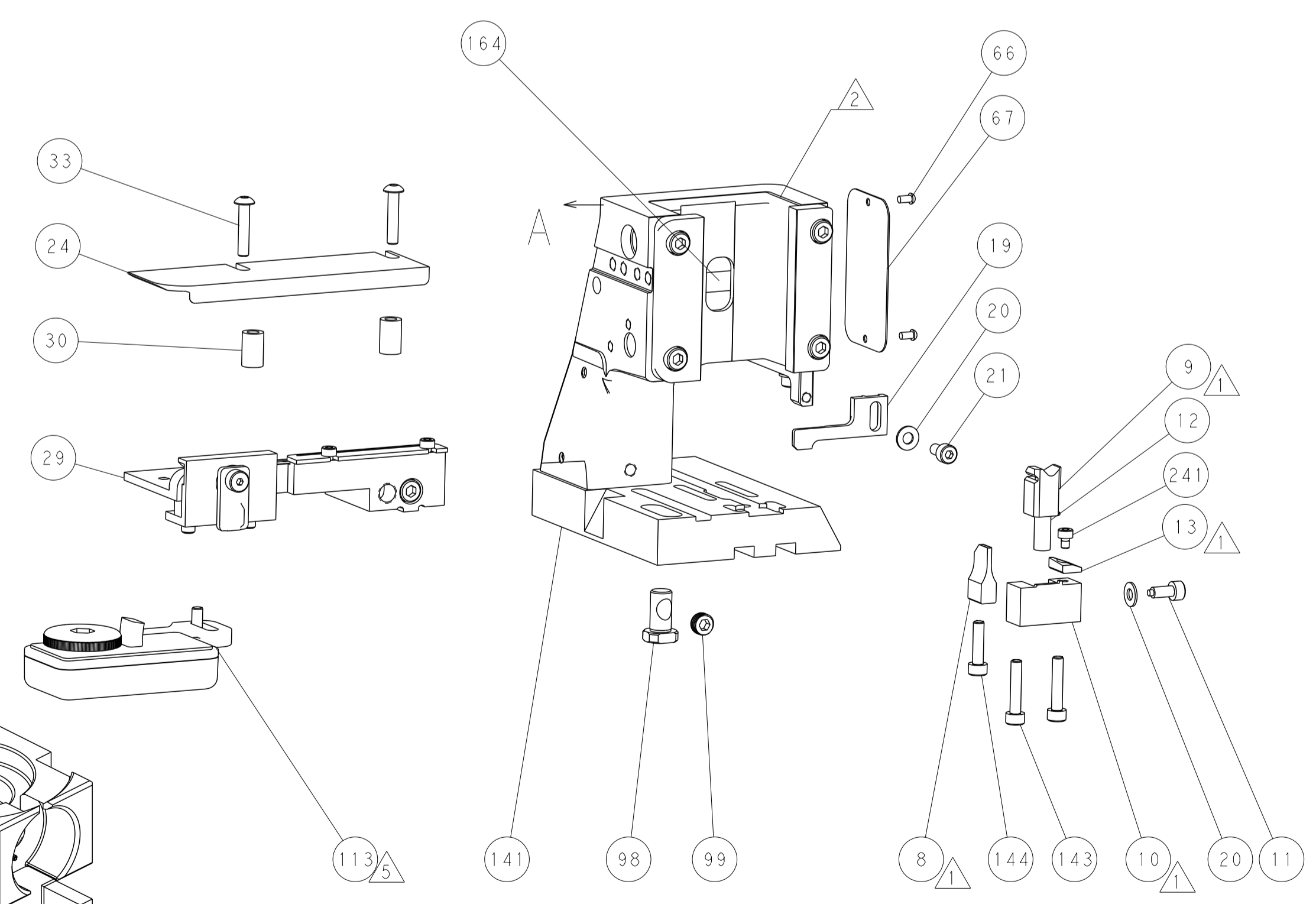
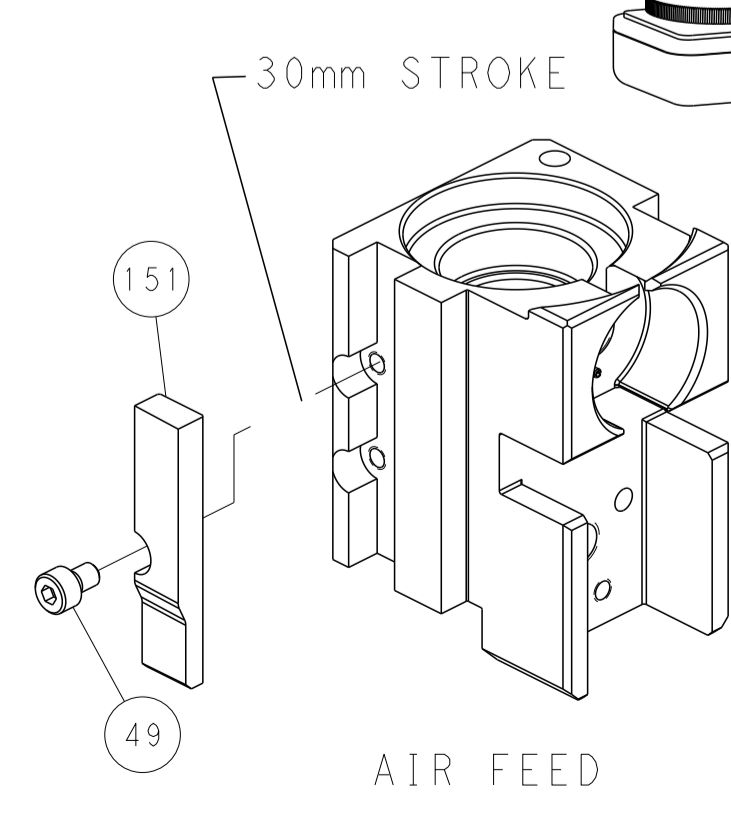
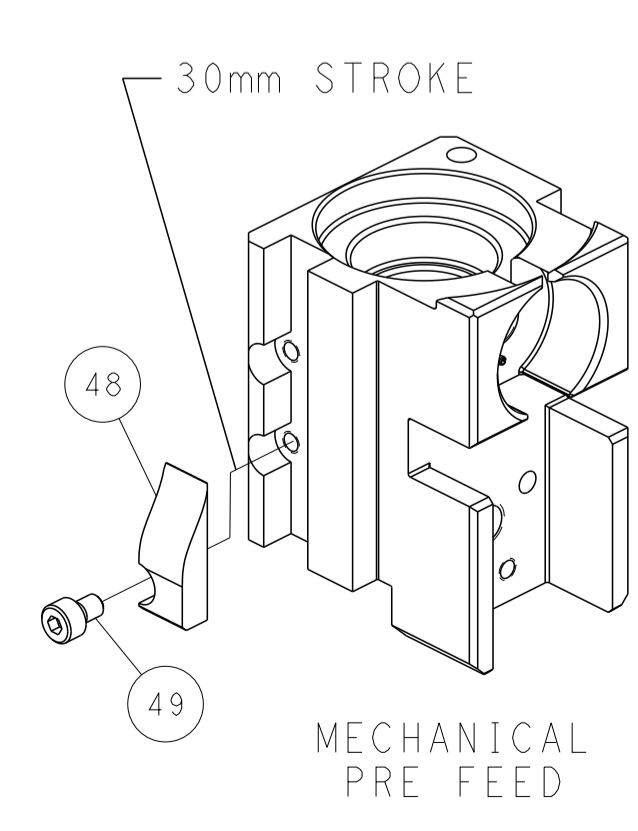
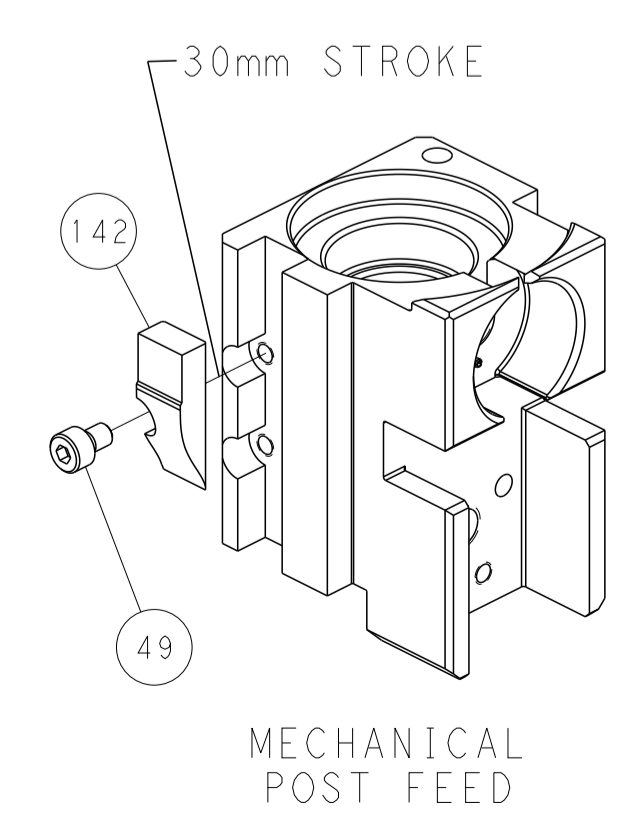

PACIFIC VERSION
 Shown on sheets 3 of 4 & 4 of 4
 (Atlantic version shown on sheets 1 of 4 & 2 of 4)

<small>THIS DRAWING IS UNPUBLISHED. RELEASED FOR PUBLICATION. IT IS THE PROPERTY OF TYCO ELECTRONICS CORPORATION. IT IS TO BE USED ONLY FOR THE PURPOSES AND IN THE QUANTITIES SPECIFIED IN THE ORDER. IT IS NOT TO BE REPRODUCED OR TRANSMITTED IN ANY FORM OR BY ANY MEANS, ELECTRONIC OR MECHANICAL, WITHOUT THE WRITTEN PERMISSION OF TYCO ELECTRONICS CORPORATION.</small>		DMN: HOFFNER CHK: T. ELBIN APVD: T. ELBIN PRODUCT SPEC: APPLICATION SPEC: WEIGHT: MATERIAL:	14AUG2014 15AUG2014 15AUG2014 NAME: SIZE: A1 CAGE CODE: 00779 DRAWING NO: C-2266453 SCALE: 1:2 SHEET: 4 OF 4 REV: C	TE Connectivity Harrisburg, PA 17105-3608 Ocean Side Feed Applicator	RESTRICTED TO:
---	--	---	--	---	----------------