

CODE 40 - BRAID TAIL BACKSHELL



208M916-19B08

SERIES
 DASH NUMBER (TABLE 1)
 MATERIAL
 REFER TO CH00-0250-004
 FINISH
 REFER TO CH00-0250-004 (2)
 ENTRY SIZE (TABLE 2)

NOTES:

1. THIS PRODUCT IS DESIGNED TO TERMINATE A HEAT SHRINKABLE LIPPED BOOT TO A CONNECTOR.
- (2) FOR ADDITIONAL DIMENSIONS, ORDERING INFORMATION AND MODIFICATIONS, SEE CH00-0250-004
3. BACKSHELL TO BE PERMANENTLY MARKED/BAGGED AND LABELLED WITH CODE IDENTIFICATION NUMBER AND PART NUMBER. (e.g. 06090-208M912-19B08).
- (4) WHEN ENTRY SIZE EXCEEDS "MAX ENTRY", A 2 PIECE BACKSHELL (TYPE 2) IS SUPPLIED.
5. BRAID TERMINATION RING MAY BE SUPPLIED AS TINEL-LOCK SHAPE MEMORY RING AT MANUFACTURERS OPTION.
6. BACKSHELL MATES TO MIL-DTL-38999 SERIES III & IV, CLASS C, F, K AND W, D38999/20, /24, /26, /40, /46, /47 CONNECTORS AND WHEN SO MATED SHALL PROVIDE A WATER-TIGHT SEAL MEETING THE REQUIREMENTS OF MIL-C-85049, PAR. 3.5.7.

If this document is printed it becomes uncontrolled. Check for the latest revision

DRAWN	K.WINCZURA	DATE	12/06/2015	 3RD ANGLE PROJECTION NOT TO SCALE	TITLE: BRAID TAIL BACKSHELL	 Polamco  TE <small>connectivity</small>		
CHECKED		12/06/2015						
APPROVED	K.SHEPPARD	10/07/2015	UNLESS OTHERWISE SPECIFIED ALL DIMENSIONS IN MILLIMETRES GENERAL TOL LINEAR +/-0.25MM ANGULAR +/- 1°					
APPROVED	H.SMITH	16/07/2015						
REVISIONS					ASSY USED ON: MIL-DTL-38999 SERIES III & IV			
LTR	DESCRIPTION	DATE	APPROVED					
M	REVISED PER ECO-14-008400	06/04/2014	I.M					
N	REVISED PER ECO-15-010349	16/07/2015	H.SMITH					
TE CAGE CODE: 06090 POLAMCO/TE CAGE CODE: U5792					TE CONNECTIVITY - POLAMCO LTD RESERVES THE RIGHT TO AMEND THIS DRAWING AND THE INFORMATION SET FORTH HEREON AT ANY TIME. USERS SHOULD INDEPENDENTLY EVALUATE THE SUITABILITY OF THE PRODUCT FOR THEIR APPLICATION.	DRAWING NO: 208M9XX	DRAWING REV: N	SHT 1

IF MAX ENTRY IS EXCEEDED BACKSHELL
WILL BE SUPPLIED AS TYPE 2

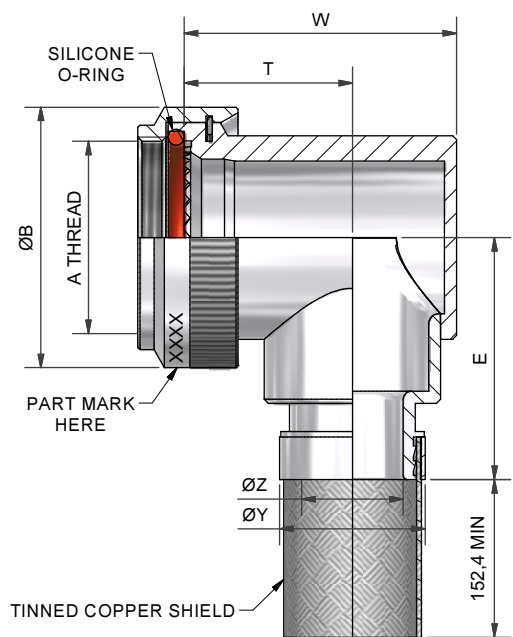

90° BACKSHELL - TYPE 1

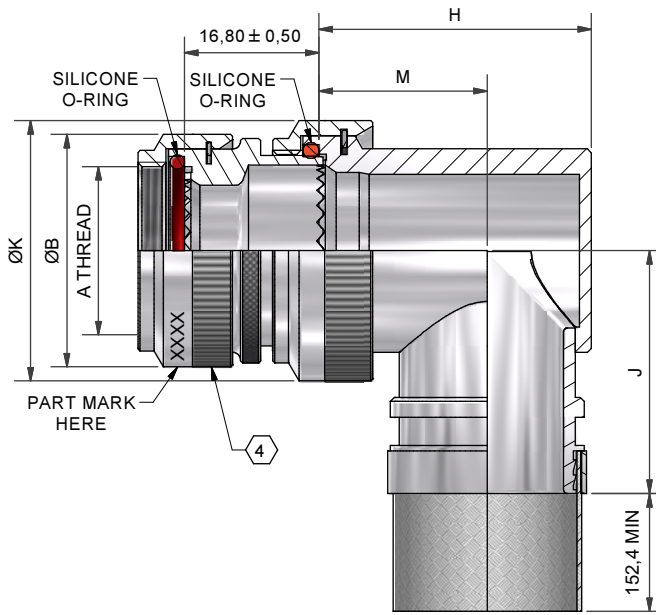

90° BACKSHELL - TYPE 2

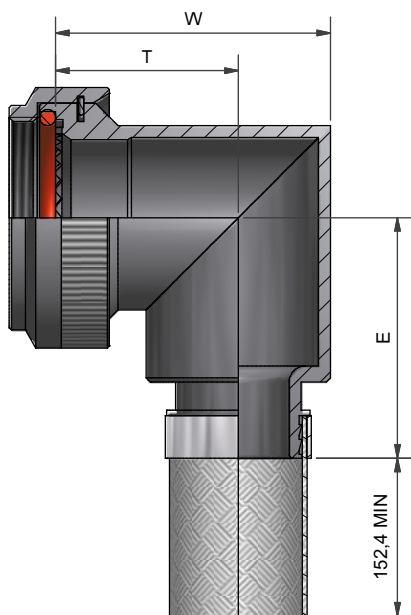

90° BACKSHELL - TYPE 1
STAINLESS STEEL AND
NICKEL ALUMINIUM BRONZE

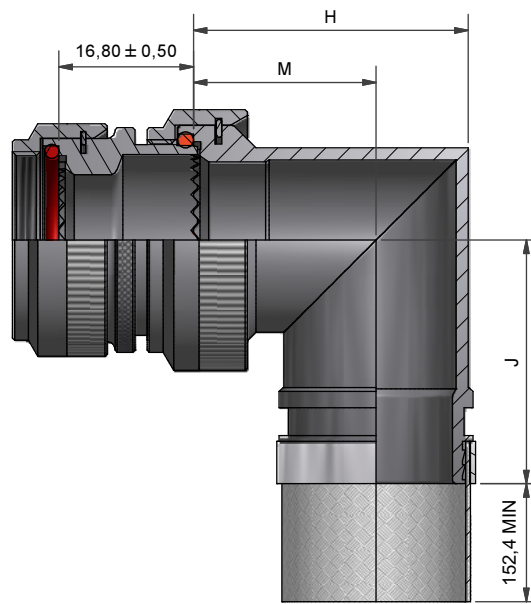

90° BACKSHELL - TYPE 2
STAINLESS STEEL AND
NICKEL ALUMINIUM BRONZE

If this document is printed it becomes uncontrolled. Check for the latest revision

DRAWN	K.WINCZURA	DATE	12/06/2015
CHECKED		DATE	12/06/2015
APPROVED	K.SHEPPARD	DATE	10/07/2015
APPROVED	H.SMITH	DATE	16/07/2015
REVISIONS			
LTR	DESCRIPTION	DATE	APPROVED
M	REVISED PER ECO-14-008400	06/04/2014	I.M
N	REVISED PER ECO-15-010349	16/07/2015	H.SMITH



3RD ANGLE
PROJECTION
NOT TO
SCALE

UNLESS OTHERWISE SPECIFIED
ALL DIMENSIONS IN MILLIMETRES
GENERAL TOL
LINEAR +/-0.25MM
ANGULAR +/- 1°

TITLE:

BRAID TAIL BACKSHELL

ASSY USED ON:

MIL-DTL-38999 SERIES III & IV



TE CAGE CODE: 06090
POLAMCO/TE CAGE CODE: U5792

TE CONNECTIVITY - POLAMCO LTD RESERVES THE RIGHT TO AMEND THIS DRAWING
AND THE INFORMATION SET FORTH HEREON AT ANY TIME. USERS SHOULD
INDEPENDENTLY EVALUATE THE SUITABILITY OF THE PRODUCT FOR THEIR APPLICATION.

DRAWING NO:
208M9XX

DRAWING REV:
N

SHT
2



TABLE 1

ORDER NUMBER	SHELL SIZE COM'L / MIL	A THREAD	ØB MAX	MAX ENTRY	W ±0,5	T ±0,5	E ±0,5	THESE DIMENSIONS APPLY IF BACKSHELL IS STAINLESS STEEL OR NICKEL ALUMINIUM BRONZE		
								W ±0,5	T ±0,5	E ±0,5
208M908	9 / A	M12x1.0	18,0	04	21,0	14,0	24,0	21,2	16,3	24,0
208M910	11 / B	M15x1.0	21,0	07	24,0	15,5	25,7	24,3	17,2	25,7
208M912	13 / C	M18x1.0	24,5	09	27,0	17,0	27,2	28,3	19,4	27,2
208M914	15 / D	M22x1.0	29,0	10	31,0	19,5	28,7	31,1	21,0	28,7
208M916	17 / E	M25x1.0	32,5	12	34,0	21,0	30,4	34,2	22,8	30,4
208M918	19 / F	M28x1.0	35,5	14	35,0	20,0	32,0	38,5	25,3	32,0
208M920	21 / G	M31x1.0	37,0	16	38,0	21,5	33,6	40,7	26,1	33,6
208M922	23 / H	M34x1.0	40,0	18	42,0	24,0	35,1	43,7	27,6	35,1
208M924	25 / J	M37x1.0	43,5	20	45,0	25,5	36,6	46,4	29,1	36,6

TABLE 2

ENTRY SIZE	ØK MAX	ØZ REF	ØY REF	H ±0,5	M ±0,5	J ±0,5	THESE DIMENSIONS APPLY IF BACKSHELL IS STAINLESS STEEL OR NICKEL ALUMINIUM BRONZE		
							H ±0,5	M ±0,5	J ±0,5
03	NA	4,77	13,1	NA	NA	NA	NA	NA	NA
04	NA	6,35	13,1	NA	NA	NA	NA	NA	NA
05	21,0	7,92	13,1	24,0	15,5	25,7	24,3	17,2	25,7
06	21,0	9,52	17,9	24,0	15,5	25,7	24,3	17,2	25,7
07	21,0	11,12	17,9	24,0	15,5	25,7	24,3	17,2	25,7
08	24,5	12,70	17,9	27,0	17,0	27,2	28,3	19,4	27,2
09	24,5	14,27	17,9	27,0	17,0	27,2	28,3	19,4	27,2
10	29,0	15,87	24,2	31,0	19,5	28,7	31,1	21,0	28,7
11	32,5	17,47	24,2	34,0	21,0	30,4	34,2	22,8	30,4
12	32,5	19,05	24,2	34,0	21,0	30,4	34,2	22,8	30,4
13	35,5	20,62	24,2	35,0	20,0	32,1	38,5	25,3	32,1
14	35,5	22,23	30,6	35,0	20,0	32,1	38,5	25,3	32,1
15	37,0	23,82	30,6	38,0	21,5	33,7	40,7	26,1	33,7
16	37,0	25,40	30,6	38,0	21,5	33,7	40,7	26,1	33,7
17	40,0	26,98	33,2	42,0	24,0	35,2	43,7	27,6	35,2
18	40,0	28,60	33,2	42,0	24,0	35,2	43,7	27,6	35,2
20	43,5	31,80	42,0	45,0	25,5	36,7	46,4	29,1	36,7
21	48,5	33,34	42,0	54,5	31,0	39,8	50,0	31,0	39,8
22	48,5	35,00	42,0	54,5	31,0	39,8	50,0	31,0	39,8
24	52,1	38,10	42,0	58,0	33,0	43,8	53,5	33,0	43,8
28	58,5	44,45	49,0	65,5	36,5	48,9	60,3	36,5	48,9

If this document is printed it becomes uncontrolled. Check for the latest revision

DRAWN	K.WINCZURA	DATE	12/06/2015	 3RD ANGLE PROJECTION NOT TO SCALE	TITLE: BRAID TAIL BACKSHELL	 Polamco
CHECKED		DATE	12/06/2015			
APPROVED	K.SHEPPARD	DATE	10/07/2015			
APPROVED	H.SMITH	DATE	16/07/2015			
UNLESS OTHERWISE SPECIFIED ALL DIMENSIONS IN MILLIMETRES GENERAL TOL LINEAR +/-0,25MM ANGULAR +/- 1°					ASSY USED ON: MIL-DTL-38999 SERIES III & IV	 TE connectivity
REVISIONS						
LTR	DESCRIPTION	DATE	APPROVED			
M	REVISED PER ECO-14-008400	06/04/2014	I.M			
N	REVISED PER ECO-15-010349	16/07/2015	H.SMITH			
TE CAGE CODE: 06090 POLAMCO/TE CAGE CODE: U5792					TE CONNECTIVITY - POLAMCO LTD RESERVES THE RIGHT TO AMEND THIS DRAWING AND THE INFORMATION SET FORTH HEREON AT ANY TIME. USERS SHOULD INDEPENDENTLY EVALUATE THE SUITABILITY OF THE PRODUCT FOR THEIR APPLICATION.	DRAWING NO: 208M9XX
					DRAWING REV: N	
					SHT 3	