

POWER MANAGEMENT

Description

The SC4201 is a multi-phase link controller, ideal for isolated and non-isolated applications. Its frequency of operation can be programmed in excess of 2MHz per phase (oscillator frequency = phase frequency times number of phases 3 or 4) and can be easily synchronized to an external faster frequency. The SC4201 output frequencies can be set to 2/4 or 3 phase operation. A single pin can either set a 4 phase operation (each phase is 90 degrees apart) or 3 phase operation (120 degrees apart).

Multi-phase operation of multiple primary or secondary controllers reduces input/output ripple, the number of components required for filtering, and noise due to frequency beating generated by multiple free running oscillators.

The SC4201 is available in the MSOP-8 surface mount package.

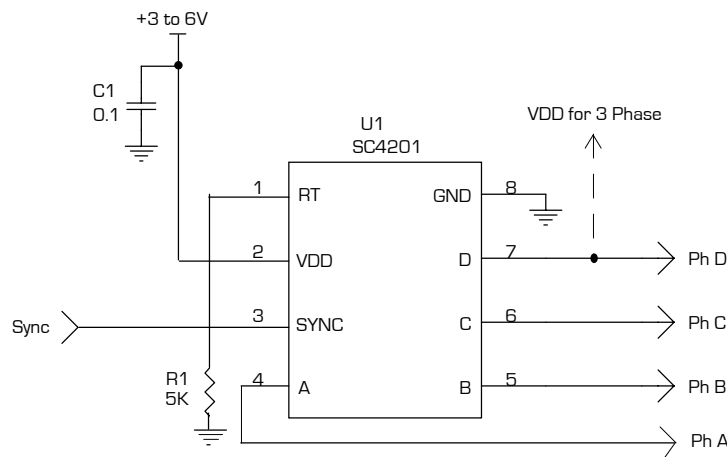
Features

- ◆ Small footprint MSOP-8
- ◆ Programmable frequency > 2MHz, each phase
- ◆ Synchronized to faster frequency
- ◆ Programmable 2/4 or 3 phase operation

Applications

- ◆ Telecom distributed power architectures
- ◆ Multi-phase operation of isolated power supplies
- ◆ Multi-phase operation of non-isolated switching regulators

Typical Application Circuit



POWER MANAGEMENT
Absolute Maximum Ratings

Exceeding the specifications below may result in permanent damage to the device, or device malfunction. Operation outside of the parameters specified in the Electrical Characteristics section is not implied.

Parameter	Symbol	Limits	Units
Supply Voltage	V_{IN}	7	V
RT, SYNC	V_{P_K}	-0.3V to V_{DD} +0.3	V
Operating Ambient Temperature Range	T_A	-40 to +125	°C
Junction Temperature Range	T_J	-40 to 150	°C
Storage Temperature Range	T_{STG}	-65 to 150	°C
Lead Temperature (Soldering) 10 sec	T_{LEAD}	+300	°C
Thermal Impedance Junction to Ambient	θ_{JA}	206	°C/W
ESD Rating (Human Body Model)	ESD	2	kV

Electrical Characteristics

Unless specified: $T_A = T_J = -40$ to $+125^\circ\text{C}$, $V_{DD} = 5\text{V}$, $R_T = 100\text{K}$, 4-phase.

Parameter	Symbol	Conditions	Min	Typ	Max	Units
Supply Voltage, Operating	V_{DD}		3.0		6.0	V
Supply Current	I_{DD}	$V_{DD} = 6\text{V}$, $R_T = 36.5\text{k}\Omega$, $C_{OUT} = 20\text{pF}$		2.35	2.60	mA
VDD Start Threshold					3.10	V
VDD UVLO Hysteresis			70	100	130	mV
Output Frequency, per phase	F_{OUT}	See graphs, Fig 2 - 5	0.1		2	MHz
Output Frequency Stability		$V_{DD} = 3\text{V}$ to 6V			10	%
Phase Accuracy		By design, not tested			1	%
Sync Input Threshold	V_{SYNC}	See pin description		$V_{DD}/3$		V
O/P Rise Time	T_R	$C_{OUT} = 20\text{pF}$, $V_{DD} = 3\text{V}$ to 6V		10		ns
O/P Fall Time	T_F	$C_{OUT} = 20\text{pF}$, $V_{DD} = 3\text{V}$ to 6V		10		ns
Output Voltage	V_{OUT}				V_{DD}	V
Output Current (peak)	I_{OUT}	$V_{DD} = 5\text{V}$		25		mA
		$V_{DD} = 3.3\text{V}$		10		
Output Impedance	R_{OUT}			60		Ω
Output Duration	T_P			(1)		ns

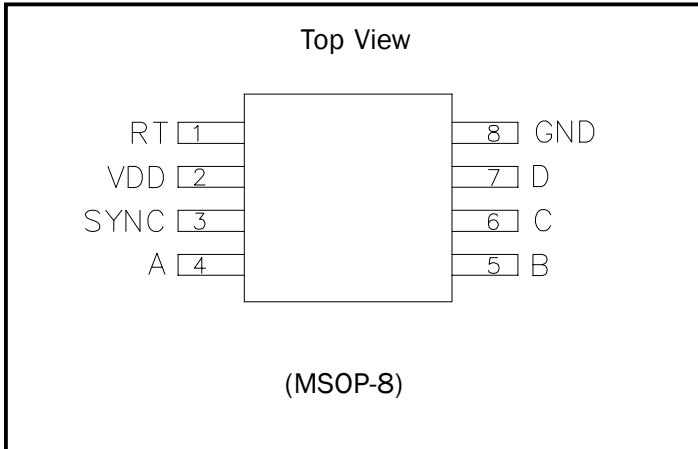
Note:

$$(1) T_P = \frac{T_{OUT}}{N} \text{ where } T_{OUT} = \text{output signal period of individual phase.}$$

$N = 3$ for 3 phase operation, $N = 4$ for 2/4 phase operation.

POWER MANAGEMENT

Pin Configuration



Ordering Information

Part Number ⁽¹⁾	Package
SC4201MSTRT ⁽²⁾	MSOP-8
SC4201EVB	Evaluation Board

Notes:

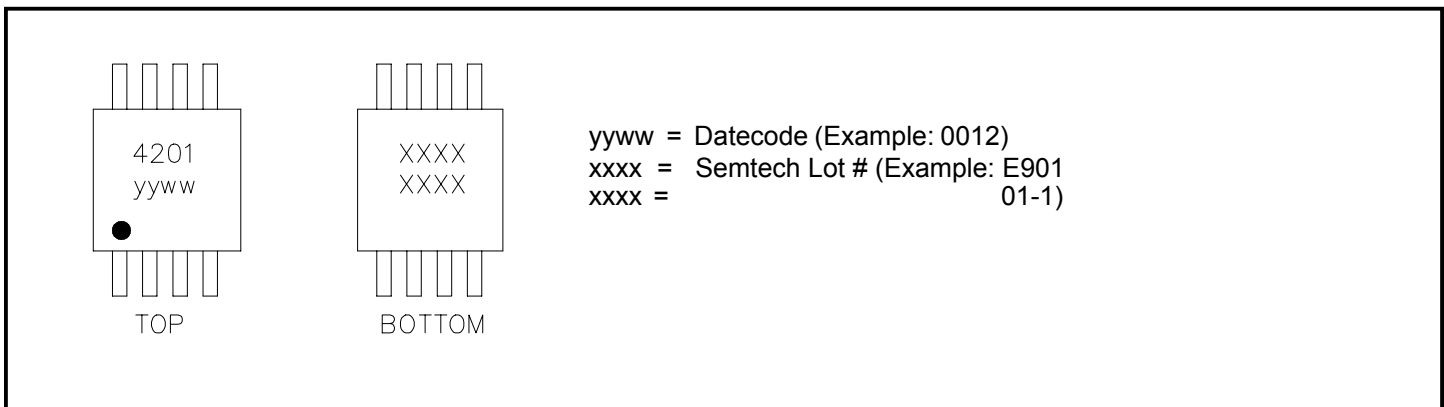
(1) Only available in tape and reel packaging. A reel contains 2500 devices.

(2) Lead free product. This product is fully WEEE and RoHS compliant.

Pin Descriptions

Pin	Pin Name	Pin Function
1	RT	Oscillator frequency is configured by connecting resistor R from RT to ground. Values for R can be selected to provide desired 3 phase or 4 phase output frequencies.
2	VDD	The power input connection for the device.
3	SYNC	SYNC is a positive edge triggered input with a threshold of $\sim V_{DD}/3$. SYNC should be grounded when not required or connected to an external synchronization clock with frequency higher than the on board oscillator frequency (with respect to internal clock). SYNC frequency = phase frequency times number of phases 3 or 4.
4	A	Logic level output clock. Phase "A", totem-pole type.
5	B	Logic level output clock. Phase "B", totem-pole type.
6	C	Logic level output clock. Phase "C", totem-pole type.
7	D	Logic level output, totem-pole type, lock and phase selection pin. Default operation 4 phase/2 phase (90°/180°). Tie D to VDD to select 3 phase operation through A, B and C 120° out of phase.
8	GND	Reference ground and power ground for all functions.

Marking Information



POWER MANAGEMENT

Block Diagram

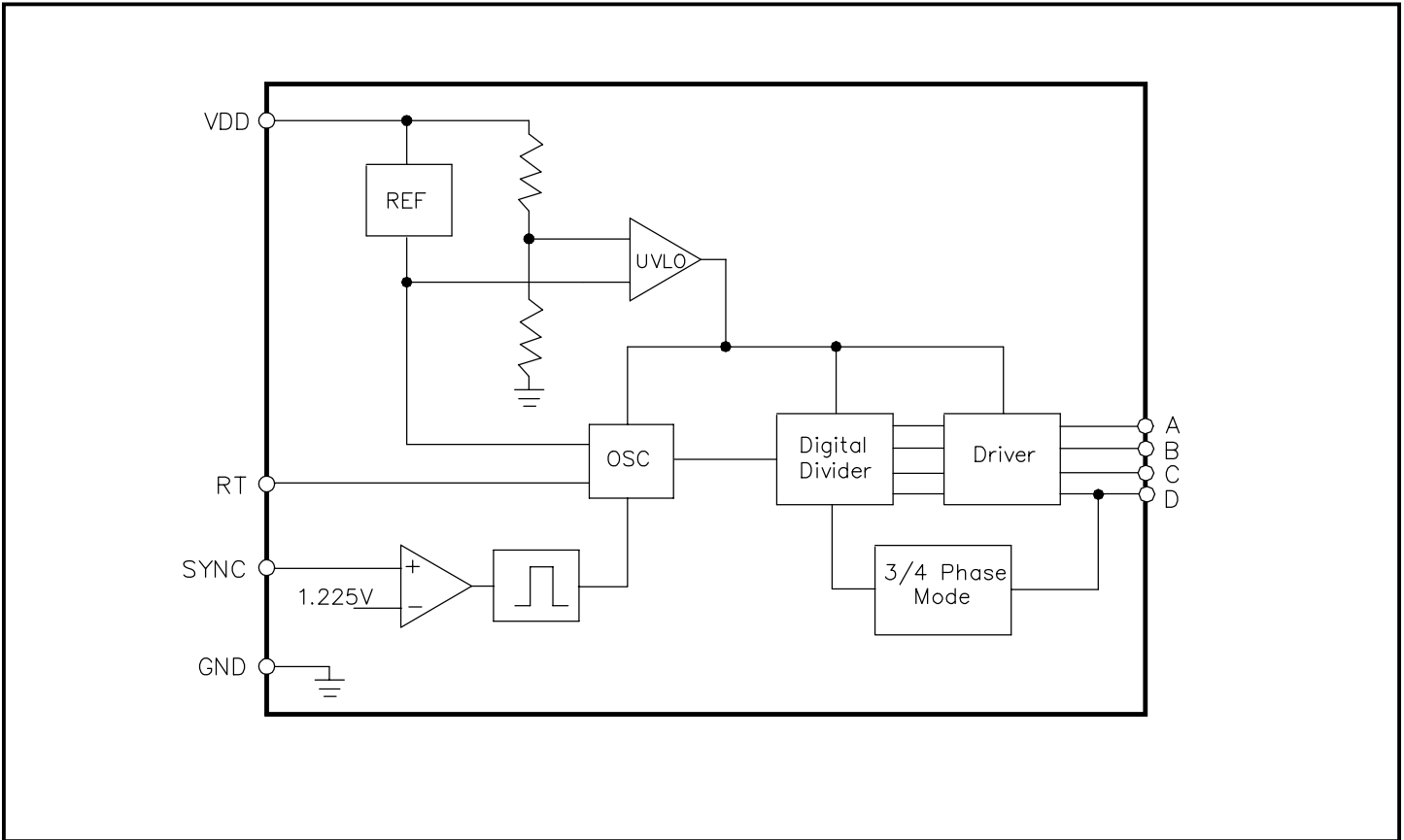
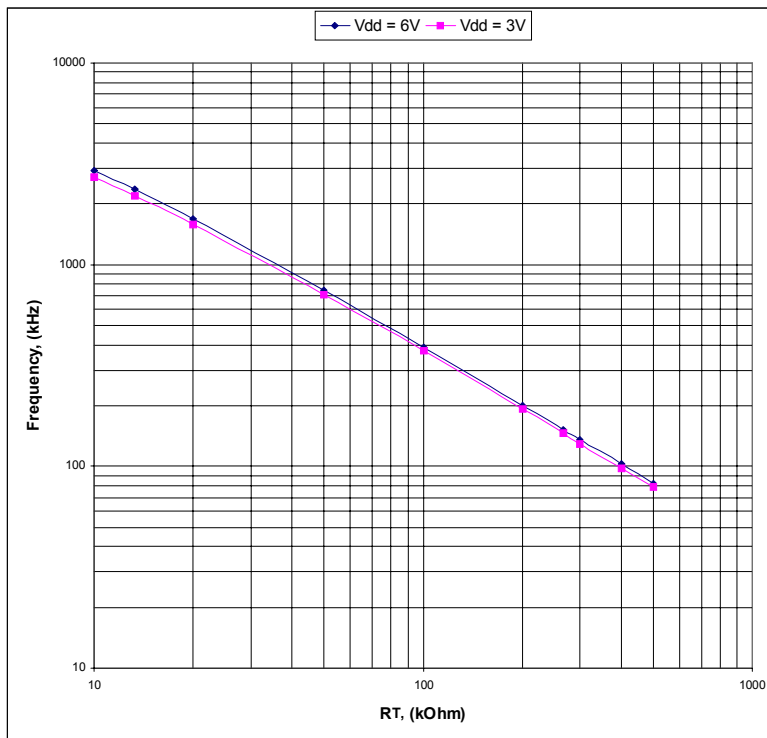
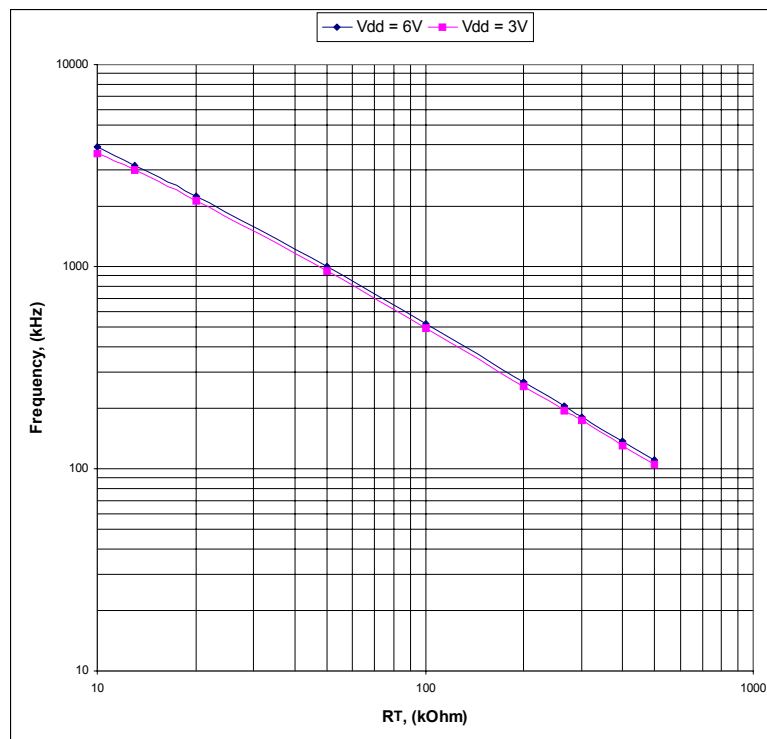
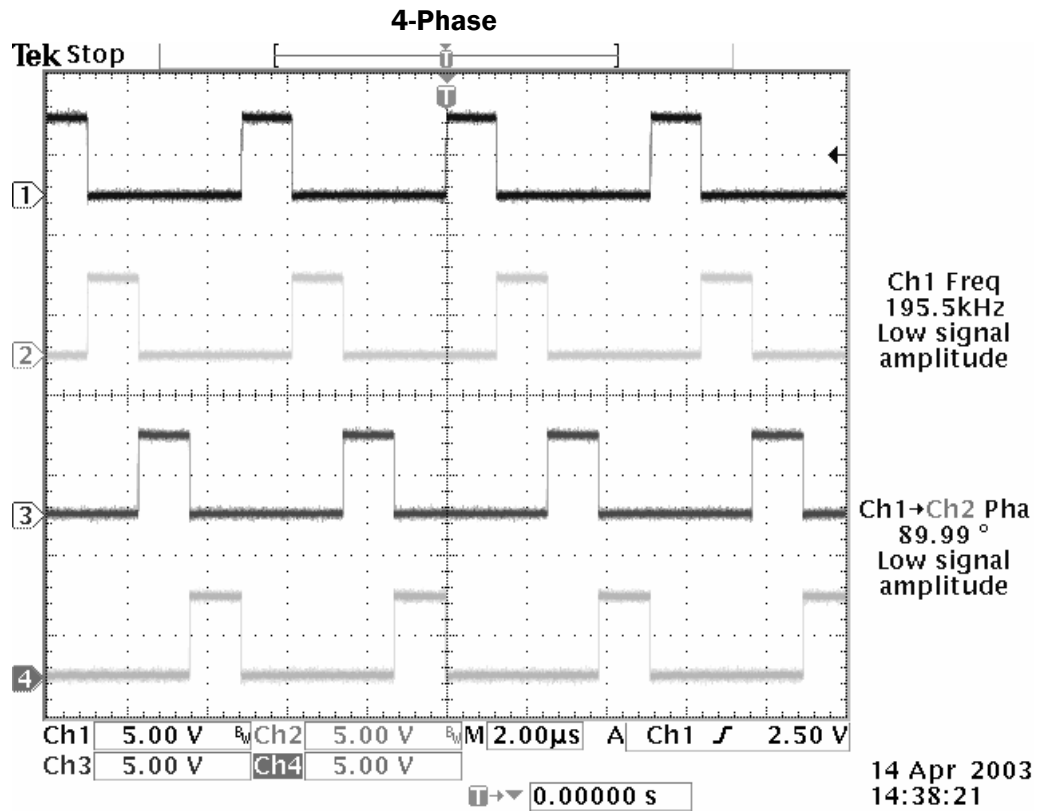
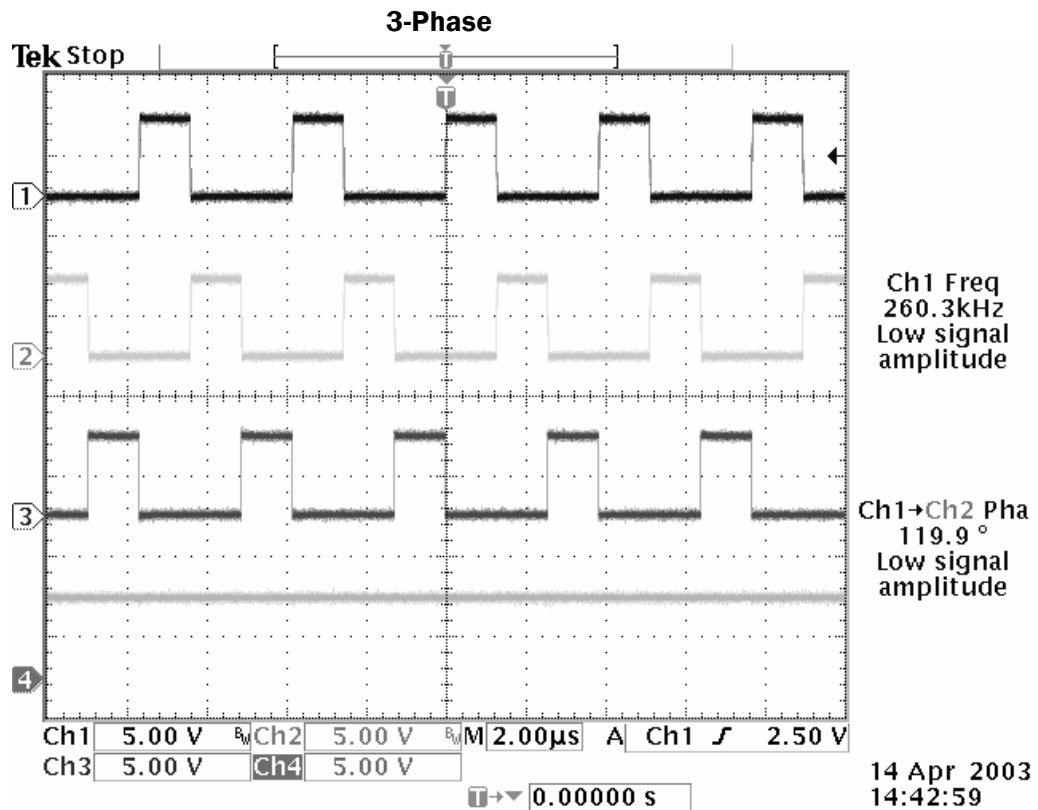


Figure 1

Phase Frequency vs. R_T , 4-Phase Operation

Figure 2
Phase Frequency vs. R_T , 3-Phase Operation

Figure 3


Figure 4

Figure 5

POWER MANAGEMENT
Application Information

Diagram in Figure 6 shows multi-phase operation of several power converters with fixed switching frequency FSW.

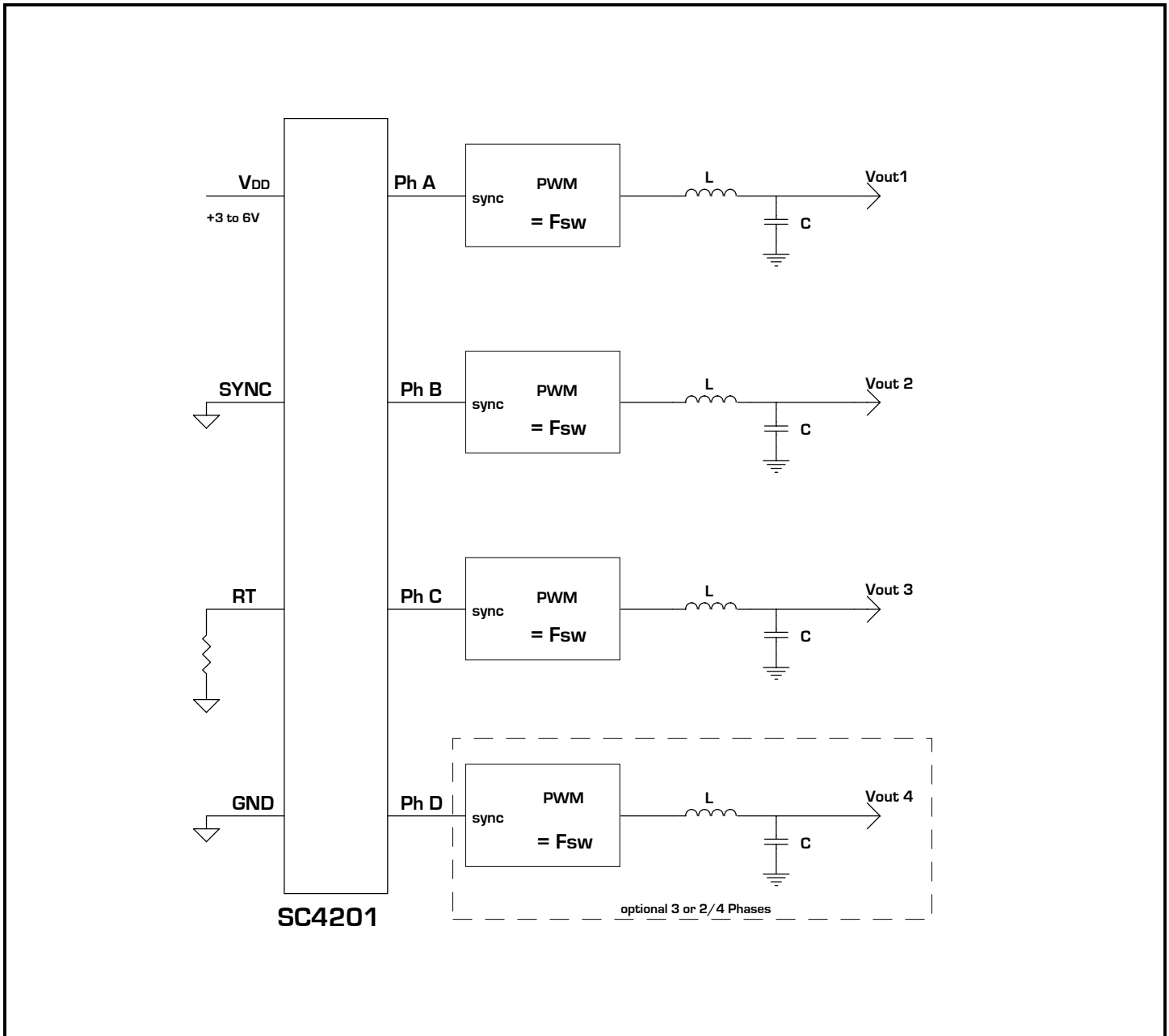
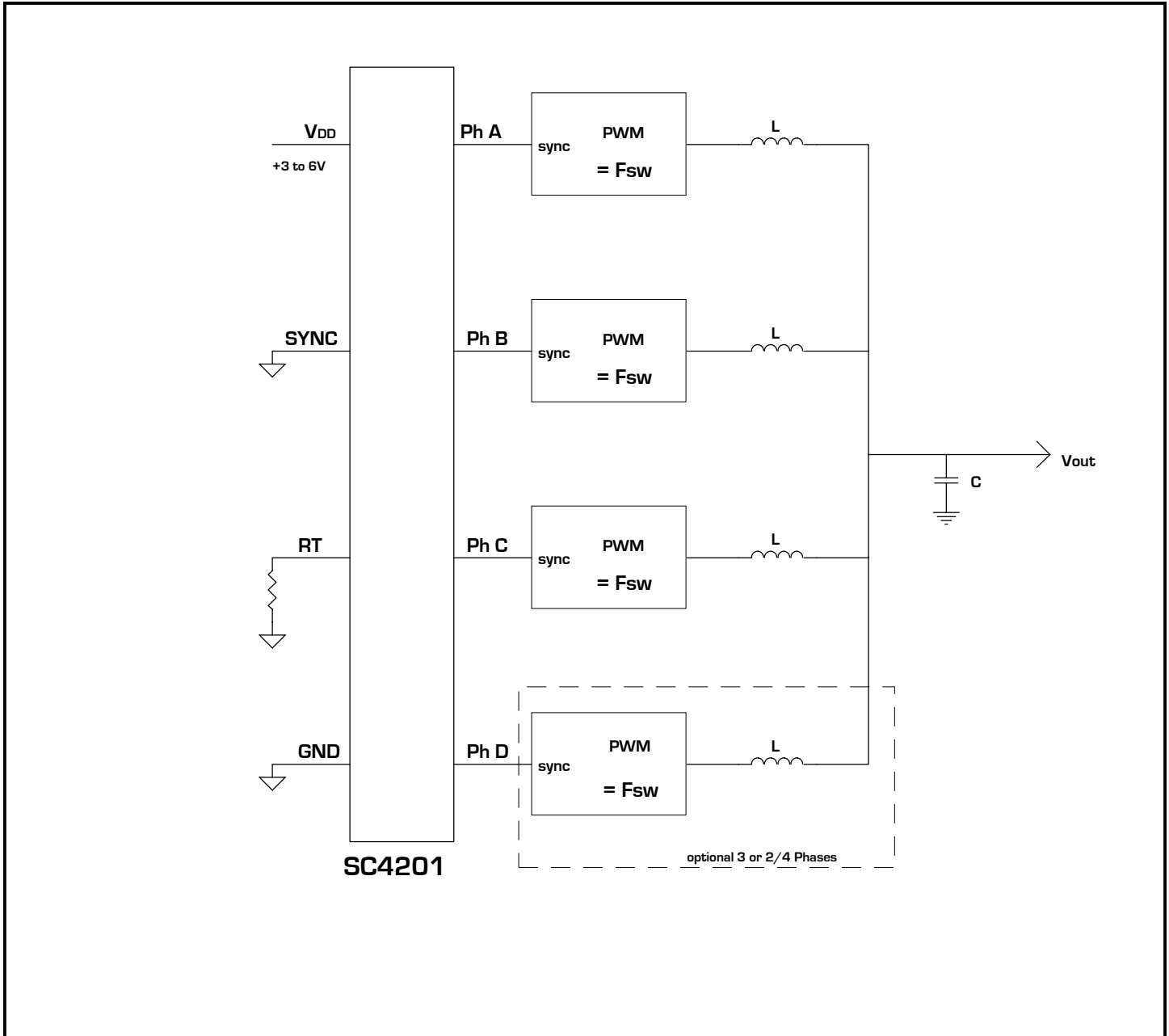


Figure 6

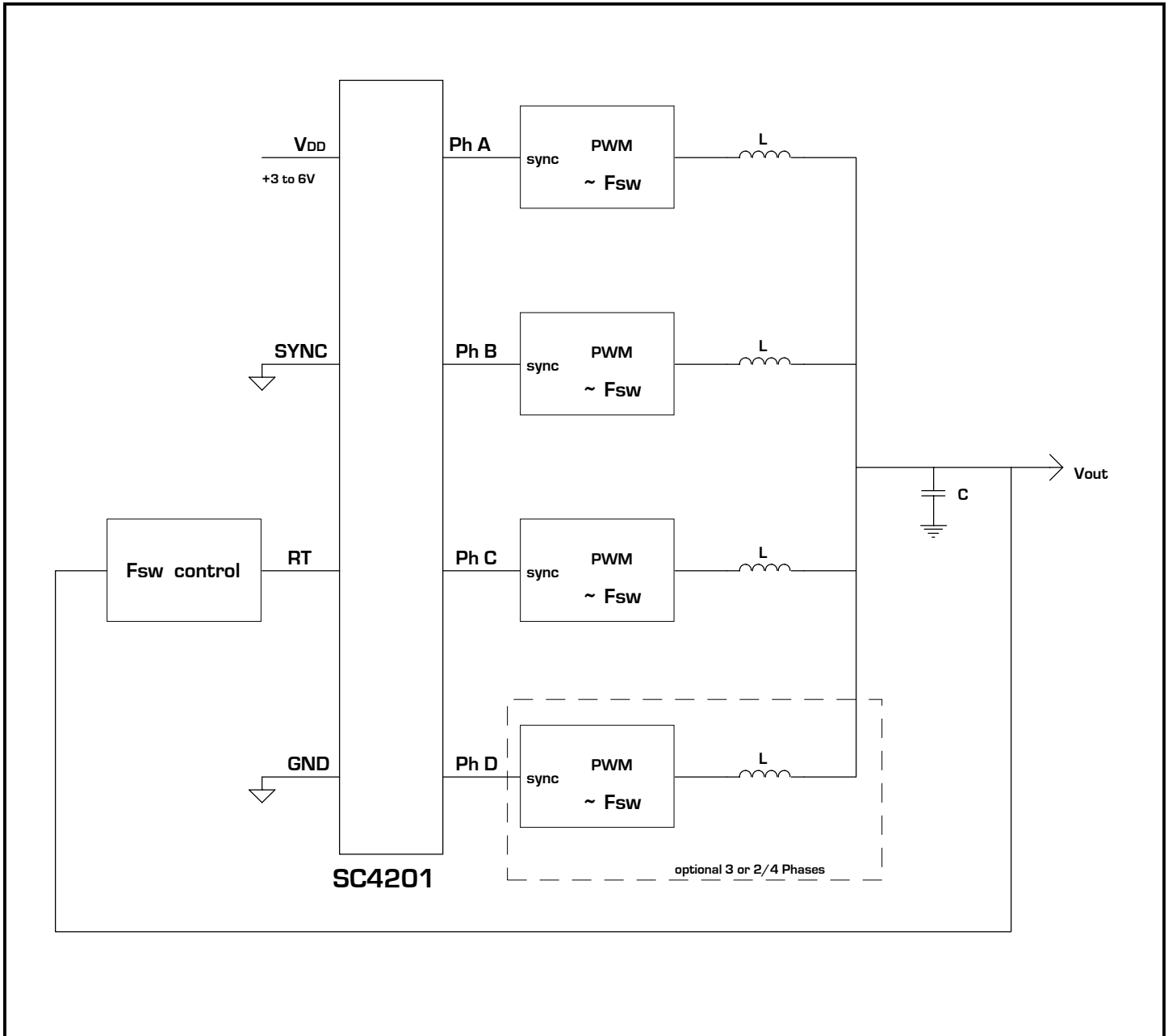
POWER MANAGEMENT
Application Information (Cont.)

Diagram in Figure 7 demonstrates a multi-phase operation of a single power supply with current sharing through the individual phases and with fixed switching frequency FSW.


Figure 7

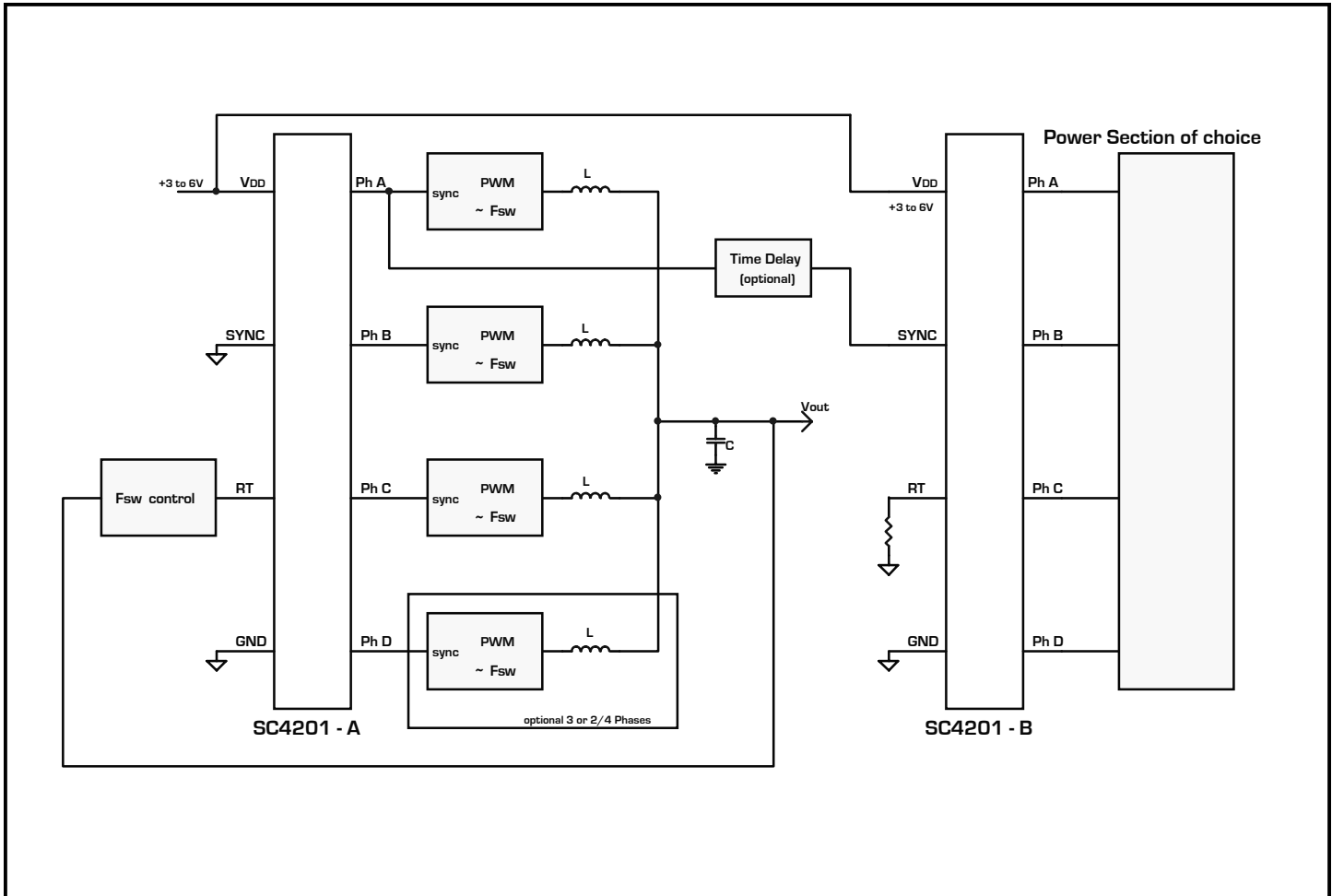
POWER MANAGEMENT
Application Information (Cont.)

Diagram in Figure 8 assumes variable switching frequency FSW, e.g. resonant power converters. This circuit will require additional "FSW Control" block, which is a task for a power designer.


Figure 8

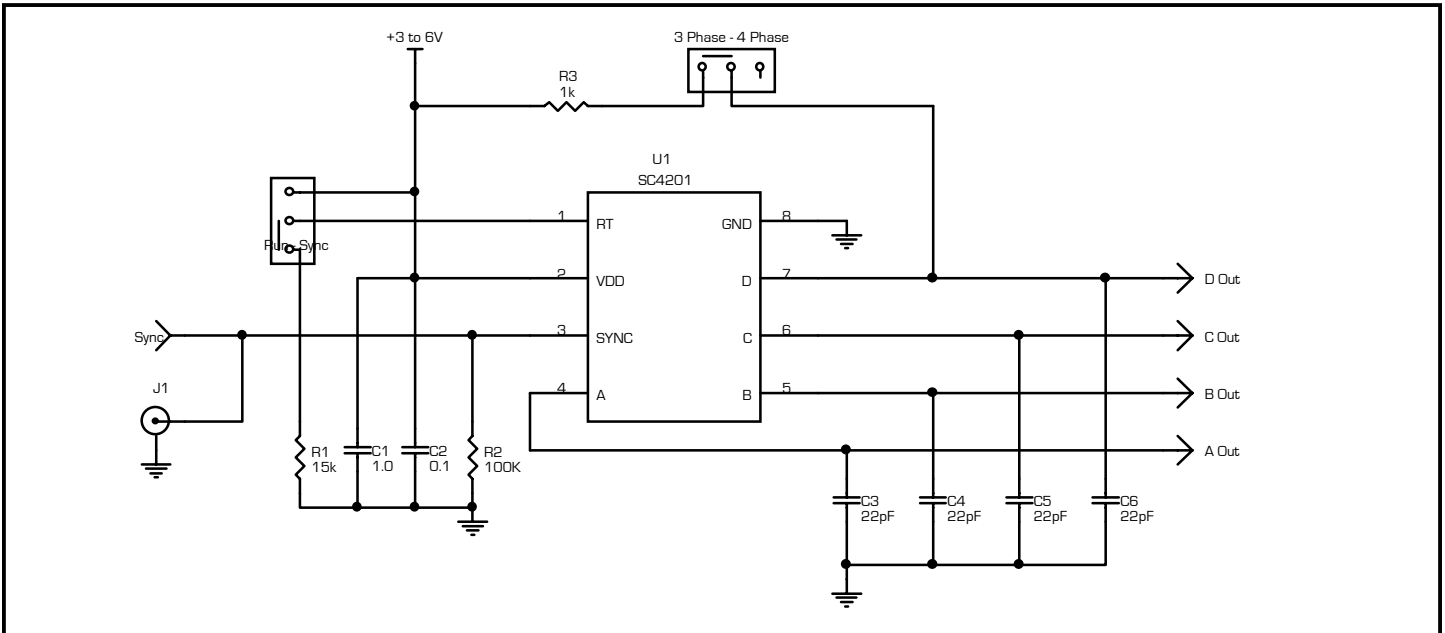
POWER MANAGEMENT
Application Information (Cont.)

Diagram in Figure 9 demonstrates a synchronous operation of two (or more) SC4201 controllers. If the “time delay” circuit is to be employed then 6-phase, 8-phase and other configurations become possible.

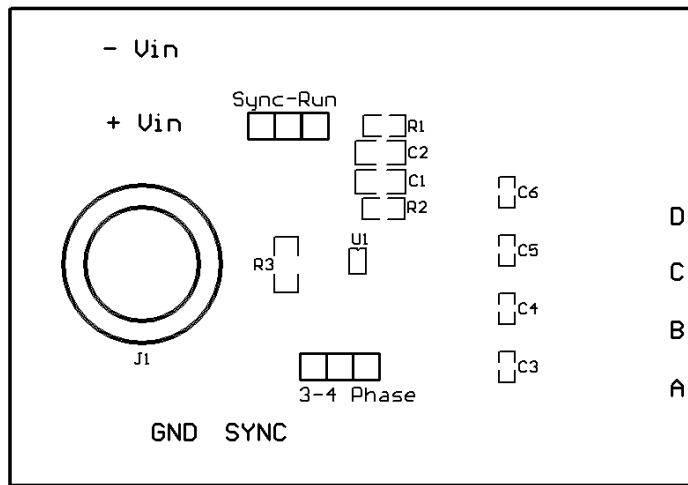

Figure 9

POWER MANAGEMENT

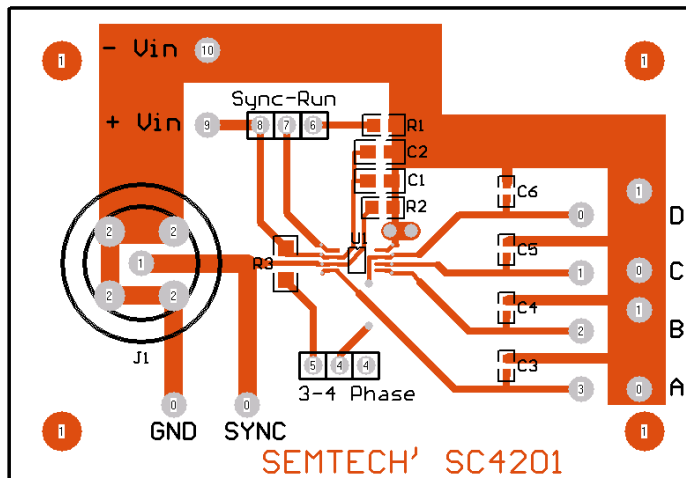
Evaluation Board Schematic



Top View

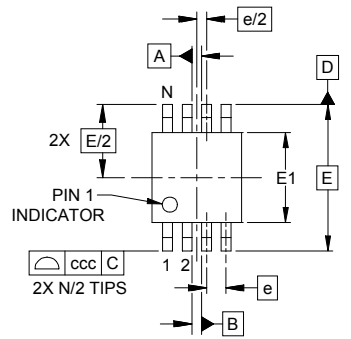


Layout

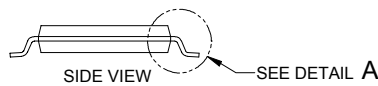
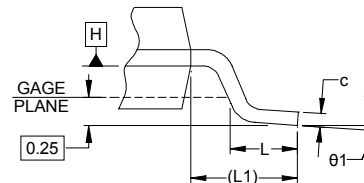
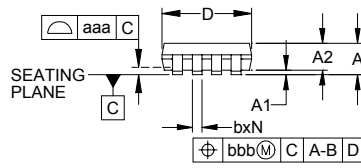


POWER MANAGEMENT

Outline Drawing - MSOP-8



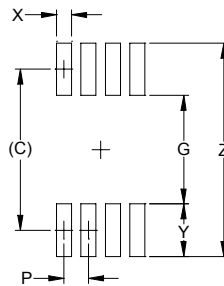
DIM	INCHES			MILLIMETERS		
	MIN	NOM	MAX	MIN	NOM	MAX
A	-	-	.043	-	-	1.10
A1	.000	-	.006	0.00	-	0.15
A2	.030	-	.037	0.75	-	0.95
b	.009	-	.015	0.22	-	0.38
c	.003	-	.009	0.08	-	0.23
D	.114	.118	.122	2.90	3.00	3.10
E1	.114	.118	.122	2.90	3.00	3.10
E	.193 BSC			4.90 BSC		
e	.026 BSC			0.65 BSC		
L	.016	.024	.032	0.40	0.60	0.80
L1	(.037)			(.95)		
N	8			8		
θ1	0°	-	8°	0°	-	8°
aaa	.004			0.10		
bbb	.005			0.13		
ccc	.010			0.25		



NOTES:

1. CONTROLLING DIMENSIONS ARE IN MILLIMETERS (ANGLES IN DEGREES).
2. DATUMS $\boxed{-A-}$ AND $\boxed{-B-}$ TO BE DETERMINED AT DATUM PLANE $\boxed{-H-}$
3. DIMENSIONS "E1" AND "D" DO NOT INCLUDE MOLD FLASH, PROTRUSIONS OR GATE BURRS.
4. REFERENCE JEDEC STD MO-187, VARIATION AA.

Land Pattern - MSOP-8



DIM	DIMENSIONS	
	INCHES	MILLIMETERS
C	(.161)	(4.10)
G	.098	2.50
P	.026	0.65
X	.016	0.40
Y	.063	1.60
Z	.224	5.70

NOTES:

1. THIS LAND PATTERN IS FOR REFERENCE PURPOSES ONLY. CONSULT YOUR MANUFACTURING GROUP TO ENSURE YOUR COMPANY'S MANUFACTURING GUIDELINES ARE MET.

Contact Information

Semtech Corporation
 Power Management Products Division
 200 Flynn Road, Camarillo, CA 93012
 Phone: (805)498-2111 FAX (805)498-3804