

DC centrifugal fan *RV45*

Remarkably quiet and powerful

ebmpapst

the engineer's choice



Top performer *from a top supplier.*

Six things that make us the ideal partner:

Our systems expertise: As experts in advanced motor technology, electronics and aerodynamics, we provide ideal system solutions from a single source.

The ebm-papst spirit of invention: Our 600 engineers and technicians will develop a solution that precisely suits your needs.

Our lead in technology: With our GreenTech EC technology, we set new standards worldwide. And our lead is your competitive advantage.

Proximity to our customers: At 49 sales offices worldwide.

Our standard of quality: Our quality management is uncompromising, at every step in every process.

Our sustainable approach: We assume responsibility with our energy-saving products, environmentally friendly processes, and social commitment.

Dynamic air delivery for demanding applications.

Fans used in the medical sector – for example in sleep apnea breathing devices – have to meet particularly high standards with regard to dynamics, smooth operation, reliability, acoustics and compactness.

The ebm-papst centrifugal fan RV45 passes every test with flying colors: Its extremely dynamic EC internal rotor motor supports flexible adaptation to the breathing sequence and switches both quickly and reliably between a high inflation pressure (inhalation) and a considerably lower pressure for unobstructed exhalation. The high speed of up to 50,000 rpm produces exactly the power required, assisted by the low moment of inertia of the rotor. Vibration absorbing materials and ideal aerodynamics ensure particularly quiet operation – over a period of many years thanks to maintenance-free ball bearings.

Having been designed for external control, users can employ their own systems or work with the ebm-papst "RV45 power module", which enables the RV45 to be used in a wide range of industrial sectors as well.

With its big performance and all features designed into a 64 x 69.5 x 54.5 mm package smaller than a tennis ball, the RV45 is the ideal solution for any number of demanding tasks. These are found not only in the medical sector but also for industrial applications such as fuel cells, smoke detectors or packaging machines.



You don't have to be big to be a great performer.

Breathing device applications demand fans with highly dynamic characteristics. A high pressure is required at the start of the breathing sequence and a low pressure at the end. In practice, that means pressure fluctuations between 400 Pa and 2000 Pa. With a centrifugal impeller, the flow quantity and delivery pressure increase with increasing speed. The high nominal speed of 40,000 rpm thus produces dynamic power output – with a compact design.

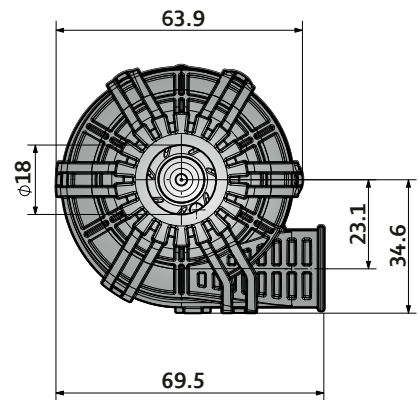
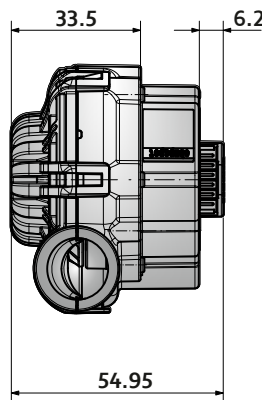
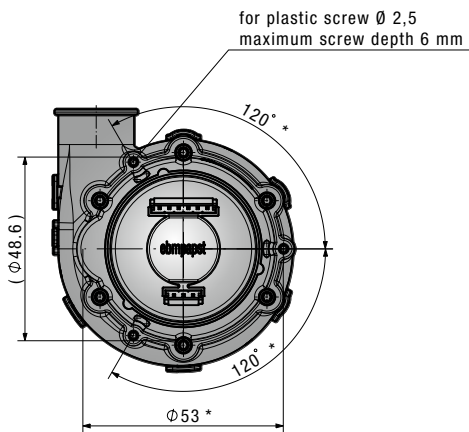
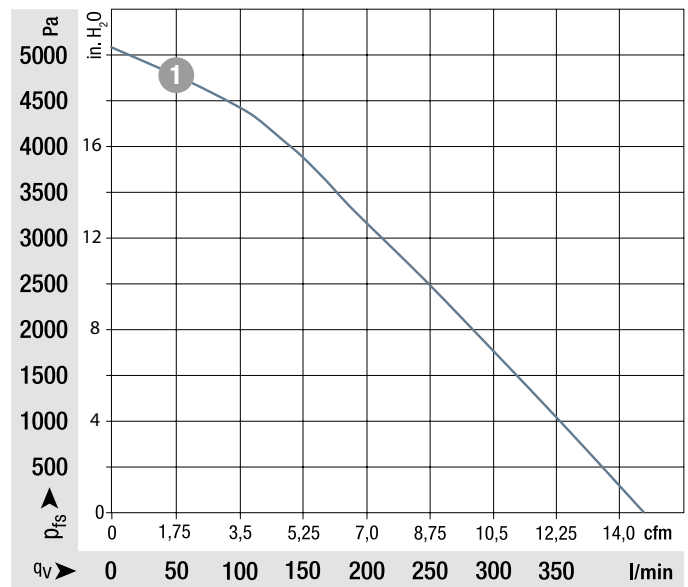

Nominal data		Air flow	Air flow	Nominal voltage	Voltage range *	Sound pressure **	with Hall sensors without Hall sensors	Power consumption	Nominal speed	Temperature range	Service life L_{10} (20°C) ebm-papst standard	Service life L_{10} (T_{max}) ebm-papst standard	Life expectancy L_{30} IPC (25°C)	Characteristic curve
Type	Item number	l/min	cfm	VDC ⁻¹	VDC	dB(A)	■ □	W	rpm	°C	Hours	Hours		
RV45-3/14	9593505001	410	14.5	24	7...30	49	■	43	40,000	-20...+70	22,500/7,500	50,000	①	
RV45-3/14S	9593505002	410	14.5	24	7...30	49	□	43	40,000	-20...+70	22,500/7,500	50,000	①	

* Depending on the customer's actuation electronics.

** Measured at 1,000 Pa and a distance of 1 m above the intake side.

Blower with hose and standard resistor with 4 mm inside diameter, a length of 40 mm and a 45° outlet angle.

All dimensions in mm. Data sheets available on request. The product descriptions in this brochure do not represent assured properties.

So many strengths in such little space.

Motor

- + **Unrivaled compactness**
 - Very compact thanks to new motor design
 - Special high-performance magnets
- + **Highly dynamic and efficient operation**
 - Lightweight rotor for highly dynamic operation
 - Acceleration: up to 100 rev/ms
 - Suitable for BIPAP and AutoCPAP/APAP
- + **Low noise emissions**
 - Quiet-running, just 49 dB(A)
- + **Minimal vibration**
 - Dynamic balancing of the impeller-motor unit



Air outlet

- + **Simple connection**
 - Universal air outlet simplifies incorporation into the application
 - Can be connected to rubber collar or medical tube with clip



The advantages at a glance:

- Quiet-running: Exemplary noise level of just 49 dB(A)
- Very dynamic and top performance: Up to 100 rev/ms with static pressure increase of over 5,000 Pa.
- Intelligent design: Highly compact outer dimensions and weighs only 135 grams (4.8 oz)

Actual size



Connection area

- + **Simple commissioning**
 - Integrated plug-in system
 - High-grade JST connectors
 - Additional external operating electronics required for sensorless commutation: "RV45 power module"
- + **Optional:** Wire set (310 mm length) available as adapter for own connection



More information? No problem:

For technical queries please contact our expert Martin Sauter on +49 7724 811144 or send an e-mail to martin.sauter@de.ebmpapst.com

Integrated sensors

- + **Possible custom designs**
 - Hall sensors
 - Internal temperature sensor (NTC)



Impeller

- + **High static efficiency**
 - Aerodynamically optimized blade geometry
- + **Lightweight**
 - For highly dynamic operation
- + **Low losses**
 - Optimum fan impeller inflow and low noise level
- + **Robust design**
 - Designed for speeds up to 50,000 rpm and extreme pressures



Scroll housing

- + **Robust design**
 - Scroll housing for reduced noise
 - FDA-listed materials: physiologically safe, ideal for human use
- + **Simple installation**
 - Mounting holes for simple screw attachment



ebmpapst

the engineer's choice

ebm-papst
St. Georgen GmbH & Co. KG

Hermann-Papst-Straße 1
78112 St. Georgen
Germany
Phone +49 7724 81-0
Fax +49 7724 81-1309
info2@de.ebmpapst.com