

**NOTES:**

- 1. MATERIALS: "G" STYLE**
  - 1.1 SHELL, FERRULE  
BRASS PER QQ-B-626  
FINISH: GOLD, OVER  
ELECTROLESS NICKEL  
PER MIL-G-45204, TYP 2, CLASS 1
  - 1.2 INSERT  
PEEK, GLASS FILLED PER  
MIL-P-46183
  - 1.3 CONTACTS  
COPPER ALLOY  
FINISH: GOLD PER MIL-G-45204
  - 1.4 GASKETS (OPTIONAL)  
SILICONE RUBBER PER AMS 3304
  - 1.5 ALTERNATE SHELL MATERIALS  
AND FINISHES:  
"M" STYLE: BRASS, WITH  
ELECTROLESS NICKEL FINISH  
PER AMS-C-26074, CLASS 4, GRADE B  
"A" STYLE: BRASS, WITH GOLD PLATE,  
BLACK CHROMATE  
"K" STYLE: STAINLESS STEEL,  
300 SERIES, WITH PASSIVATION

REVISION HISTORY		
REVISION	DATE	COMMENT

1/4-28 NF THREAD

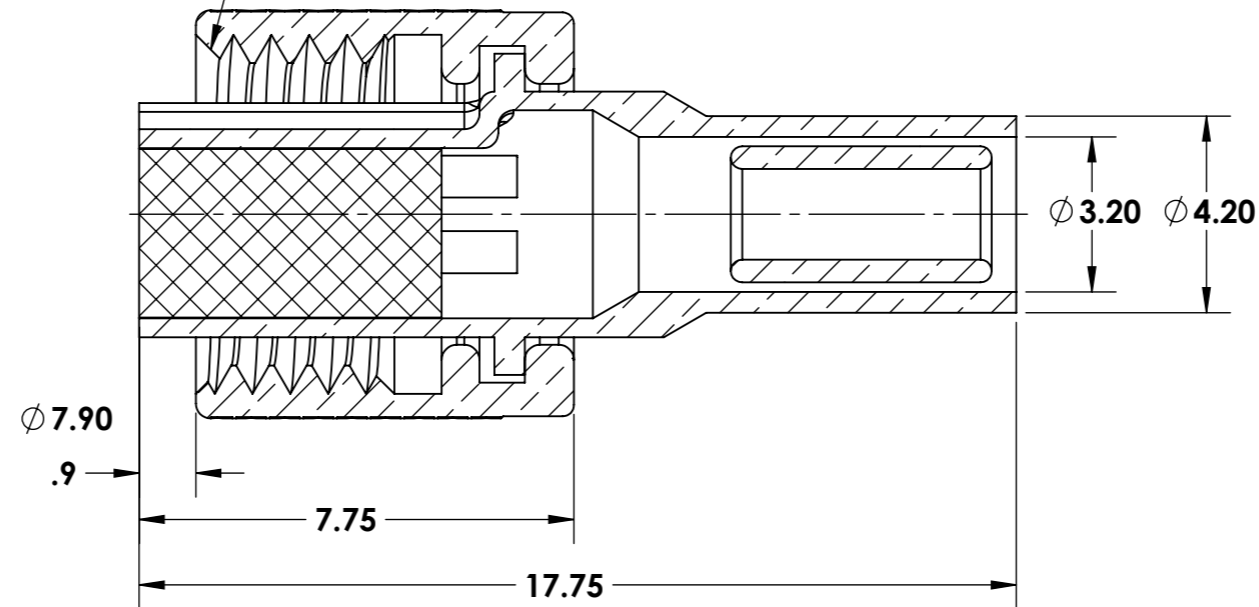

Layout

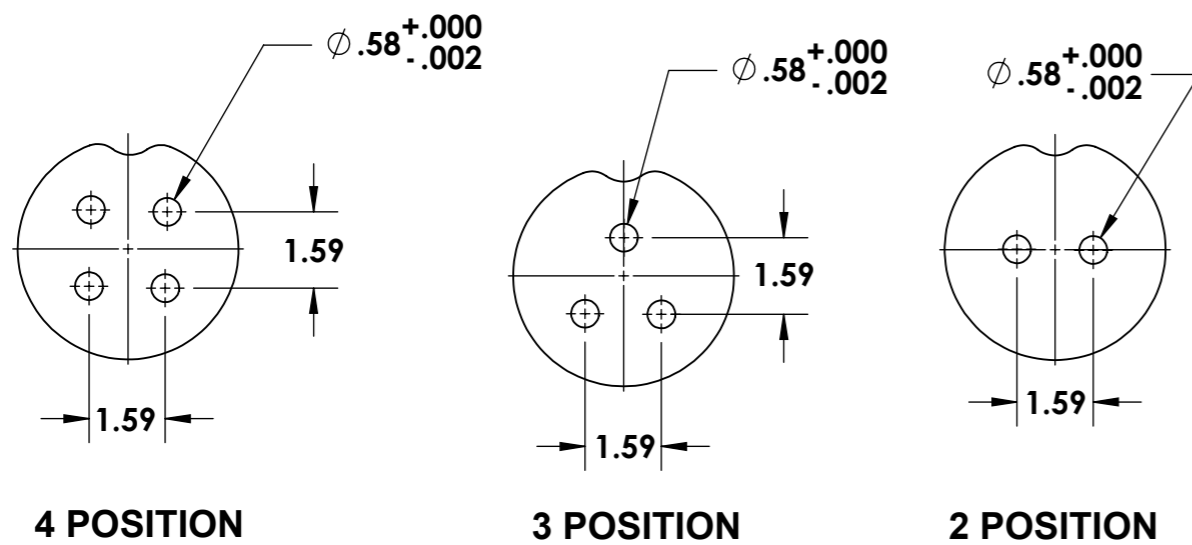

UNLESS OTHERWISE NOTED:  
DIMENSIONS ARE IN MILLIMETERS  
DO NOT SCALE THIS DRAWING

.X DECIMALS ARE ±0.5  
.XX DECIMALS ARE ±0.25  
.XXX DECIMALS ARE ±0.13

ANGLES ARE ±0.5°

DRAWING	SC	MILSPECWEST- MICRO PRODUCTS	
CHECKED	TS	DESCRIPTION: MSW PLUG	
Q.A.	KB	DWG. NO. MSW-G-B***	REVISION: 0
		SHEET 1 OF 2	

THIS DOCUMENT IS SOLE PROPERTY OF MILSPECWEST AND IS ISSUED IN STRICT CONFIDENCE THAT IT WILL NOT BE REPRODUCED IN ANY WAY OR USED TO SOLICIT BUSINESS OF A COMPETITIVE NATURE. DISTRIBUTION OF THIS DOCUMENT IS PROHIBITED UNLESS WRITTEN CONSENT IS OBTAINED FROM MILSPECWEST. THIS DOCUMENT IS SUITABLE FOR ENGINEERING EVALUATION AND MAY BE USED IN TECHNICAL SPECIFICATIONS.

**NOTES:**

- 1. MATERIALS: "G" STYLE
  - 1.1 SHELL, FERRULE  
BRASS PER QQ-B-626  
FINISH: GOLD, OVER  
ELECTROLESS NICKEL  
PER MIL-G-45204, TYP 2, CLASS 1
  - 1.2 INSERT  
PEEK, GLASS FILLED PER  
MIL-P-46183
  - 1.3 CONTACTS  
COPPER ALLOY  
FINISH: GOLD PER MIL-G-45204
  - 1.4 GASKETS  
SILICONE RUBBER PER AMS 3304
  - 1.5 ALTERNATE SHELL MATERIALS  
AND FINISHES:  
"M" STYLE: BRASS, WITH  
ELECTROLESS NICKEL FINISH  
PER AMS-C-26074, CLASS 4, GRADE B  
"A" STYLE: BRASS, WITH GOLD PLATE,  
BLACK CHROMATE  
"K" STYLE: STAINLESS STEEL,  
300 SERIES, WITH PASSIVATION

**PART NUMBER BREAKDOWN**

**MSW - G - B - 04 S**

**P = PIN**  
**S = SOCKET**

**NUMBER OF CONTACTS**  
02  
03  
04

**SHELL SIZE (SEE TABLE 2)**  
**BODY STYLE**  
B = PLUG  
R = IN LINE RECEPTACLE  
C = STRAIGHT PCB MOUNT  
D = FRONT PANEL JAM NUT MOUNT  
E = FRONT PANEL SOLDER MOUNT  
F = RIGHT ANGLE PCB MOUNT

**FINISH AND MATERIAL**  
G = BRASS WITH GOLD OVER ELEC NICKEL  
M = BRASS WITH ELECTROLESS NICKEL  
A = BRASS WITH BLACK ANODIZE  
K = STAINLESS STEEL WITH PASSIVATION

**BASIC PART NUMBER**

THIS DOCUMENT IS SOLE PROPERTY OF MILSPECWEST AND IS ISSUED IN STRICT CONFIDENCE THAT IT WILL NOT BE REPRODUCED IN ANY WAY OR USED TO SOLICIT BUSINESS OF A COMPETITIVE NATURE. DISTRIBUTION OF THIS DOCUMENT IS PROHIBITED UNLESS WRITTEN CONSENT IS OBTAINED FROM MILSPECWEST. THIS DOCUMENT IS SUITABLE FOR ENGINEERING EVALUATION AND MAY BE USED IN TECHNICAL SPECIFICATIONS.

**REVISION HISTORY**

REVISION	DATE	COMMENT
0	02/17/2017	

**SPECIFICATIONS:**

**ELECTRICAL:**

ELECTRICAL RESISTANCE: 10,000 M OHMS PER MIL-C-22557  
 RATED WORKING VOLTAGE: 400V @ SEA LEVEL  
 DIELECTRIC WITHSTANDING: 1,000 V @ SEA LEVEL PER MIL-C-22557  
 CONTACT VOLTAGE DROP: 4 mV @ 1 AMP PER MIL-C-22557  
 CONTACT RESISTANCE: 4 MOHM @ 1 AMP PER MIL-C-22557  
 CONTACT CURRENT RATING: 3 AMP

**ENVIRONMENTAL:**

VIBRATION: MIL STD 202A METHOD 204 TEST COND B (15G's)  
NO DISCONTINUITY IN EXCESS OF 1 MICROSECOND  
 SHOCK: MIL STD 202 METHOD 202, 300 G's NO EVIDENCE OF DAMAGE  
 TEMPERATURE CYCLING: MIL STD 202 METHOD 102, CONDITION C  
 CORROSION (SALT SPRAY): MIL STD 202 METHOD 10, COND B 5% SALT SOLUTION  
 MOISTURE RESISTANCE: MIL STD 202C METHOD 106B, OMITTING STEO 7B  
AND HIGH HUMIDITY TESTS

**MECHANICAL:**

CONTACTS: CONTACTS ARE CONTRAINED IN BOTH DIRECTIONS  
 ENGAGING FORCE: 0.8N PER CONTACT  
 COUPLING RETENTION TORQUE: 60 Nmm  
 CONTACT DURABILITY: 5000 CYCLES WITHH CONTACT RESISTANCE  
WITHIN MIN MIL-C-22557  
 CABLE RETENTION: SEPARATION FORCE EQUAL TO BREAKING STRENGTH  
OF SHIELD OF THE CABLE PER MIL-C-22557

UNLESS OTHERWISE NOTED:  
DIMENSIONS ARE IN MILLIMETERS  
DO NOT SCALE THIS DRAWING

.X DECIMALS ARE ±0.5  
.XX DECIMALS ARE ±0.25  
.XXX DECIMALS ARE ±0.13

ANGLES ARE ±0.5°

DRAWING	SC	<b>MILSPECWEST - MICRO PRODUCTS</b>	
		<b>CAGE CODE: 3HD49</b>	
CHECKED	TS	DESCRIPTION: <b>MICRO PLUG</b>	
Q.A.	KB	DWG. NO. <b>MSW*-B-***</b>	REVISION: 0
			SHEET 2 OF 2