

dsPIC Ready2™

Manual

All Mikroelektronika's development systems feature a large number of peripheral modules expanding microcontroller's range of application and making the process of program testing easier. In addition to these modules, it is also possible to use numerous additional modules linked to the development system through the I/O port connectors. Some of these additional modules can operate as stand-alone devices without being connected to the microcontroller.

Additional board

 **MikroElektronika**

SOFTWARE AND HARDWARE SOLUTIONS FOR EMBEDDED WORLD ...making it simple

dsPIC Ready2

The dsPIC Ready2 additional board is used to experiment with dsPIC® microcontrollers in DIP40 package.

Key features:

- Data transfer via USB-UART communication;
- Programming via the external programmer;
- Pads;
- 8 to 16V AC/DC power supply voltage;

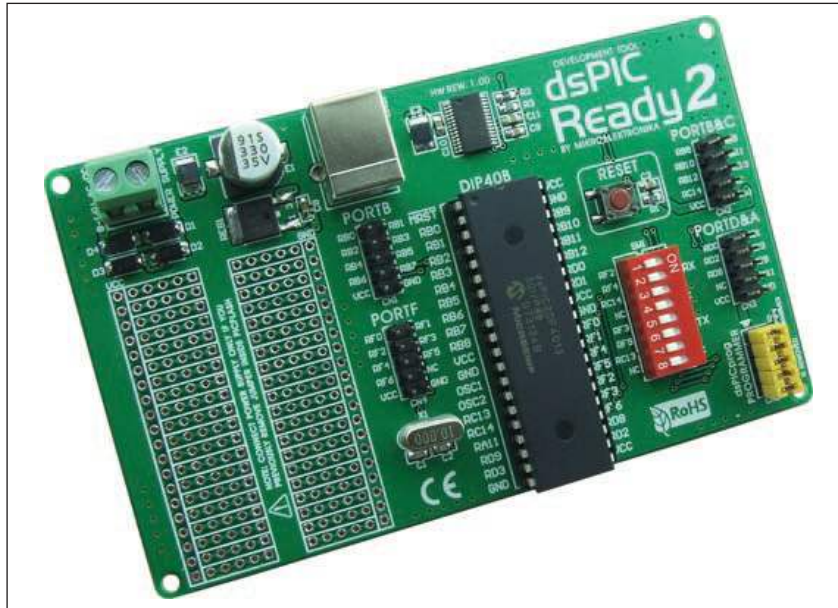

Figure 1: dsPIC Ready2 additional board

How to connect the board?

The dsPIC Ready2 board features four 2x5 connectors (CN1 - CN4) that enable connection between the pins of the microcontroller plugged into the appropriate socket on the board and external devices. A 2x5 connector CN6 is used to connect the **dsPICFlash** programmer to the microcontroller pins used for programming. A USB connector CN51 enables connection between the additional board and a PC via the UART module. In order to enable USB-UART communication, it is necessary to place the appropriate switch on the DIP switch SW1 to the ON position. By doing this, the RX and TX pins of the USB-UART module are connected to the appropriate pins of the microcontroller. The additional board is powered with a voltage in a range between 8 and 16V AC/DC via the CN8 connector.

How to use the board?

In order to use the dsPIC Ready2 additional board, it is first necessary to place a microcontroller in DIP40 package into the appropriate socket supplied on the board. The microcontroller is programmed with the dsPICFlash programmer that is plugged via its IDC10 connector into a 2x5 connector CN6 supplied on the board. In order to reset the microcontroller, just press the RESET button. When the programming process is finished, it is necessary to place jumpers over the 2x5 connector CN6, Figure 1.



Figure 2: Programming the on-board microcontroller

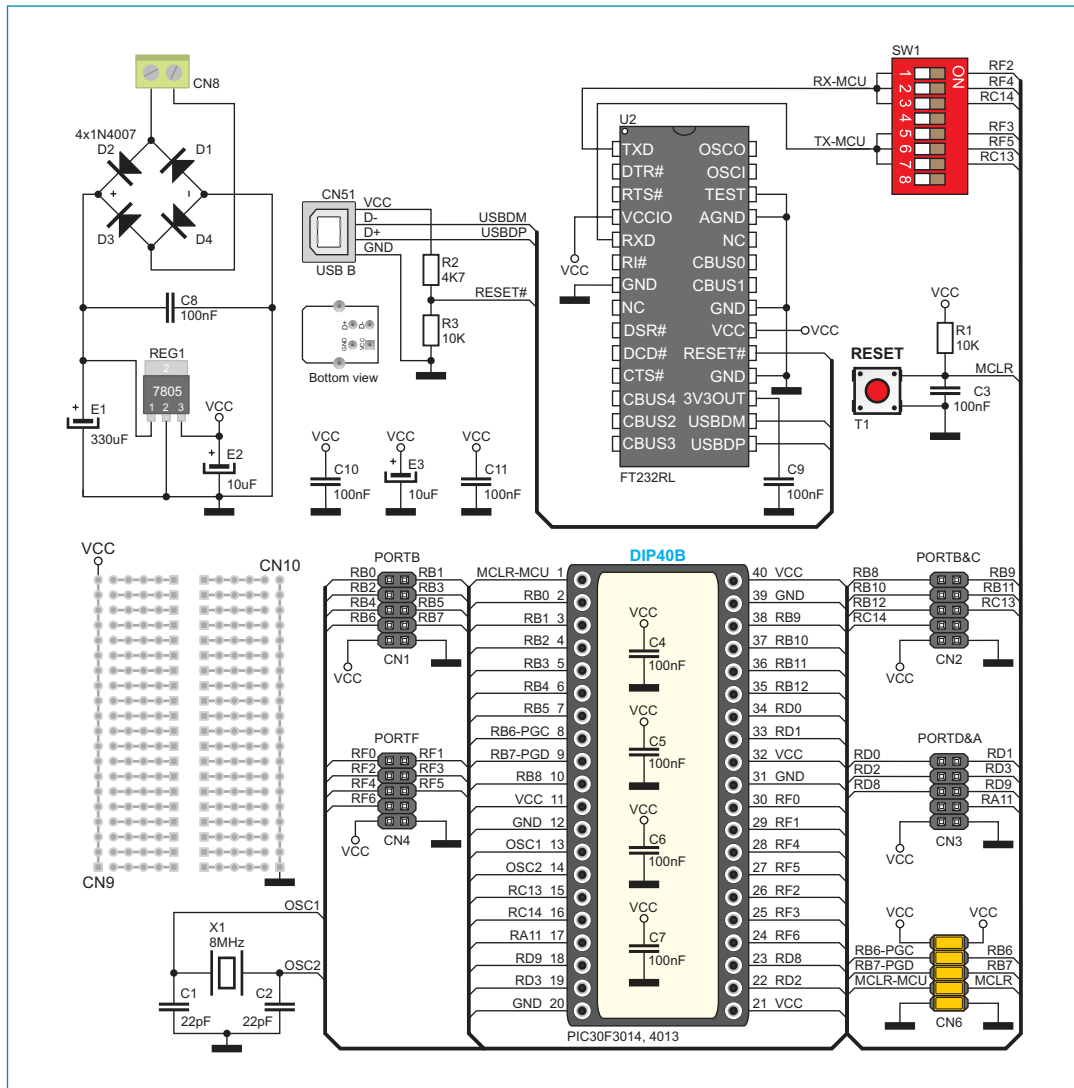

Figure 3: The dsPIC Ready2 board connection schematic

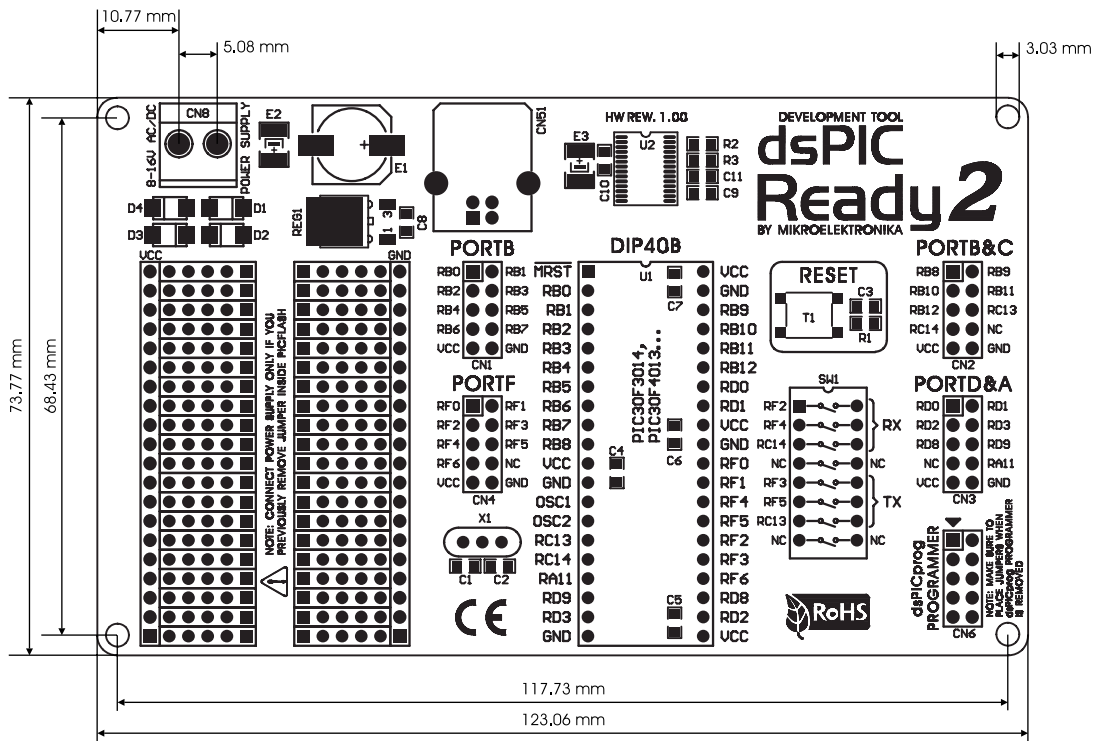

Figure 4: Dimensions of the dsPIC Ready2 additional board



MikroElektronika
SOFTWARE AND HARDWARE SOLUTIONS FOR EMBEDDED WORLD ...making it simple

If you want to learn more about our products, please visit our website at www.mikroe.com

If you are experiencing some problems with any of our products or just need additional information, please place your ticket at www.mikroe.com/en/support

If you have any questions, comments or business proposals, do not hesitate to contact us at office@mikroe.com