



MU-Series



## MU-35

**Miniature DC Volt Meter  
3 1/2 Digit 0.315" LED  
in a 1/32 DIN Case**



**A Multi-range, Easily-scaled, DC Volts Measuring, AC/DC Powered LED Meter.**

### General Features

The MU-35 is a miniature, streamlined DC voltage measuring meter. The meter has three built-in header selectable ranges of 2V, 20V and 200V. It is specifically designed to be easily user-scaled and calibrated to almost any conceivable engineering unit, such as temperature, pressure, viscosity or flow rates, etc., without requiring component changes.

On site scaling and recalibration is facilitated by multi-turn potentiometer that provide continuous adjustment within each of three header-programmable full scale ranges for span and zero offset. Display Hold and Display Test functions are also provided. The standard meters have a high efficiency red LED display. Green displays may also be specified. (See ordering information for available choices).

The MU-35 interconnects by means of a push-on screw terminal that is provided with the meter. A high quality, internally isolated, wide range, switching supply is built into every MU-35 meter. This allows the meter to operate from a wide range of AC or DC voltages. (See specifications.) The isolation ensures that ground loop currents do not affect the meter stability.

### Typical Application Connections

**DC Volts Single-ended** measurement with a Resolution of 100 milliVolt.

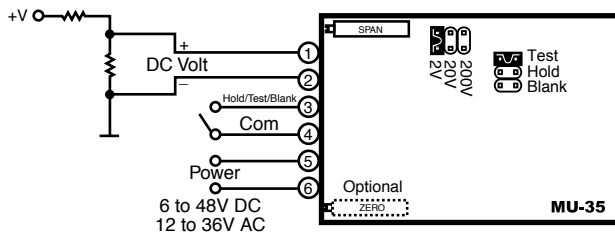

**DC Volts Differential** measurement with a Resolution of 100 milliVolt.

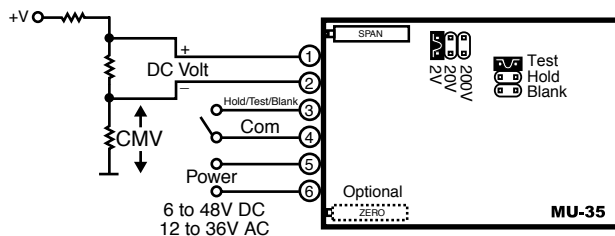

Max CMV (common mode voltage) is 50V.\*

\*Because CMV is common with meter ground, higher CMV inputs to a max of 1KV, require mechanical isolation of all contactable meter parts.

### Compatibility

The MU-Series have a matching DIN case style that is complementary to the Lynx, Leopard and Tiger family of meters. MU-Meters are the OEM's choice for economical switchboard and process indication. For economy, each model is dedicated to a specific application and designed for quick and easy installation.



### Specifications

- Input Configuration:** ..... Single-ended with optional provision to offset the zero of the reading being displayed
- Input Impedance:** ..... 1M minimum
- Full Scale Ranges:** ..... Three built-in header selectable ranges of  $\pm 2V$  DC,  $\pm 20V$  DC and  $\pm 200V$  DC full scale
- A/D Converter:** ..... 12 Bit Dual Slope
- Accuracy:** .....  $\pm (0.05\%$  of reading + 2 digits)
- Temperature Coefficient:** ..... 100ppm/ $^{\circ}C$  (Typical)
- Warm up Time:** ..... One minute to specified accuracy
- Conversion Rate:** ..... 3 readings per second
- Display:** ..... 0.315" High Efficiency Red LED, optional Green LED, optional non-functional, right hand side dummy zero available
- Decimal Selection:** ..... User programmable to 4 positions
- Over-range Indication:** ..... If input exceeds full scale on any range being used, most significant "1" digit & polarity symbol is displayed all other digits blank.
- Power Supply:** ..... 6V DC to 48V DC or 12V AC to 36V AC. Approximately 1.5 watts.
- Operating Temperature:** .....  $0^{\circ}C$  to  $+50^{\circ}C$
- Storage Temperature:** .....  $-20$  to  $70^{\circ}C$
- Relative Humidity:** ..... 95% (non-condensing)
- Case Dimensions:** ..... 1/32 DIN (Bezel 48Wx24Hmm) Depth behind bezel (3.19") 81mm Plus (0.38") 9.5mm for connector
- Weight:** ..... 312 gms (11oz)  
397 gms (14 oz) when packed

## MU-Series, the OEMs choice for DC voltage measuring

MU-35 . . . . .3.5 digit,  $Is_{2/20/200}$  VDC, 5-36VDC/12-24VAC Pwr

MU-35CL . . .3.5 digit, Iso., 4-20mA input, 5-36VDC/12-24VAC Pwr

## Functional Diagram

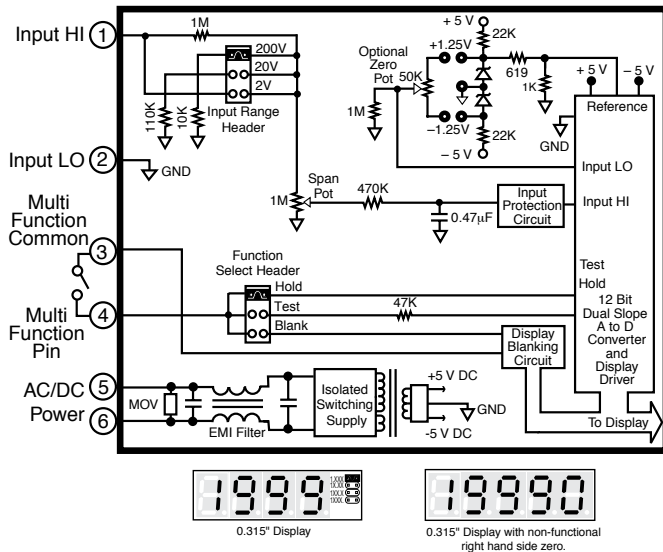

## Component Layout

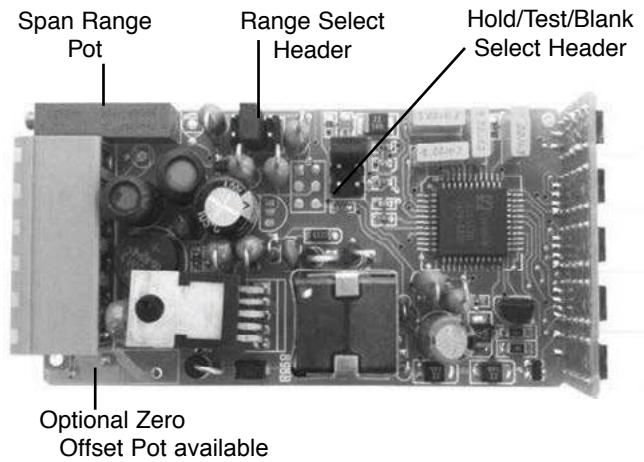

## Signal Conditioning Components

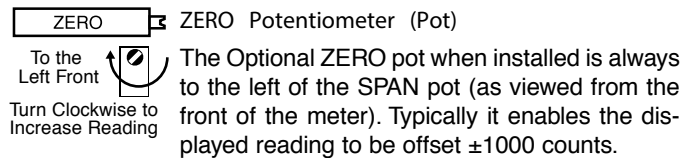
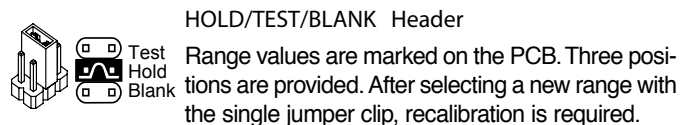
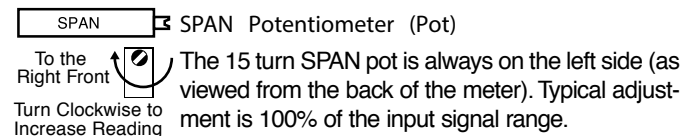
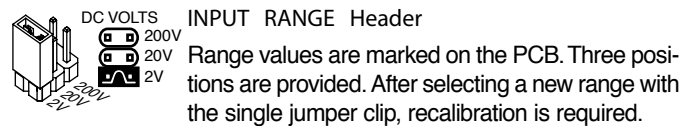

## Calibration Procedure

1. Select the required full scale voltage range, by repositioning the jumper clip on the range select header. Ranges of 2V, 20V and 200V full scale may be selected.
2. Apply an input of 0 volts. If the Zero Offset Pot is installed, adjust the pot until the meter reads 000. If no Zero Offset Pot is installed, the meter will auto-zero.
3. Apply an input equal to 95% of the full scale voltage.
4. Adjust the Span Pot until the meter displays the required reading.
5. The MU-35 is now calibrated and ready for use. (Whenever a new range is selected, re-calibration is required to meet the specified accuracy.)

## Connector Pinouts

The MU-35 interconnects by means of screw terminals. The screw terminal connector is provided with the meter.

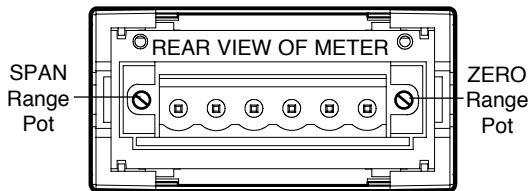

**Pin 1 - Signal Input High:** Signal input high for the meter. Full scale ranges of 2V, 20V or 200V can be selected on the Range Select Header.

**Pin 2 - Signal Input Low:** Signal input low for the meter. Full scale ranges of 2V, 20V or 200V can be selected on the Range Select Header.

**Pin 3 - Hold/Test/Blank:** Depending on the position of the internal jumper clip, connecting Pin 3 to Pin 4 will activate one of three special functions. If display hold is selected, the meter display will be latched. A/D conversions will continue but the display will not be updated until Pin 3 is disconnected from Pin 4.

TEST  
 HOLD  
 BLANK

If Display Test is selected -1888 will be displayed to check for defective segments. Until Pin 3 is disconnected from Pin 4.

TEST  
 HOLD  
 BLANK

If Display Blank is selected the display can be blanked to conserve power. A/D conversions will continue, so that the display will show the true value of the input immediately when Pin 3 is disconnected from Pin 4.

**Pin 4 - Hold/Test/Blank/Common:** Connect this pin to Pin 3 to activate Hold, Test or Blank as explained above.

**Pin 5 & 6 - Power Input 1:** The MU-35 operates from any voltage from 6V DC to 48V DC or 12V AC to 36V AC. The power input is not polarity sensitive. The MU-35 consumes about 1.5 Watts of power.

## Decimal Point Selection

### For Standar Display

Decimal point position is selected on the Decimal Point Select Header on the Display Board.

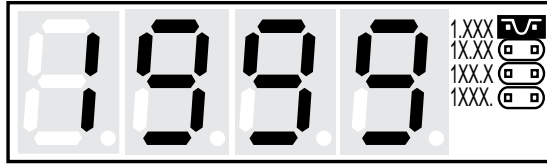

## Removing Meter From Case

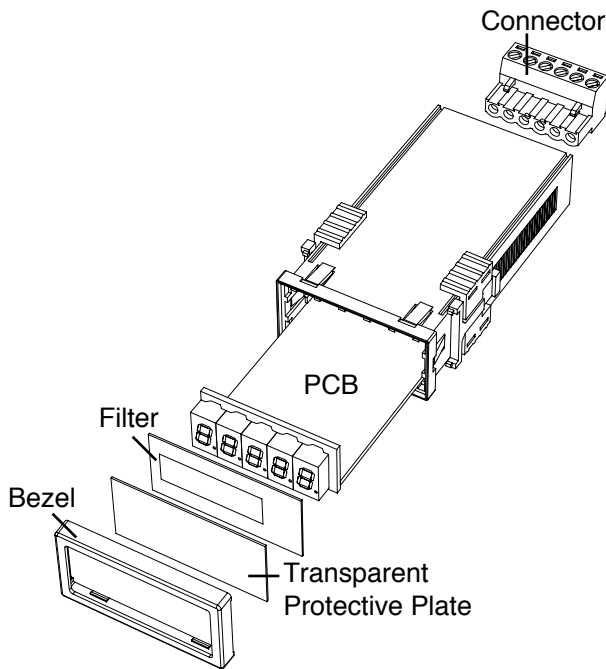

Due to the small size and the wide range power supply of the MU-35, it can fit into a variety of applications such as automotive, marine, utility, process industry, mosaic panels, clean room and in portable instrumentation.

## Connector

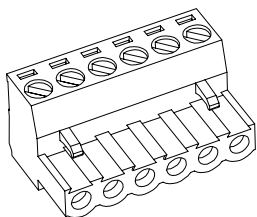

Input Power  
Screw Terminal Plug

Part Numbers:  
93-PLUG6P-ST.....6 pins

## Front Bezel Descriptors

C	⊗	kV	kVAR	m <sup>3</sup> /hr	Hz	M
V	mV	min	PF	°F	°C	CosØ
DC	x10kN	μA	PSIG	mS	kg/cm <sup>2</sup>	psi
kW	W	kWH	pH	%	K	kPa
A	mbar	mA	MW	kA	RPS	MWH
mWs	μm	kW/s	l	l/sec	ml	cm
ORP	mm/s	1/min	mm	kg/sec	lbs	kg/hr
FT	bars	min <sup>-1</sup>	m/min	Mvars	μV	dB

To customize the front bezel, each DU-meter is supplied with a white printed clear adhesive label containing various popular descriptors. Choose the descriptors desired, peel off the adhesive backing and align the descriptors in the center right of the faceplate.

## Custom Face Plates



### Texmate Produces Thousands of Custom OEM Face Plates

Have Texmate Design and Build a Custom Face Plate to Suit your Next project!

- Custom face plates have a non-recurring artwork charge. A serial number is then assigned to each artwork, to facilitate reordering.
- Small Run or One-Off custom face plates incur an installation charge, and are generally printed on a special plastic film, which is then laminated to custom faceplate blanks as required.
- Large Run (250 pieces min): custom face plates are production silk screened, issued a part number, and held in stock for free installation as required by customer orders.
- OEMs may also order Custom Meter Labels, Box Labels Custom Data Sheets and Instruction Manuals.

## Clear Lockable Water-proof Cover

The clear lockable cover is designed to be dust and water proof to NEMA-4X, IP65 standards. The assembly consists of a base and cover with a cam hinge and key-lock fastening mechanism. An O-ring, or neoprene gasket forms a seal between the base and the panel. The cam hinge prevents the cover from closing when opened until pushed closed. The cover has a tapered recess that, when closed, forms a seal with a tapered spigot on the base. A key-lock employs a cam locking device to force the spigot into the recess, ensuring seal integrity. A safety catch keeps the cover closed even when the key is removed, and the keyhole can be used to attach a safety seal clip, preventing unauthorized opening.

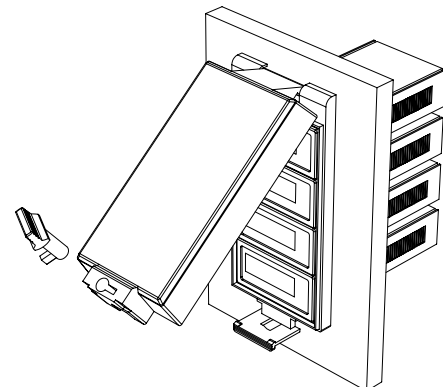

# MU Case Dimensions and Panel Cutouts

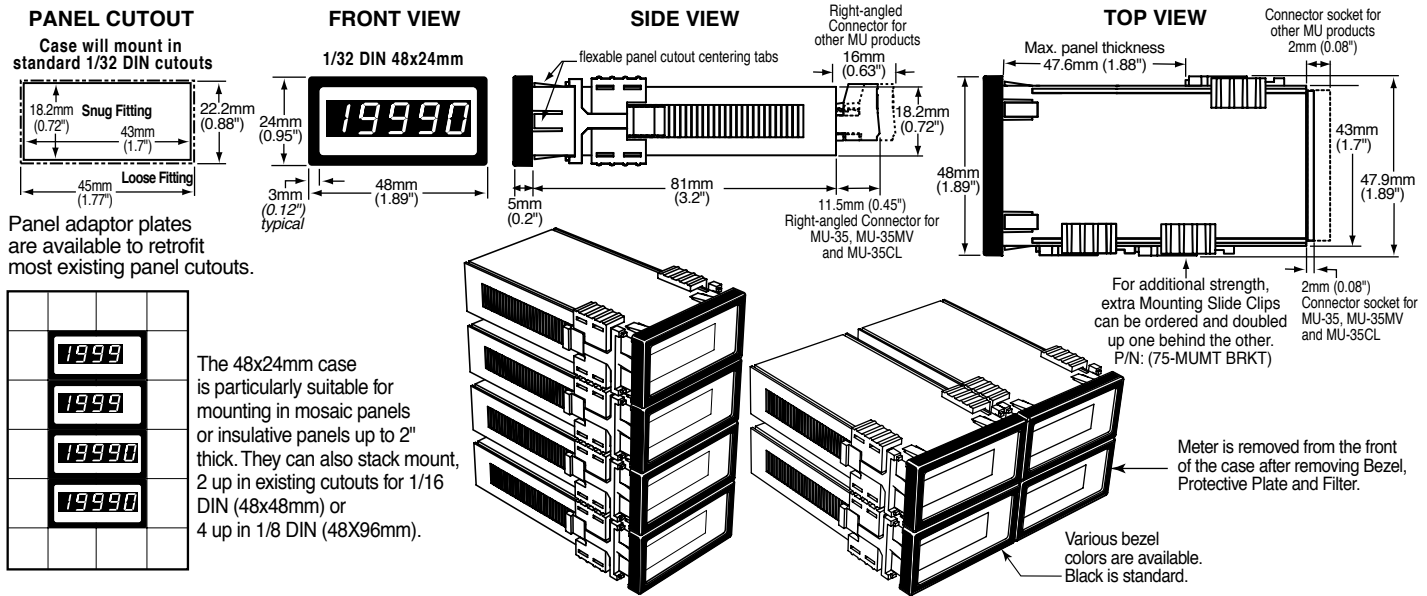

## Ordering Information

### Standard Options for this Model Number

Part Number	Description	List
<b>► BASIC MODEL NUMBER</b> Includes plug in type screw terminals, standard display and standard power supply unless optional versions are ordered.		
MU-35 .....	3.5 digit, Iso., 2/20/200 VDC, 5-36VDC/12-24VAC Pwr	
<b>► DISPLAY</b>		
<b>STANDARD... Red LED, 0.3 inch high</b>		
MU-GREEN.....	Green LED	
MU-RED4.5 .....	Dummy Zero Display Option w/ RED Display	
MU-GREEN4.5 ...	Dummy Zero Display Option w/ Green Display	

### Special Options and Accessories

Part Number	Description
<b>► SPECIAL OPTIONS (Specify Inputs &amp; Req. Reading)</b>	
HD-CHANGE ..	Range change from the standard input as shown in BOLD Type.
V0-50K .....	Zero offset potentiometer 50k
CB-FS35 .....	Non-Std Range and Scale Changes
<b>► ACCESSORIES</b>	
MU-CASE48X24 ..	48x24mm Complete Case with Bezel .
75-MUBEZEL .....	Black Bezel for 48x24mm Case
75-MUMTBRKT ..	Mounting Slide Clips, extra set (48x24mm case size) .

### WARRANTY

Texmate warrants that its products are free from defects in material and workmanship under normal use and service for a period of one year from date of shipment. Texmate's obligations under this warranty are limited to replacement or repair, at its option, at its factory, of any of the products which shall, within the applicable period after shipment, be returned to Texmate's facility, transportation charges pre-paid, and which are, after examination, disclosed to the satisfaction of Texmate to be thus defective. The warranty shall not apply to any equipment which shall have been repaired or altered, except by Texmate, or which shall have been subjected to misuse, negligence, or accident. In no case shall Texmate's liability exceed the original purchase price. The aforementioned provisions do not extend the original warranty period of any product which has been either repaired or replaced by Texmate.

### USER'S RESPONSIBILITY

We are pleased to offer suggestions on the use of our various products either by way of printed matter or through direct contact with our sales/application engineering staff. However, since we have no control over the use of our products once they are shipped, NO WARRANTY WHETHER OF MERCHANTABILITY, FITNESS FOR PURPOSE, OR OTHERWISE is made beyond the repair, replacement, or refund of purchase price at the sole discretion of Texmate. Users shall determine the suitability of the product for the intended application before using, and the users assume all risk and liability whatsoever in connection therewith, regardless of any of our suggestions or statements as to application or construction. In no event shall Texmate's liability, in law or otherwise, be in excess of the purchase price of the product.

Texmate cannot assume responsibility for any circuitry described. No circuit patent or software licenses are implied. Texmate reserves the right to change circuitry, operating software, specifications, and prices without notice at any time.



450 State Place • Escondido, CA 92029  
Tel: 1-760-598-9899 • USA 1-800-839-6283 • That's 1-800-TEXMATE  
Fax: 1-760-598-9828 • Email: orders@texmate.com • Web: www.texmate.com

For product details visit [www.texmate.com](http://www.texmate.com)  
Local Distributor Address