

Features

- High accurate: $\pm 1.5\%$ (25°C)
- Operating voltage range: 1.0V ~ 5.5V
- Operating temperature range: -40°C to + 85°C
- Detect voltage temperature characteristics: $\pm 2.5\%$
× TYP
- Output configuration: Bi-dir
- Reset timeout period: typical 200ms

Description

The PT7M1233/1233A series are designed to monitor power supplies in μP and digital systems. They provide excellent circuit reliability and low cost by eliminating external components and adjustments.

The devices perform a single function: assert a reset signal whenever the V_{CC} supply voltage falls below a preset threshold. Reset remains asserted 200ms after V_{CC} has risen above the reset threshold.

PT7M1233/1233A are bidirectional output, allowing it to monitor a pushbutton on the reset output.

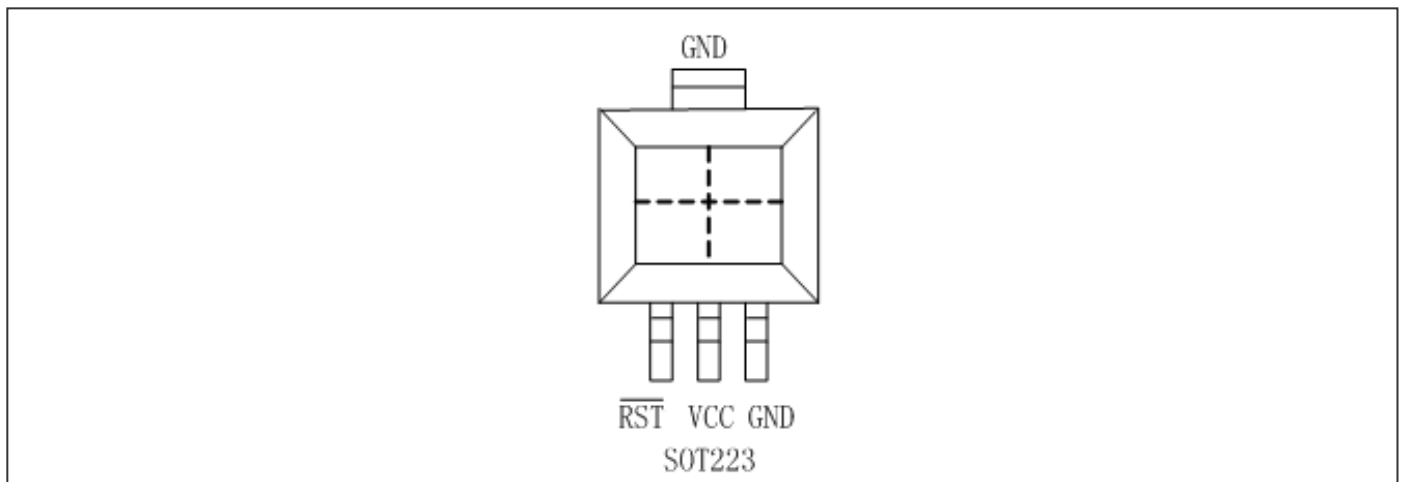
Pin Configuration

Pin Description

Name	Type	Description
$\overline{\text{RST}}$	I/O	Reset Output and Pushbutton Input: $\overline{\text{RST}}$ is asserted when V_{CC} drops below voltage threshold V_{TH} . Active low. When other devices pull $\overline{\text{RST}}$ low, the reset condition occurs and will remain a reset timeout period at least 200ms.
GND	P	Ground
VCC	P	Supply Voltage.

Maximum Ratings

Storage Temperature	-65°C to +150°C
Ambient Temperature with Power Applied	-40°C to +85°C
Supply Voltage to Ground Potential (V _{CC} to GND)	-0.3V to +7.0V
DC Input Voltage (All inputs except V _{CC} and GND).....	-0.3V to V _{CC} +0.3V
DC Output Current (All outputs)	30mA
Power Dissipation	320mW (Depend on package)

Note:

Stresses greater than those listed under MAXIMUM RATINGS may cause permanent damage to the device. This is a stress rating only and functional operation of the device at these or any other conditions above those indicated in the operational sections of this specification is not implied. Exposure to absolute maximum rating conditions for extended periods may affect reliability.

DC Electrical Characteristics

(T_A = -40~85°C, unless otherwise noted. Typical values are at T_A = +25°C)

Description		Sym.	Test Conditions	Min	Typ	Max	Unit
Supply Voltage		V _{CC}		1.0	-	5.5	V
Supply Current		I _{CC}	V _{CC} = 5.5V. No load.	-	-	12	μA
			V _{CC} = 3.6V. No load.	-	-	10	μA
Voltage Threshold		V _{TH-}	+25°C	(V _{TH-}) ×0.985	V _{TH-}	(V _{TH-}) ×1.015	V
			-40°C~85°C	(V _{TH-}) ×0.975	V _{TH-}	(V _{TH-}) ×1.025	V
Voltage Threshold (PT7M1233A-10)		V _{TH-}	+25°C	(V _{TH-}) ×0.985	2.88	(V _{TH-}) ×1.015	V
			-40°C~85°C	(V _{TH-}) ×0.975	2.88	(V _{TH-}) ×1.025	V
Voltage Threshold (PT7M1233A-15)		V _{TH-}	+25°C	(V _{TH-}) ×0.985	2.72	(V _{TH-}) ×1.015	V
			-40°C~85°C	(V _{TH-}) ×0.975	2.72	(V _{TH-}) ×1.025	V
Hysteresis		V _{HYS}	V _{TH+} - V _{TH-} *	-	50	-	mV
Output Driving	Output low	V _{OL}	I _{OH} = 8mA, V _{CC} = 5V	-	-	0.4	V
			I _{OH} = 4mA, V _{CC} = 3V	-	-	0.3	
			I _{OH} = -50μA, V _{CC} = 1V	-	-	0.09	

Note: V_{TH-} is voltage threshold when V_{CC} falls from high to low. V_{TH+} is voltage threshold when V_{CC} rises from low to high.

AC Electrical Characteristics

Timing diagram

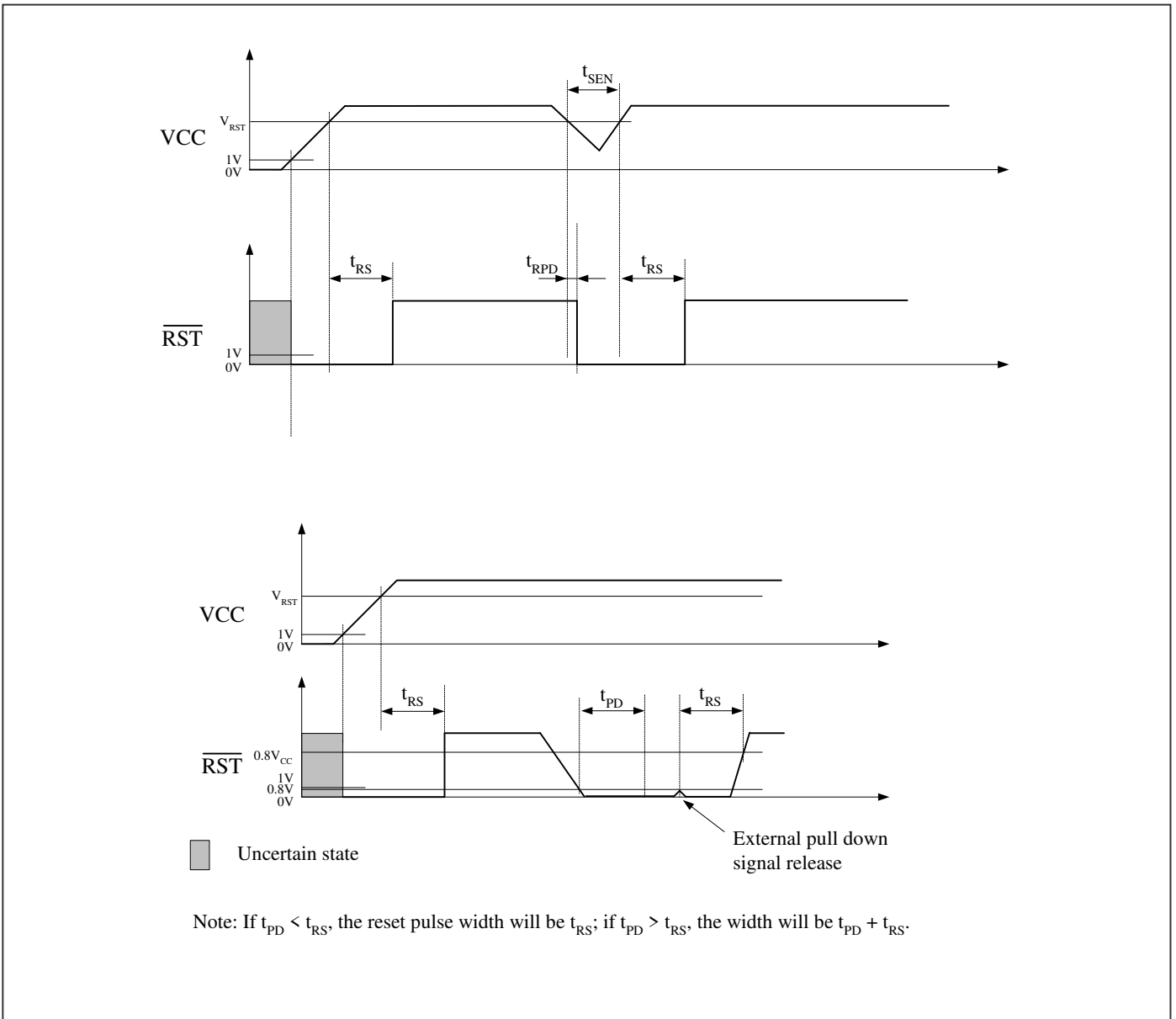

($V_{CC} = 1.0V$ to $5.5V$, $T_A = -40 \sim 85^\circ C$, unless otherwise noted. Typical values are at $T_A = +25^\circ C$)

Sym.	Description	Test Conditions	Min	Typ	Max	Unit
t_{RS}	Reset Timeout Period	-	140	200	280	ms
t_{RPD}	Delay	-	-	17	-	μs
t_{SEN}	Sensitivity	-	20	-	-	μs
t_{PD}	External Pull Down Signal Pulse	\overline{RST} pin	1	-	-	μs
	Pushbutton Debounce	\overline{RST} pin	140	200	280	ms
	Pushbutton Detect*	\overline{RST} pin	0.8	1.5	2.0	V

*Note: \overline{RST} will be asserted when it is pull down to the typical value or less.

Block Diagram

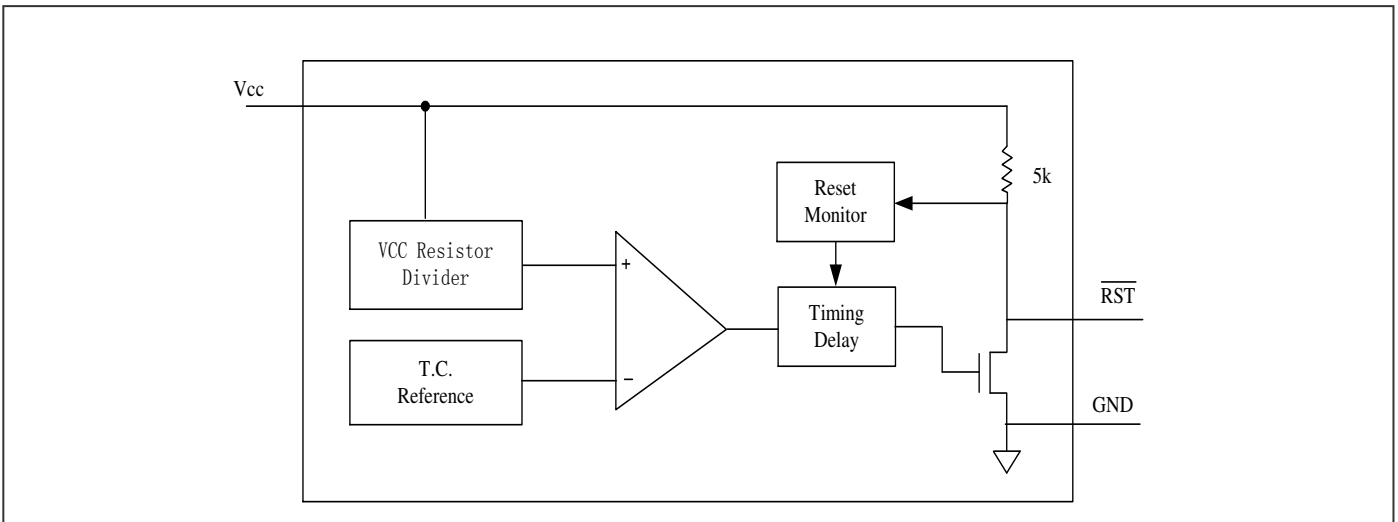

Function Description

Power Monitor

A microprocessor's (μP 's) reset input starts the μP in a known state. Whenever the μP is in an unknown state, it should be held in reset. The supervisory circuits assert reset during power-up and prevent code execution errors during power-down or brownout conditions.

On power-up, once V_{cc} reaches about 1.0V, $\overline{\text{RST}}$ is a guaranteed logic low of 0.4V or less. As V_{cc} rises, $\overline{\text{RST}}$ stays low. When V_{cc} rises above the reset threshold V_{RST} , an internal timer releases $\overline{\text{RST}}$ after about 200ms. $\overline{\text{RST}}$ asserts whenever V_{cc} drops below the reset threshold, i.e. brownout condition. If brownout occurs in the middle of a previously initiated reset pulse, the pulse continues for at least another 200ms. On power-down, once V_{cc} falls below the reset threshold, $\overline{\text{RST}}$ stays low and is guaranteed to be 0.4V or less until V_{cc} drops below 1V.

Reset Output: Bi-direction

PT7M1233

The devices provide $\overline{\text{RST}}$ output pin for a pushbutton switch. When the devices are not in a reset cycle, it continuously monitors the $\overline{\text{RST}}$ signal for a low going edge. If an edge is detected, the devices will debounce the switch by pulling the $\overline{\text{RST}}$ line low. After the internal timer has expired, the devices will continue to monitor the $\overline{\text{RST}}$ line. If the line is still low, they will continue to monitor the line looking for a rising edge. Upon detecting a release, they will force the $\overline{\text{RST}}$ line low and hold it low for 200ms.

PT7M1233A

When an out-of-tolerance condition is detected, an internal power fail signal is generated which forces reset to the active state. When V_{cc} returns to an in-tolerance condition, the reset signal is kept in the active state for approximately 200ms to allow the power supply and processor to stabilize. The second function of the PT7M1233A is pushbutton reset control. The PT7M1233A debounces a pushbutton closure and will generate a 200ms reset pulse upon release.

Application Information

Typical Operation Circuit

PT7M1233 Application Example

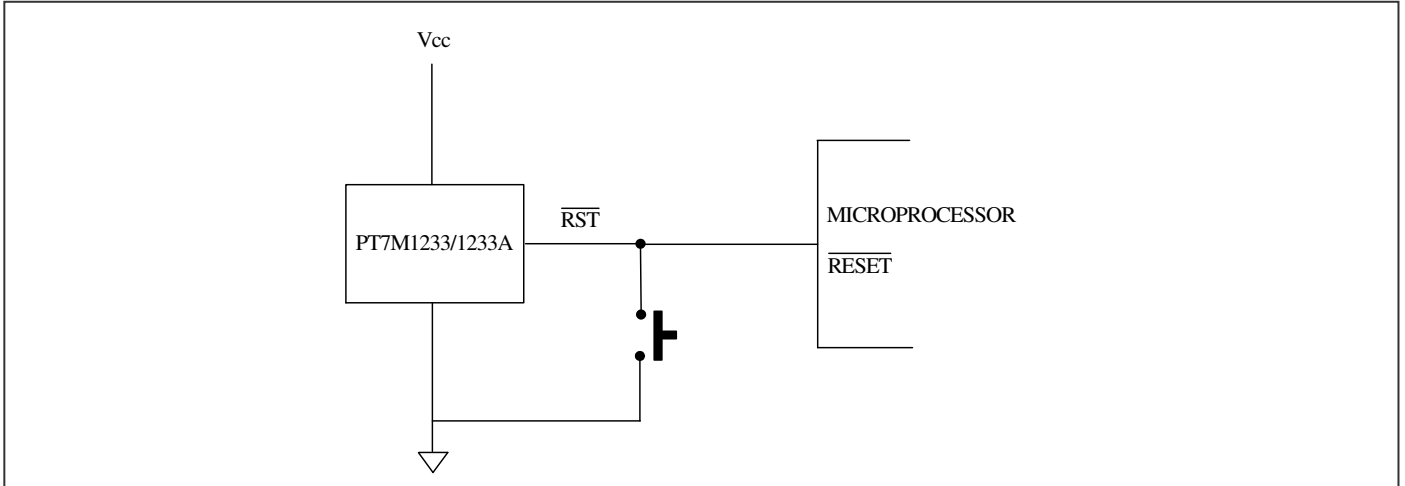

Mechanical Information

TC (SOT223-3)

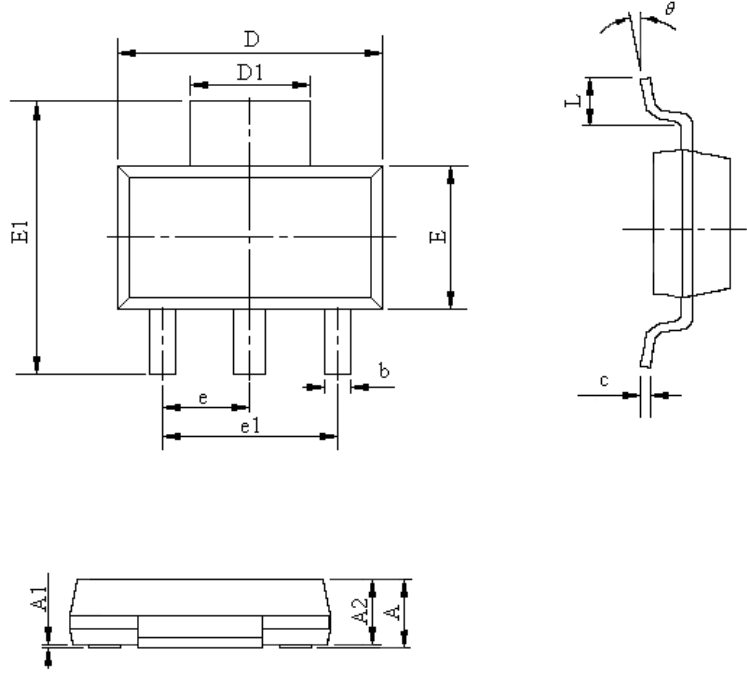
	DOCUMENT CONTROL NO. PD-0022																																													
	REVISION: B DATE: 5/16/2011																																													
<table border="1" style="width: 100%; border-collapse: collapse;"> <thead> <tr> <th colspan="3">PKG. DIMENSIONS(MM)</th> </tr> <tr> <th>SYMBOL</th> <th>MIN</th> <th>MAX</th> </tr> </thead> <tbody> <tr> <td>A</td> <td>1.52</td> <td>1.8</td> </tr> <tr> <td>A1</td> <td>0</td> <td>0.1</td> </tr> <tr> <td>A2</td> <td>1.5</td> <td>1.7</td> </tr> <tr> <td>b</td> <td>0.66</td> <td>0.82</td> </tr> <tr> <td>c</td> <td>0.25</td> <td>0.35</td> </tr> <tr> <td>D</td> <td>6.2</td> <td>6.4</td> </tr> <tr> <td>D1</td> <td>2.9</td> <td>3.1</td> </tr> <tr> <td>E</td> <td>3.3</td> <td>3.7</td> </tr> <tr> <td>E1</td> <td>6.83</td> <td>7.07</td> </tr> <tr> <td>e</td> <td colspan="2" style="text-align: center;">2.30BSC</td> </tr> <tr> <td>e1</td> <td>4.5</td> <td>4.7</td> </tr> <tr> <td>L</td> <td>0.9</td> <td>1.15</td> </tr> <tr> <td>θ</td> <td>0°</td> <td>10°</td> </tr> </tbody> </table>	PKG. DIMENSIONS(MM)			SYMBOL	MIN	MAX	A	1.52	1.8	A1	0	0.1	A2	1.5	1.7	b	0.66	0.82	c	0.25	0.35	D	6.2	6.4	D1	2.9	3.1	E	3.3	3.7	E1	6.83	7.07	e	2.30BSC		e1	4.5	4.7	L	0.9	1.15	θ	0°	10°	
PKG. DIMENSIONS(MM)																																														
SYMBOL	MIN	MAX																																												
A	1.52	1.8																																												
A1	0	0.1																																												
A2	1.5	1.7																																												
b	0.66	0.82																																												
c	0.25	0.35																																												
D	6.2	6.4																																												
D1	2.9	3.1																																												
E	3.3	3.7																																												
E1	6.83	7.07																																												
e	2.30BSC																																													
e1	4.5	4.7																																												
L	0.9	1.15																																												
θ	0°	10°																																												
<p>Note: 1) Ref: JEDEC TO-261C</p>	<p>Pericom Technology (Shanghai) Co.Ltd. 3/F., 20 Building , 481 Gui Ping Road, Shanghai,200233 Tel:(86-21)6485-0576. Fax: (86-21)6485-2181</p>																																													
	DESCRIPTION: 3-Pin SOT223																																													
	PACKAGE CODE: TC3																																													

Ordering Information

Part Number	Package Code	Package
PT7M1233-15TCE	TC	Lead free and Green SOT223
PT7M1233-10TCE	TC	Lead free and Green SOT223
PT7M1233-5TCE	TC	Lead free and Green SOT223
PT7M1233A-15TCE	TC	Lead free and Green SOT223
PT7M1233A-10TCE	TC	Lead free and Green SOT223

Note:

- E = Pb-free or Pb-free and Green
- Adding X Suffix= Tape/Reel
- Contact Pericom for availability.

Function Comparison Table

Item	Part No.	Reset Output	Threshold
1	PT7M1233-15	Bi-direct, Active low	4.1V
2	PT7M1233-10	Bi-direct, Active low	4.3V
3	PT7M1233-5	Bi-direct, Active low	4.6V
4	PT7M1233A-15	Bi-direct, Active low	2.72V
5	PT7M1233A-10	Bi-direct, Active low	2.88V

Pericom Semiconductor Corporation • 1-800-435-2336 • www.pericom.com

Pericom reserves the right to make changes to its products or specifications at any time, without notice, in order to improve design or performance and to supply the best possible product. Pericom does not assume any responsibility for use of any circuitry described other than the circuitry embodied in Pericom product. The company makes no representations that circuitry described herein is free from patent infringement or other rights, of Pericom.