

## ALPHA RF Modules

### Features

- FM Transmitter & Receiver Modules
- Available as 433 or 915MHz
- Transmit Range up to 300m
- Miniature SMT Packages
- Data Rate up to 256Kbps
- Programmable Output Power
- 2.2 – 5.4Vdc Operating Voltage
- Standby Current <300nA
- Programmable Freq Deviation
- SPI Interface (for Config)
- Clock and Reset Signal for External MCU
- Wakeup Timer
- Automatic Antenna Tuning
- Differential Antenna Output
- Low Battery Detection
- EMC Compliant , FCC Compliant
- Operates from -45 to +85°C

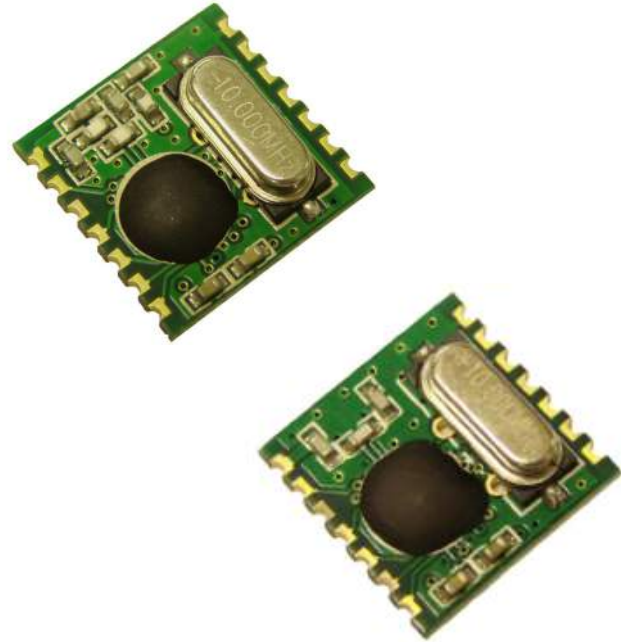

### Transmitter

- 2.2-5.4v Supply Voltage
- Programmable Output Power

### Receiver

- Standby current < 0.3uA
- Wake up timer function
- PLL Design
- Digital Signal Strength indicator
- Programmable receive bandwidth (67 to 400KHz)

### Applications

- Wireless Security Systems
- Car Alarms
- Remote Gate Controls
- Remote Sensing
- Data Capture
- Sensor Reporting

### Introduction

The Alpha Modules are extremely cost effective but high performance radio modules. Supplied in a miniature Surface mount package these modules can Transmit/Receive at upto 115Kbps at upto 300m range.

Operating at 2.2-5V, both transmitter and receiver monitor their battery voltage and can sleep with very low standby current. The modules can wake intermittently and provide direct control outputs to a microcontroller, ideally suited to battery applications. (Especially receivers!)

These Modules will suit one to one multi-node wireless links in applications including car and building security, POS and inventory tracking, remote process monitoring.

## Ordering Information

Part Number	Description
ALPHA-TX433S	FM Transmitter Module, 433MHz
ALPHA-RX433S	FM Receiver Module, 433MHz
ALPHA-TX868S	FM Transmitter Module, 868MHz
ALPHA-RX868S	FM Receiver Module, 868MHz
ALPHA-TX915S	FM Transmitter Module, 915MHz
ALPHA-RX915S	FM Receiver Module, 915MHz

## Transmitter Pin Description

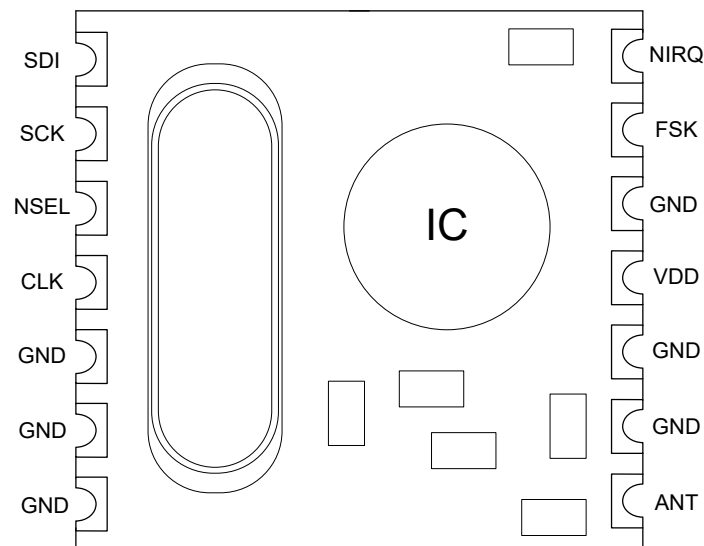

Pin	Definition	Direction	Description
1	SDI	IN	SPI Data Input
2	SCK	IN	SPI Clock Input
3	nSEL	IN	Chip select (Active Low)
4	CLK	OUT	Clock out for MCU (1-10MHz)
5,6,7	GND	-	Ground Connection
8	ANT	OUT	Antenna Connection
9,10	GND	-	Ground Connection
11	VDD	IN	Positive Power Supply
12	GND	-	Ground Connection
13	FSK	IN	FSK Data Input
14	nIRQ	OUT	Interrupt Request Out (Active Low)

## Receiver Pin Description

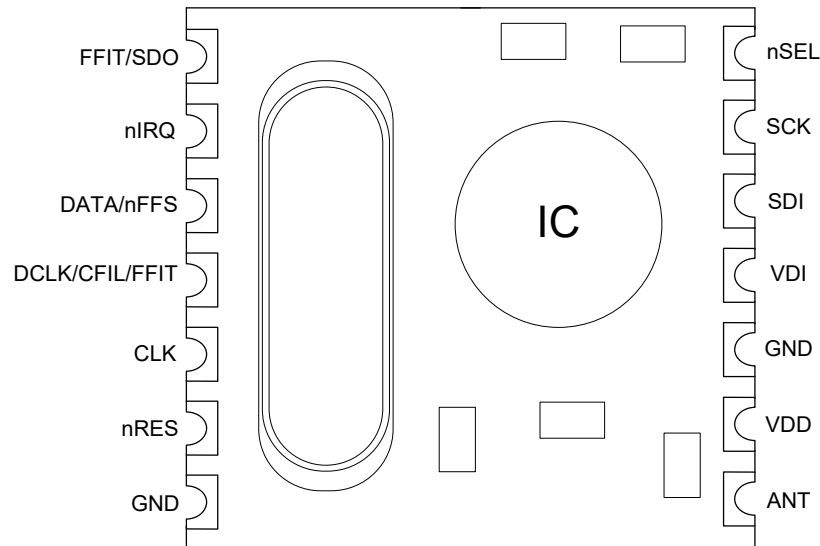

Pin	Definition	Direction	Description
1	FFIT/SDO	OUT	FIFO fill interrupt (Active Low) / status read data output
2	nIRQ	OUT	Interrupt Request Output (Active Low)
3	DATA/nFFS	IN	FSK Data Output (non FIFO Mode) / FIFO Select
4	DATA/CFIL/FFIT	IN/OUT	Clock Output (noFIFO) / External filter Capacitor(analog mode) / FIFO interrupt (active High) when FIFO level set to 1, FIFO Empty interruption can be achieved.
5	CLK	OUT	Clock out for MCU (1-10MHz)
6	nRES	IN	Reset Device
7	GND	-	Ground Connection
8	ANT	IN	Antenna input
9	VDD	IN	Positive Power Supply
10	GND	-	Ground Connection
11	VDI	OUT	Valid Data Indicator
12	SDI	IN	SPI Data Input
13	SCK	IN	SPI Clock Input
14	nSEL	IN	Chip select (Active Low)

## Transmitter Mechanical Dimensions

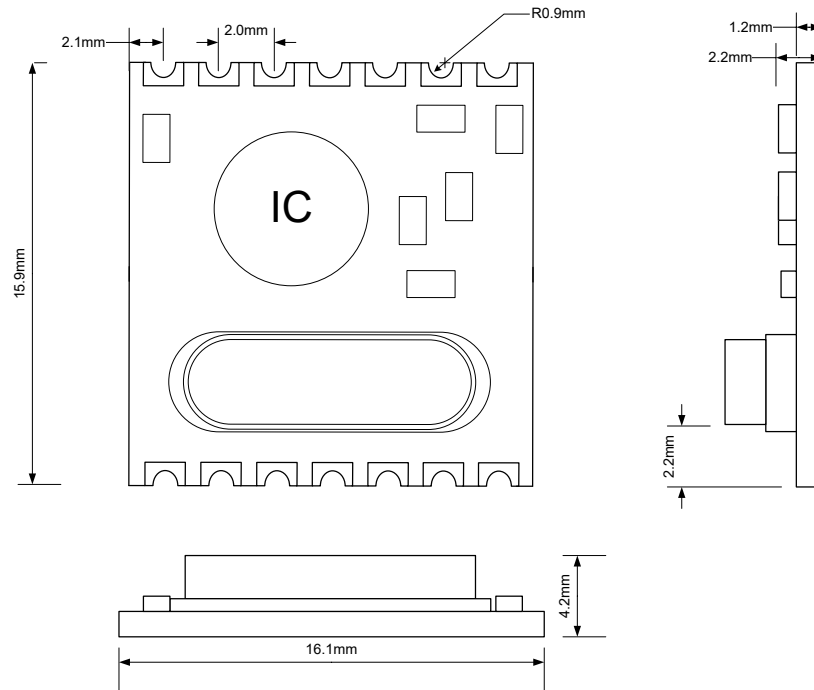

## Receiver Mechanical Dimensions

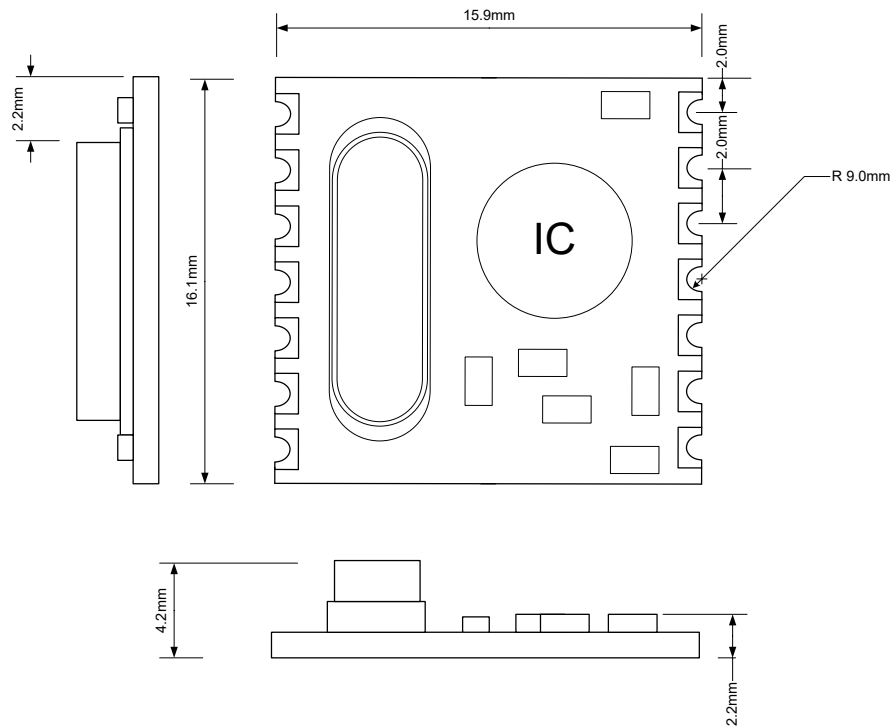

## Receiver Technical Specifications

### Maximum Ratings (not Operating)

Symbol	Parameter	Minimum	Maximum	Unit
V <sub>DD</sub>	Positive Supply	-0.5	6.0	V
V <sub>IN</sub>	All pin input level	-0.5	V <sub>DD</sub> +0.5	V
I <sub>IN</sub>	Input current except power	-25	+25	mA
T <sub>ST</sub>	Storage Temp	-55	125	°C
T <sub>ID</sub>	Soldering Temp		260	°C

### Maximum Working Range

Symbol	Parameter	Minimum	Maximum	Unit
V <sub>DD</sub>	Positive Supply	2.2	5.4	V
T <sub>OP</sub>	Operating Temp	-40	85	°C

### DC Characteristics

Symbol	Parameter	Min	Typical	Max	Unit
I <sub>DD</sub>	Current Consumption @ 433 @ 915		9	11	mA
			10.5	12.5	
I <sub>X</sub>	Stand by Current		3.0	3.5	mA
I <sub>PD</sub>	Sleep Mode Current		0.3		µA
I <sub>LB</sub>	Low Battery Detection		0.5		µA
V <sub>LB</sub>	Low Battery Step (0.1V steps)	2.2		5.3	V
V <sub>LBA</sub>	Low Battery accuracy		75		mV
V <sub>IL</sub>	Low Level Input			0.3 x V <sub>DD</sub>	V
V <sub>IH</sub>	High Level Input	0.7 x V <sub>DD</sub>			V
I <sub>IL</sub>	Leakage Current, V <sub>IL</sub> = 0V	-1		1	µA
I <sub>IH</sub>	Leakage Current, V <sub>IH</sub> = V <sub>DD</sub> , V <sub>DD</sub> = 5.4V	-1		1	µA
V <sub>OL</sub>	Low Level output, I <sub>OL</sub> = 2mA			0.4	V
V <sub>OH</sub>	High Level output, I <sub>OH</sub> = 2mA	V <sub>DD</sub> -0.4			V

### AC Characteristics

Symbol	Parameter	Min	Typical	Max	Unit	
F <sub>LO</sub>	Frequency @433MHz @915MHz	430.24		439.75	MHz	
		900.72		929.27		
BW	Bandwidth	1	60	67	75	KHz
		2	120	134	150	
		3	180	200	225	
		4	240	270	300	
		5	300	350	375	
		6	360	400	450	
T <sub>LOCK</sub>	PLL Lock time, after 10MHz step hopping.		20		µS	
T <sub>ST,P</sub>	PLL Start time, after crystal stabilised		250		µS	
BR	Data Rate			115.2	Kbps	
P <sub>MIN</sub>	Sensitivity @433MHz @915MHz		-109	-100	dBm	
			-105	-98		
RS <sub>A</sub>	RSSI Accuracy	-5		+5	dB	
RS <sub>R</sub>	RSSI Range		46		dB	
RS <sub>STEP</sub>	RSSI Programmable Step		6		dB	
RS <sub>ARSSI</sub>	ARSSI Filter		1		nF	
RS <sub>-RESP</sub>	DRSSI Response Time, C		500		µs	
C <sub>XL</sub>	Capacitor Bank	8.5		16	pF	
T <sub>POR</sub>	PWR time, power up time (V <sub>DD</sub> to 90%)		50	100	mS	
T <sub>PBT</sub>	Wake up timer period	.96		1.08	mS	
T <sub>-WAKEUP</sub>	Programmable Wake up time	1		5x10 <sup>11</sup>	mS	

## Transmitter Technical Specifications

### Maximum Ratings (not Operating)

Symbol	Parameter	Minimum	Maximum	Unit
V <sub>DD</sub>	Positive Supply	-0.5	6.0	V
V <sub>IN</sub>	All pin input level	-0.5	V <sub>DD</sub> +0.5	V
I <sub>IN</sub>	Input current except power	-25	+25	mA
T <sub>ST</sub>	Storage Temp	-55	125	°C
T <sub>ID</sub>	Soldering Temp		260	°C

### Maximum Working Range

Symbol	Parameter	Minimum	Maximum	Unit
V <sub>DD</sub>	Positive Supply	2.2	5.4	V
T <sub>OP</sub>	Operating Temp	-40	85	°C

### DC Characteristics

Symbol	Parameter	Minimum	Typical	Maximum	Unit
I <sub>DD</sub>	Current Consumption @ 433MHz @ 915MHz @ 0dBm Power output		12 15		mA
I <sub>DD</sub>	Current Consumption @ max power output		23		mA
I <sub>PD</sub>	Sleep Mode Current		0.3		uA
I <sub>WT</sub>	Wake up timer consumption		1.5		uA
I <sub>LB</sub>	Low Battery Detector Current		0.5		uA
I <sub>X</sub>	Idle Mode (crystal only)		1.5		mA
V <sub>LB</sub>	Low Battery Detect range (0.1V steps)	2.2		5.3	mV
V <sub>IL</sub>	Low Level Input			0.3 x V <sub>DD</sub>	V
V <sub>IH</sub>	High Level Input	0.7xV <sub>DD</sub>			V
I <sub>IL</sub>	Leakage Current, V <sub>IL</sub> = 0V	-1		1	uA
I <sub>IH</sub>	Leakage Current, V <sub>IH</sub> = V <sub>DD</sub> , V <sub>DD</sub> = 5.4V	-1		1	uA
V <sub>OL</sub>	Low Level output, I <sub>OL</sub> = 2mA			0.4	V
V <sub>OH</sub>	High Level output, I <sub>OH</sub> = 2mA	V <sub>DD</sub> -0.4			V

### AC Characteristics

Symbol	Parameter	Minimum	Typical	Maximum	Unit
F <sub>REF</sub>					
F <sub>O</sub>	Frequency @433MHz 2.5KHz Step @915MHz 7.5KHz Step	430.24 900.72		439.75 929.27	MHz
T <sub>LOCK</sub>	PLL Lock time, after 10Mhz step hopping.		20		uS
T <sub>SP</sub>	PLL Start time, after crystal stabilised			250	uS
P <sub>MAX</sub>	Max Available Power Output @433MHz @915MHz	5 2	7 4		dBm
Q <sub>O</sub>	Q Factor of Output capacitance	16	18	22	
BR <sub>FSK</sub>	FSK Data Rate			115.2	kbps
DF <sub>FSK</sub>	FSK Deviation, 30KHz step	30		210	KHz
T <sub>PBT</sub>	Period for Wake Up timer	0.95		1.05	mS
T <sub>WAKEUP</sub>	Wake Up Timer	1		2x10 <sup>9</sup>	mS
T <sub>POR</sub>	Power up time		100		mS

## Transmitter Programming Guide

### 1. Brief Description

The ALPHA Transmitter is a low cost FSK transmitter. It needs only an MCU, crystal, decoupling capacitor and antenna to build a high reliability FSK transmitter. The operation frequency can cover 300 to 1000MHz.

Control Command	Related Parameters/Functions		Related control bits
1	Configuration Setting Command	Frequency band, microcontroller clock output, crystal load capacitance, frequency deviation	b1 to b0, d2 to d0, x3 to x0, ms, m2 to m0
2	Power Management Command	Crystal oscillator, synthesizer, power amplifier, low battery detector, wake-up timer, clock output buffer	a1 a0, ex, es, ea, eb, et, dc
3	Frequency Setting Command	Carrier frequency	f11 to f0
4	Data Rate Command	Bit rate	r7 to r0
5	Power Setting Command	Nominal output power, OOK mode	ook, p2 to p0
6	Low Battery Detector Command	Low battery threshold limit, transmit bit synchronizer, wake-up timer calibration	dwc, ebs, t4 to t0
7	Sleep Command	Length of the clock tail after power down	s7 to s0
8	Push-Button Command	Push-button related functions	p4, d1 to d0, b4 to b1, bc
9	Wake-Up Timer Command	Wake-up time period	r4 to r0, m7 to m0
10	Data Transmit Command		Data transmission
11	Status Register Command		Transmitter status read
12	PLL Setting and Reset Mode Command	PLL bandwidth, reset mode	bw1 to bw0, dr

### 2. Commands

#### CONTROL INTERFACE

Commands to the transmitters are sent serially. Data bits on pin SDI are shifted into the device upon the rising edge of the clock on pin SCK whenever the chip select pin nSEL is low. When the nSEL signal is high, it initializes the serial interface. The number of bits sent is an integer multiple of 8. All commands consist of a command code, followed by a varying number of parameter or data bits. All data are sent MSB first (e.g. bit 15 for a 16-bit command). Bits having no influence (don't care) are indicated with X. The Power On Reset (POR) circuit sets default values in all control and command registers. The status information or received data can be read serially over the IRQ pin. Bits are shifted out upon the falling edge of CLK signal

#### Timing Specification

Symbol	Parameter	Minimum value [ns]
$t_{CH}$	Clock high time	25
$t_{CL}$	Clock low time	25
$t_{SS}$	Select setup time (nSEL falling edge to SCK rising edge)	10
$t_{SH}$	Select hold time (SCK falling edge to nSEL rising edge)	10
$t_{SHI}$	Select high time	25
$t_{DS}$	Data setup time (SDI transition to SCK rising edge)	5
$t_{DH}$	Data hold time (SCK rising edge to SDI transition)	5
$t_{OD}$	Data delay time	10
$t_{BL}$	Push-button input low time	25

## 1. Timing Diagram

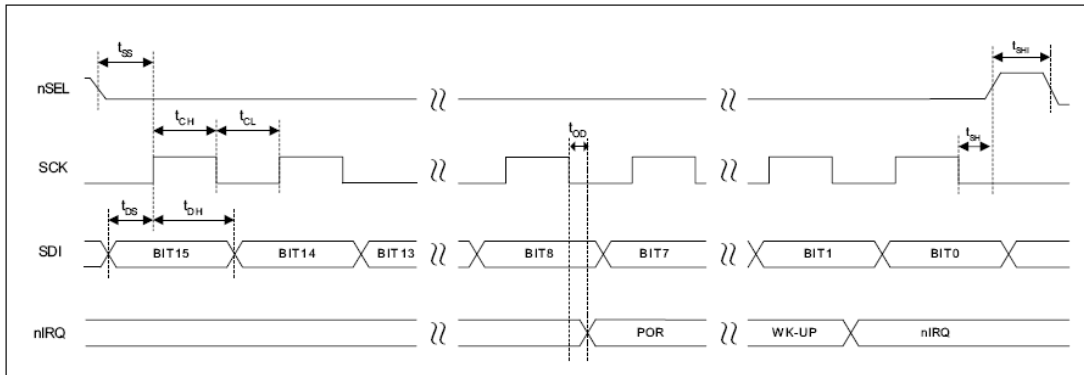

## 2. Configuration Setting Command

bit	15	14	13	12	11	10	9	8	7	6	5	4	3	2	1	0	POR
	1	0	0	b1	b0	d2	d1	d0	x3	x2	x1	x0	ms	m2	m1	m0	8080h

b1..b0: band select:

b1	b0	band[MHz]
0	1	433
1	0	868
1	1	915

d2..d0: select frequency of CLK pin

d2	d1	d0	CLK frequency[MHz]
0	0	0	1
0	0	1	1.25
0	1	0	1.66
0	1	1	2
1	0	0	2.5
1	0	1	3.33
1	1	0	5
1	1	1	10

CLK signal is derived from the crystal oscillator and can be applied to the MCU clock in to save a second crystal. If not used, please set bit "dc" to disable CLK output



x3..x0: select crystal load capacitor

x3	x2	x1	x0	Load capacitor [pF]
0	0	0	0	8.5
0	0	0	1	9.0
0	0	1	0	9.5
0	0	1	1	10.0
.....				.....
1	1	1	0	15.5
1	1	1	1	16.0

To integrate the load capacitor internal can not only save cost, but also adjust reference frequency by software.

ms: select modulation polarity

m2..m0: select frequency deviation

m2	m1	m0	Frequency deviation [kHz]
0	0	0	30
0	0	1	60
0	1	0	90
0	1	1	120
1	0	0	150
1	0	1	180
1	1	0	210

### 3. Power Management Command

bit	15	14	13	12	11	10	9	8	7	6	5	4	3	2	1	0	POR
	1	1	0	0	0	0	0	0	a1	a0	ex	es	ea	eb	et	dc	C000h

a1: Crystal oscillator and synthesizer are enabled by Data transmit Command and disable by Sleep command.

a0: Power amplifier is enabled by Data transmit Command and disable by Sleep Command.

ex: Enable crystal oscillator

es: Enable synthesizer

ea: Enable power amplifier

eb: Enable low battery detection function

et: Enable wake-up timer

### 4. Frequency Setting Command

bit	15	14	13	12	11	10	9	8	7	6	5	4	3	2	1	0	POR
	1	0	1	0	f11	f10	f9	f8	f7	f6	f5	f4	f3	f2	f1	f0	A7D0h

The 12-bit parameter of the Frequency Setting Command <f11- f0> has the value F. The value F should be in the range of 96 and 3903. When F is out of range, the previous value is kept. The synthesizer center frequency f0 can be calculated as:

$$f_0 = 10 \text{ MHz} * C1 * (C2 + F/4000)$$

The constants C1 and C2 are determined by the selected band as:

Band	C1	C2
315	1	31
433	1	43
868	2	43

## 5. Data Rate Command

bit	15	14	13	12	11	10	9	8	7	6	5	4	3	2	1	0	POR
	1	1	0	0	1	0	0	0	r7	r6	r5	r4	r3	r2	r1	r0	C800h

r7..r0: set data rate  
 $BR = 10000000 / 29 / (R + 1)$   
 BR is data rate

Apart from setting custom values, the standard bit rates from 2.4 to 115.2 kbps can be approximated with minimal error.

The commands are read out with a different fixed bit rate:

Fsk = 10 MHz / 29 / 3 [~115.2 kHz]

Note:

PLL bandwidth should be set according the data rate. Please see the PLL Setting Command

## 6. Power Setting Command

bit	7	6	5	4	3	2	1	0	POR
	1	0	1	1	0	p2	p1	p0	B0h

p2..p0: set relative output power:  
 $P_{out} = P_{max} - P * 3$  [dBm]  
 Pmax is the max output power; it is related to the antenna impedance.

## 7. Low Battery Detector and Tx bit Synchronization Command

bit	15	14	13	12	11	10	9	8	7	6	5	4	3	2	1	0	POR
	1	1	0	0	0	0	1	0	dwc	0	ebs	t4	t3	t2	t1	t0	C200h

dwc: Disable wake-up timer periodical calibration  
 ebs: Enable TX bit synchronization function  
 t4..t0: Set threshold voltage of Low battery detector  
 $V_{lb} = 2.2 + T * 0.1$  [V]

## 8. Sleep Command

bit	15	14	13	12	11	10	9	8	7	6	5	4	3	2	1	0	POR
	1	1	0	0	0	1	0	0	s7	s6	s5	s4	s3	s2	s1	s0	C400h

If crystal oscillator, synthesizer and power amplifier are auto-controlled, this command will close power amplifier and synthesizer immediately, then stop crystal oscillator after S periods of CLK signal

## 9. Wake-Up Timer Command

bit	15	14	13	12	11	10	9	8	7	6	5	4	3	2	1	0	POR
	1	1	1	r4	r3	r2	r1	r0	m7	m6	m5	m4	m3	m2	m1	m0	E000h

The wake-up timer period is determined by:  
 $T_{wake-up} = M * 2R$  [ms]  
 For continual operation, bit 'et' must be cleared and set

## 10. Data Transmit Command

bit	7	6	5	4	3	2	1	0
	1	1	0	0	0	1	1	0

This command indicate that the following data on SDI pin is to be transmitted, the transmission stops if nSel return to hi.

## 11. Status Register Read Com-

bit	15	14	13	12	11	10	9	8	7	6	5	4	3	2	1	0	POR
	1	1	0	0	1	1	0	0	0	0	0	0	0	0	0	0	--

With this command, it is possible to read the chip's status register through the nIRQ pin. This command clears the last serviced interrupt and processing the next pending one will start (if there is any).

## 12. PLL Setting and Reset Mode Command

15	14	13	12	11	10	9	8	7	6	5	4	3	2	1	0	POR
1	1	0	1	0	0	1	0	bw1	bw0	0	0	0	0	dr	0	D200h

Bits 7-6 <bw1 : bw0> select the PLL bandwidth:

Bw1	bw0	Max datarate [kbps]
0	1	19.2
1	1	38.4
0	0	68.9
1	0	115.2

Bit 1 (dr): Disables the highly sensitive RESET mode. If this bit is cleared, a 600 mV glitch in the power supply may cause a system reset. For more detailed description see the Reset modes section.

## 3. Transmitter Operation Flow

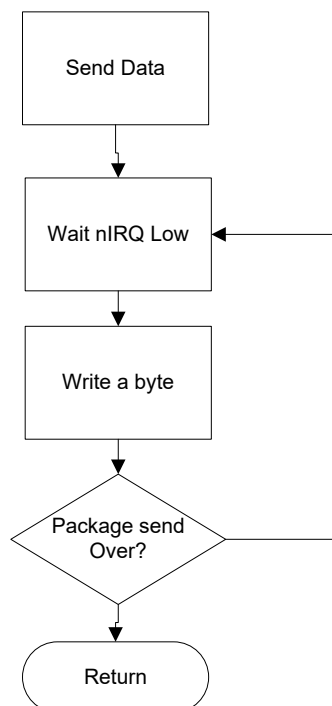
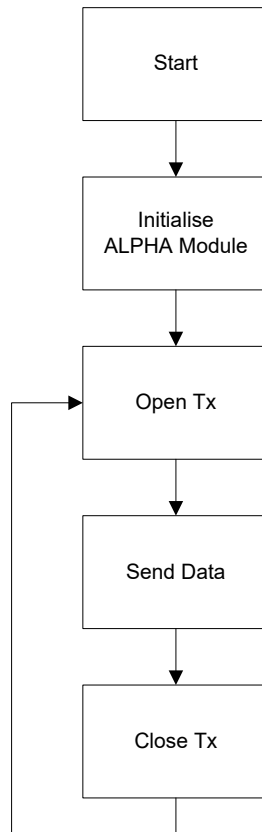

## Receiver Programming Guide

### 4. Brief Description

The ALPHA Receiver is a low cost FSK Receiver with all RF functions integrated. It needs only an MCU, crystal, decoupling capacitor and antenna to build a high reliability FSK transmitter. The operation frequency can cover 300 to 1000MHz. Although each module can cover all frequencies, better performance is obtained by using the module at the pre-set frequency. The module supports a command interface to setup frequency, deviation, output power and also data rate.

### 5. Commands

#### CONTROL INTERFACE

Commands to the transmitters are sent serially. Data bits on pin SDI are shifted into the device upon the rising edge of the clock on pin SCK whenever the chip select pin nSEL is low. When the nSEL signal is high, it initializes the serial interface. The number of bits sent is an integer multiple of 8. All commands consist of a command code, followed by a varying number of parameter or data bits. All data are sent MSB first (e.g. bit 15 for a 16-bit command). Bits having no influence (don't care) are indicated with X. The Power On Reset (POR) circuit sets default values in all control and command registers.

The status information or received data can be read serially over the IRQ pin. Bits are shifted out upon the falling edge of CLK signal (POR) circuit sets default values in all control and command registers.

The status information or received data can be read serially over the IRQ pin. Bits are shifted out upon the falling edge of CLK signal

#### Timing Specification

Symbol	Parameter	Minimum value [ns]
$t_{CH}$	Clock high time	25
$t_{CL}$	Clock low time	25
$t_{SS}$	Select setup time (nSEL falling edge to SCK rising edge)	10
$t_{SH}$	Select hold time (SCK falling edge to nSEL rising edge)	10
$t_{SHI}$	Select high time	25
$t_{DS}$	Data setup time (SDI transition to SCK rising edge)	5
$t_{DH}$	Data hold time (SCK rising edge to SDI transition)	5
$t_{OD}$	Data delay time	10
$t_{BL}$	Push-button input low time	25

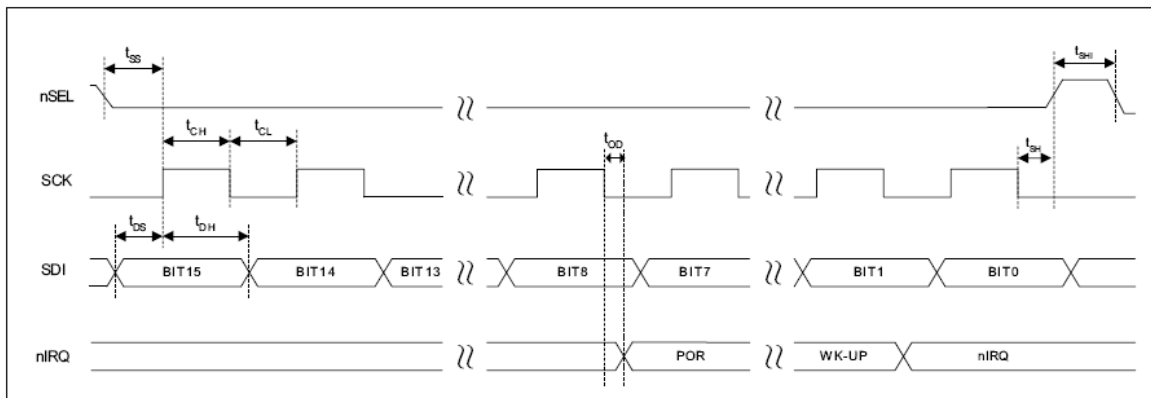

## 1. Configuration Setting Command

bit	15	14	13	12	11	10	9	8	7	6	5	4	3	2	1	0	POR
	1	0	0	b1	b0	eb	et	ex	x3	x2	x1	x0	i2	i1	i0	dc	893Ah

b1..b0: band select:

b1	b0	band[MHz]
0	0	315
0	1	433
1	0	868
1	1	915

eb: Enable low battery detection function

et: Enable wake-up timer

ex: Enable crystal oscillator

x3..x0: select crystal load capacitor

x3	x2	x1	x0	load capacitor [pF]
0	0	0	0	8.5
0	0	0	1	9.0
0	0	1	0	9.5
0	0	1	1	10.0
.....			.....	
1	1	1	0	15.5
1	1	1	1	16.0

i2..i0:select baseband bandwidth

i2	i1	i0	Baseband Bandwidth [kHz]
0	0	0	reserved
0	0	1	400
0	1	0	340
0	1	1	270
1	0	0	200
1	0	1	134
1	1	0	67
1	1	1	reserved

dc: Disable signal output of CLK pin

## 2. Frequency Setting Command

bit	15	14	13	12	11	10	9	8	7	6	5	4	3	2	1	0	POR
	1	0	1	0	f11	f10	f9	f8	f7	f6	f5	f4	f3	f2	f1	f0	A680h

f11..f0: Set operation frequency

The 12-bit parameter of the *Frequency Setting Command* <f11- f0> has the value F. The value F should be in the range of 96 and 3903. When F is out of range, the previous value is kept. The synthesizer center frequency f0 can be calculated as:

$$f0 = 10 \text{ MHz} * C1 * (C2 + F/4000)$$

The constants C1 and C2 are determined by the selected band as:

Band	C1	C2
315	1	31
433	1	43
868	2	43

## 3. Receiver Setting Command

bit	15	14	13	12	11	10	9	8	7	6	5	4	3	2	1	0	POR
	1	1	0	0	0	0	0	0	d1	d0	g1	g0	r2	r1	r0	en	C0C1h

d1..d0: select VDI source

d1	d0	VDI output
0	0	Digital RSSI output(DRSSI)
0	1	Data quality detection output (DQD)
1	0	Clock recovery lock output
1	1	DRSSI & DQD

g1..g0: select LNA gain

g1	g0	LNA gain (dBm)
0	0	0
0	1	-14
1	0	-6
1	1	-20

r2..r0: select DRSSI threshold

r2	r1	r0	RSSIsetth [dBm]
0	0	0	-103
0	0	1	-97
0	1	0	-91
0	1	1	-85
1	0	0	-79
1	0	1	-73
1	1	0	-67
1	0	1	-61

The actual DRSSI threshold is related to LNA setup:

$$RSSI_{th} = RSSI_{setth} + G_{LNA}$$

en: Enable the receiver

## 4. Wake-Up Timer Command

bit	15	14	13	12	11	10	9	8	7	6	5	4	3	2	1	0	POR
	1	1	1	r4	r3	r2	r1	r0	m7	m6	m5	m4	m3	m2	m1	m0	E196h

The wake-up period is determined by:

$$T_{wake-up} = M * 2^R \text{ [ms]}$$

For continual operation, bit 'et' must be cleared and set

## 5. Low Duty-Cycle Command

bit	15	14	13	12	11	10	9	8	7	6	5	4	3	2	1	0	POR
	1	1	0	0	1	1	0	0	d6	d5	d4	d3	d2	d1	d0	en	CCOEh

d6..d0: Set duty cycle D.C. =  $(D * 2 + 1) / M * 100\%$

en: Enable low duty cycle mode

## 6. Low Battery Detector and Microcontroller Clock Divider Command

bit	15	14	13	12	11	10	9	8	7	6	5	4	3	2	1	0	POR
	1	1	0	0	0	0	1	0	d2	d1	d0	t4	t3	t2	t1	t0	C200h

d2..d0: select frequency of CLK pin

d2	d1	d0	Clock frequency [MHz]
0	0	0	1
0	0	1	1.25
0	1	0	1.66
0	1	1	2
1	0	0	2.5
1	0	1	3.33
1	1	0	5
1	1	1	10

CLK signal is derive form crystal oscillator and it can be applied to MCU clock in to save a second crystal. If not used, please set bit "dc" to disable CLK output

To integrate the load capacitor internal can not only save cost, but also adjust reference frequency by software

t4..t0: Set threshold voltage of Low battery detector:  $V_{lb} = 2.2 + T * 0.1 \text{ [V]}$

## 7. AFC Command

bit	15	14	13	12	11	10	9	8	7	6	5	4	3	2	1	0	POR
	1	1	0	0	0	1	1	0	a1	a0	r11	r10	st	fi	oe	en	C6F7h



a1..a0: select AFC auto-mode:

a1	a0	
0	0	Controlled by MCU
0	1	Run once at power on
1	0	Keep offset when VDI hi
1	1	Keeps independently from VDI

r1..r0: select range limit

r1	r0	range (fres)
0	0	No restriction
0	1	+15/-16
1	0	+7/-8
1	1	+3-4

Freq

315 & 433band: 2.5kHz

868band: 5kHz

915band: 7.5kHz

st: st goes hi will store offset into output register

fi: Enable AFC hi accuracy mode

oe: Enable AFC output register

en: Enable AFC function

## 8. Data Filter Command

bit	15	14	13	12	11	10	9	8	7	6	5	4	3	2	1	0	POR
	1	1	0	0	0	1	0	0	al	ml	1	s1	s0	f2	f1	f0	C42Ch

al: Enable clock recovery auto-lock

ml: Enable clock recovery fast mode

s1..s0: select data filter type

s1	s0	Filter type
0	0	OOK
0	1	Digital filter
1	0	reserved

f1..f0: Set DQD threshold

## 9.

bit	15	14	13	12	11	10	9	8	7	6	5	4	3	2	1	0	POR
	1	1	0	0	1	0	0	0	cs	r6	r5	r4	r3	r2	r1	r0	C823h

The expected bit rate of the received data stream is determined by the 7-bit value R (bits r6 to r0) and the 1 bit cs.

$$BR = 10000000 / 29 / (R + 1) / (1 + cs * 7)$$

In the receiver set R according the next function:

$$R = (10 \text{ MHz} / 29 / (1 + cs * 7) / BR) - 1$$

Apart from setting custom values, the standard bit rates from 600 bps to 115.2 kbps can be approximated with small error.

## 10. Outputs and FIFO mode Command

bit	15	14	13	12	11	10	9	8	7	6	5	4	3	2	1	0	POR
	1	1	0	0	1	1	1	0	f3	f2	f1	f0	s1	s0	ff	fe	CE85h

f3..f0: Set FIFO interrupt level  
s1..s0: select FIFO fill start condition

s1	s0	
0	0	VDI
0	1	Sync-word
1	0	VDI & Sync-word
1	1	Always

ff: Enable FIFO fill  
fe: Enable FIFO function

## 11. Reset Mode Command

bit	15	14	13	12	11	10	9	8	7	6	5	4	3	2	1	0	POR
	1	1	0	1	1	0	1	0	0	0	0	0	0	0	0	dr	DA00h

Bit 0 (*dr*): Disables the highly sensitive RESET mode. If this bit is cleared, a 600 mV glitch in the power supply may cause a system reset. For a more detailed description see the *Reset modes* section.

## 12. Status Read Command

The read command starts with a zero, whereas all other control commands start with a one. Therefore, after receiving the first bit of the control command the module identifies it as a read command. So as the first bit of the command is received, the receiver starts to clock out the status bits on the SDO output as follows:-

FIFO IT	Number of the data bits in the FIFO is reached the preprogrammed limit
FFOV	FIFO overflow
WK-UP	Wake-up timer overflow
LBD	Low battery detect, the power supply voltage is below the preprogrammed limit
FFEM	FIFO is empty
DRSSI	The strength of the incoming signal is above the preprogrammed limit
DQD	Data Quality Detector detected a good quality signal
CRL	Clock recovery lock
ATGL	Toggleing in each AFC cycle
ASAME	AFC stabilized (measured twice the same offset value)
OFFS6, 4-0	Offset value to be added to the value of the Frequency control word

**Note:** The FIFO IT bit behaves like a status bit, but generates nIRQ pulse if active. To check whether there is a sufficient amount of data in the FIFO, the SDO output can be tested. In extreme speed critical applications, it can be useful to read only the first four bits (*FIFO IT - LBD*) to clear the FFOV, WK-UP, and LBD bits. During the FIFO access the fSCK cannot be higher than  $f_{ref} / 4$ , where  $f_{ref}$  is the crystal oscillator frequency. If the FIFO is read in this mode the nFFS input must be connected to logic high level.

## FIFO Buffered Data Read

In this operating mode, incoming data are clocked into a 16 bit FIFO buffer. The receiver starts to fill up the FIFO when the Valid Data Indicator (VDI) bit and/or the synchron word recognition circuit indicates potentially real incoming data. This prevents the FIFO from being filled with noise and overloading the external microcontroller.

For further details see the *Receiver Setting Command* and the *Output and FIFO Command*.

*Polling Mode:* The nFFS signal selects the buffer directly and its content could be clocked out through pin SDO by SCK. Set the FIFO IT level to 1. In this case, as long as FFIT indicates received bits in the FIFO, the controller may continue to take the bits away. When FFIT goes low, no more bits need to be taken. An SPI read command is also available.

*Interrupt Controlled Mode:*

The user can define the FIFO level (the number of received bits) which will generate the nFFIT when exceeded. The status bits report the changed FIFO status in this case.

# ALPHA RF Modules

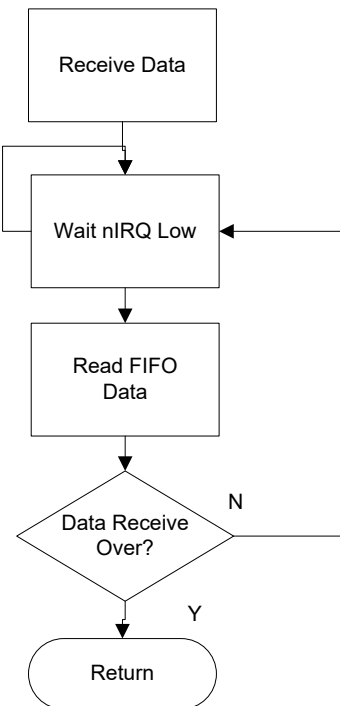
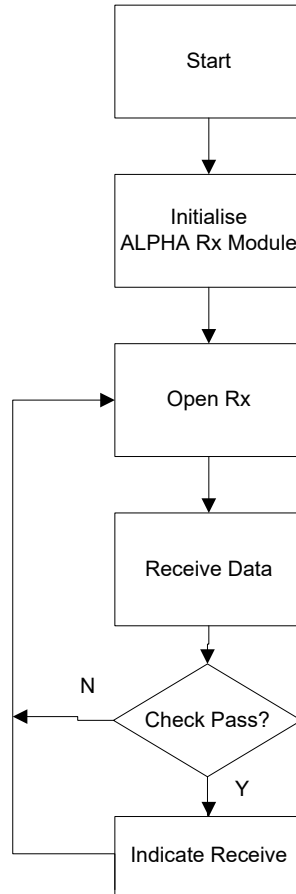

After Initialisation, open FIFO receive mode and wait for nIRQ low, only then can the MCU read received and stored data in FIFO.  
For the next received package please reset FIFO

## **Important European compliance information for module datasheets**

This RF Solutions radio module meets the essential requirements of the European Radio Equipment Directive 2014/53/EU and has been tested to European Harmonised Standards and CE marked accordingly. A copy of the EU Declaration of Conformity can be located on the RF Solutions Website, [www.rfsolutions.co.uk/certification-i59](http://www.rfsolutions.co.uk/certification-i59).

When using the module in an end product, continued compliance can only be assured by incorporating the module in accordance with RF Solutions specific installation instructions and in accordance with the published information on the RF Solutions product data sheet.

Where stated the antenna gain specification must be adhered to at all times.

Article 3.1a and 3.1b of the EU Radio Equipment Directive 2014/53/EU should be assessed in the final product.

Failure to follow this guidance may result in a non-compliant product being placed on the European Market, for which RF Solutions cannot accept any responsibility.

Further guidance may be obtained from RF Solutions Technical Support. Charges may apply to customer specific product evaluation.

November 2017

## Simplified Declaration of Conformity (RED)

**BG** - С настоящото RF Solutions Limited декларира, че този тип радиосъоръжение е дефинирано в този документ и е в съответствие с Директива 2014/53/ЕС. Цялостният текст на ЕС декларацията за съответствие може да се намери на следния интернет адрес: [www.rfsolutions.co.uk](http://www.rfsolutions.co.uk)

**CS** - Tímto RF Solutions Limited prohlašuje, že typ rádiového zařízení definované v tomto dokumentu je v souladu se směrnicí 2014/53/EU. Úplné znění EU prohlášení o shodě je k dispozici na této internetové adrese: [www.rfsolutions.co.uk](http://www.rfsolutions.co.uk)

**DA** - Hermed erklærer RF Solutions Limited, at radioudstyrstypen defineret i dette dokument er i overensstemmelse med direktiv 2014/53/EU. EU-overensstemmelseserklæringens fulde tekst kan findes på følgende internetadresse: [www.rfsolutions.co.uk](http://www.rfsolutions.co.uk)

**DE** - Hiermit erkläre RF Solutions Limited, dass der Funkanlagentyp in diesem Dokument definiert der Richtlinie 2014/53/EU entspricht. Der vollständige Text der EU-Konformitätserklärung ist unter der folgenden Internetadresse verfügbar: [www.rfsolutions.co.uk](http://www.rfsolutions.co.uk)

**EL** - Με την παρούσα ο/η RF Solutions Limited, δηλώνει ότι ο ραδιοεξοπλισμός ορίζεται σε αυτό το έγγραφο πληροί την οδηγία 2014/53/ΕΕ. Το πλήρες κείμενο της δήλωσης συμμόρφωσης ΕΕ διατίθεται στην ακόλουθη ιστοσελίδα στο διαδίκτυο: [www.rfsolutions.co.uk](http://www.rfsolutions.co.uk)

**EN** - Hereby, RF Solutions Limited declares that the radio equipment type defined within this document is in compliance with Directive 2014/53/EU. The full text of the EU declaration of conformity is available at the following internet address: [www.rfsolutions.co.uk](http://www.rfsolutions.co.uk)

**ES** - Por la presente, RF Solutions Limited declara que el tipo de equipo radioeléctrico definido dentro de este documento es conforme con la Directiva 2014/53/UE. El texto completo de la declaración UE de conformidad está disponible en la dirección Internet siguiente: [www.rfsolutions.co.uk](http://www.rfsolutions.co.uk)

**ET** - Käesolevaga deklareerib RF Solutions Limited, et käesolev raadioseadme tüüp määratletud selles dokumendis vastab direktiivi 2014/53/EL nõuetele. ELi vastavusdeklaratsiooni täielik tekst on kättesaadav järgmisel internetiaadressil: [www.rfsolutions.co.uk](http://www.rfsolutions.co.uk)

**FI** - RF Solutions Limited vakuuttaa, että radiolaitetyypin määratteutud selles dokumendis on direktiivin 2014/53/EU mukainen. EU-vaatimustenmukaisuusvakuutuksen täysimittainen teksti on saatavilla seuraavassa internetosoitteessa: [www.rfsolutions.co.uk](http://www.rfsolutions.co.uk)

**FR** - Le soussigné, RF Solutions Limited, déclare que l'équipement radioélectrique du type défini dans ce document est conforme à la directive 2014/53/UE. Le texte complet de la déclaration UE de conformité est disponible à l'adresse internet suivante: [www.rfsolutions.co.uk](http://www.rfsolutions.co.uk)

**HR** - RF Solutions Limited ovime izjavljuje da je radijska oprema tipa definirani u ovom dokumentu u skladu s Direktivom 2014/53/EU. Cjeloviti tekst EU izjave o sukladnosti dostupan je na sljedećoj internetskoj adresi: [www.rfsolutions.co.uk](http://www.rfsolutions.co.uk)

**HU** - RF Solutions Limited igazolja, hogy a dokumentumban meghatározottak szerint típusú rádióberendezés megfelel a 2014/53/EU irányelvnek. Az EU-megfelelésségi nyilatkozat teljes szövege elérhető a következő internetes címen: [www.rfsolutions.co.uk](http://www.rfsolutions.co.uk)

**IT** - Il fabbricante, RF Solutions Limited, dichiara che il tipo di apparecchiatura radio definito all'interno di questo documento è conforme alla direttiva 2014/53/UE. Il testo completo della dichiarazione di conformità UE è disponibile al seguente indirizzo Internet: [www.rfsolutions.co.uk](http://www.rfsolutions.co.uk)

**LT** - Aš, RF Solutions Limited, patvirtinu, kad radijo įrenginių tipas apibūžta šiame dokumente atitinka Direktyvą 2014/53/ES. Visas ES atitikties deklaracijos tekstas prieinamas šiuo interneto adresu: [www.rfsolutions.co.uk](http://www.rfsolutions.co.uk)

**LV** - Ar šo RF Solutions Limited deklarē, ka radioiekārtā kas definēts šajā dokumentā atbilst Direktīvai 2014/53/ES. Pilns ES atbilstības deklarācijas teksts ir pieejams šādā interneta vietnē: [www.rfsolutions.co.uk](http://www.rfsolutions.co.uk)

**MT** - B'dan, RF Solutions Limited, niddikjara li dan it-tip ta' tagħmir tar-radju definit f'dan id-dokument huwa konformi mad-Direttiva 2014/53/UE. It-test kollu tad-dikjarazzjoni ta' konformità tal-UE huwa disponibbli f'dan l-indirizz tal-Internet li ġej: [www.rfsolutions.co.uk](http://www.rfsolutions.co.uk)

**NL** - Hierbij verklaar ik, RF Solutions Limited, dat het type radioapparatuur gedefinieerd in dit document conform is met Richtlijn 2014/53/EU. De volledige tekst van de EU-conformiteitsverklaring kan worden geraadpleegd op het volgende internetadres: [www.rfsolutions.co.uk](http://www.rfsolutions.co.uk)

**PL** - RF Solutions Limited niniejszym oświadczam, że typ urządzenia radiowego zdefiniowane w tym dokumencie jest zgodny z dyrektywą 2014/53/UE. Pełny tekst deklaracji zgodności UE jest dostępny pod następującym adresem internetowym: [www.rfsolutions.co.uk](http://www.rfsolutions.co.uk)

**PT** - O(a) abaixo assinado(a) RF Solutions Limited declara que o presente tipo de equipamento de rádio definido neste documento está em conformidade com a Diretiva 2014/53/UE. O texto integral da declaração de conformidade está disponível no seguinte endereço de Internet: [www.rfsolutions.co.uk](http://www.rfsolutions.co.uk)

**RO** - Prin prezenta, RF Solutions Limited declară că tipul de echipamente radio definit în acest document este în conformitate cu Directiva 2014/53/UE. Textul integral al declarației UE de conformitate este disponibil la următoarea adresă internet: [www.rfsolutions.co.uk](http://www.rfsolutions.co.uk)

**SK** - RF Solutions Limited týmto vyhlasuje, že rádiové zariadenie typu definované v tomto dokumente je v súlade so smernicou 2014/53/EÚ. Úplné EÚ vyhlásenie o zhode je k dispozícii na tejto internetovej adrese: [www.rfsolutions.co.uk](http://www.rfsolutions.co.uk)

**SL** - RF Solutions Limited potrjuje, da je tip radijske opreme opredeljeno v tem dokumentu skladen z Direktivo 2014/53/EU. Celotno besedilo izjave EU o skladnosti je na voljo na naslednjem spletnem naslovu: [www.rfsolutions.co.uk](http://www.rfsolutions.co.uk)

**SV** - Härmed försäkras RF Solutions Limited att denna typ av radioutrustning definieras i detta dokument överensstämmer med direktiv 2014/53/EU. Den fullständiga texten till EU-försäkran om överensstämmelse finns på följande webbadress: [www.rfsolutions.co.uk](http://www.rfsolutions.co.uk)

### RF Solutions Ltd. Recycling Notice

Meets the following EC Directives:

#### DO NOT

Discard with normal waste, please recycle.

#### ROHS Directive 2011/65/EU and amendment 2015/863/EU

Specifies certain limits for hazardous substances.

#### WEEE Directive 2002/96/EC

Waste electrical & electronic equipment. This product must be disposed of through a licensed WEEE collection point. RF Solutions Ltd., fulfills its WEEE obligations by membership of an approved compliance scheme.

Environment Agency producer registration number: WEE/JB0104WV.

### Waste Batteries and Accumulators Directive 2006/66/EC

Where batteries are fitted, before recycling the product, the batteries must be removed and disposed of at a licensed collection point.

#### Disclaimer:

Whilst the information in this document is believed to be correct at the time of issue, RF Solutions Ltd does not accept any liability whatsoever for its accuracy, adequacy or completeness. No express or implied warranty or representation is given relating to the information contained in this document. RF Solutions Ltd reserves the right to make changes and improvements to the product(s) described herein without notice. Buyers and other users should determine for themselves the suitability of any such information or products for their own particular requirements or specification(s). RF Solutions Ltd shall not be liable for any loss or damage caused as a result of user's own determination of how to deploy or use RF Solutions Ltd's products. Use of RF Solutions Ltd products or components in life support and/or safety applications is not authorised except with express written approval. No licences are created, implicitly or otherwise, under any of RF Solutions Ltd's intellectual property rights. Liability for loss or damage resulting or caused by reliance on the information contained herein or from the use of the product (including liability resulting from negligence or where RF Solutions Ltd was aware of the possibility of such loss or damage arising) is excluded. This will not operate to limit or restrict RF Solutions Ltd's liability for death or personal injury resulting from its negligence.