

8Mb SYNCBURST™ SRAM

MT58L512L18F, MT58L256L32F,
MT58L256L36F; MT58L512V18F,
MT58L256V32F, MT58L256V36F

3.3V V_{DD}, 3.3V or 2.5V I/O, Flow-Through

FEATURES

- Fast clock and OE# access times
- Single +3.3V +0.3V/-0.165V power supply (V_{DD})
- Separate +3.3V or +2.5V isolated output buffer supply (V_{DDQ})
- SNOOZE MODE for reduced-power standby
- Common data inputs and data outputs
- Individual BYTE WRITE control and GLOBAL WRITE
- Three chip enables for simple depth expansion and address pipelining
- Clock-controlled and registered addresses, data I/Os and control signals
- Internally self-timed WRITE cycle
- Burst control (interleaved or linear burst)
- Automatic power-down for portable applications
- 100-pin TQFP package
- 165-pin FBGA
- Low capacitive bus loading
- x18, x32, and x36 versions available

OPTIONS

- Timing (Access/Cycle/MHz)
 - 7.5ns/8.8ns/113 MHz
 - 8.5ns/10ns/100 MHz
 - 10ns/15ns/66 MHz
- Configurations
 - 3.3V I/O
 - 512K x 18
 - 256K x 32
 - 256K x 36
 - 2.5V I/O
 - 512K x 18
 - 256K x 32
 - 256K x 36
- Packages
 - 100-pin TQFP (2-chip enable)
 - 100-pin TQFP (3-chip enable)
 - 165-pin, 13mm x 15mm FBGA
- Operating Temperature Range
 - Commercial (0°C to +70°C)
 - Industrial (-40°C to +85°C)**

MARKING

-7.5
-8.5
-10

MT58L512L18F
MT58L256L32F
MT58L256L36F

MT58L512V18F
MT58L256V32F
MT58L256V36F

T
S
F*

None
IT

Part Number Example:

MT58L256V36FT-10

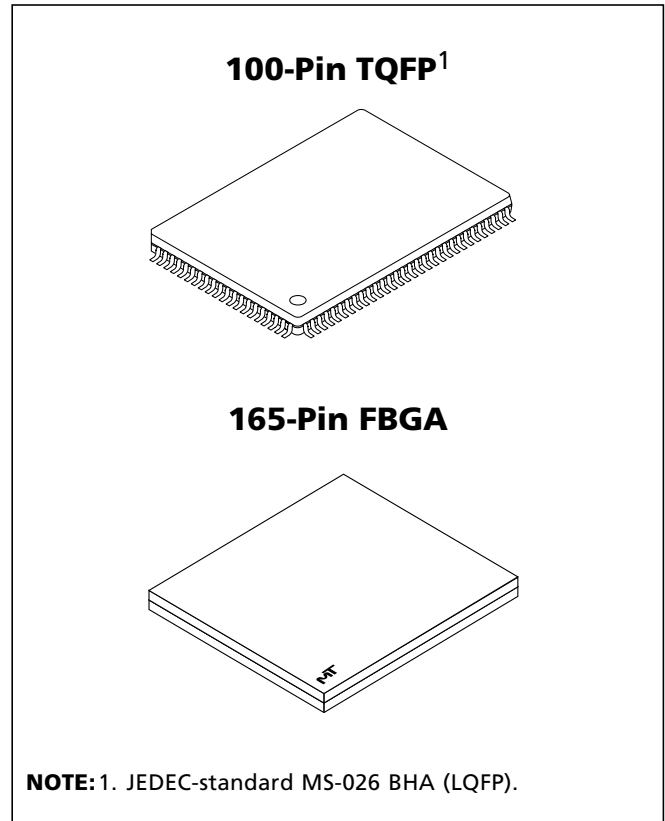

* A Part Marking Guide for the FBGA devices can be found on Micron's Website—<http://www.micron.com/support/index.html>.

** Industrial temperature range offered in specific speed grades and configurations. Contact factory for more information.

GENERAL DESCRIPTION

The Micron® SyncBurst™ SRAM family employs high-speed, low-power CMOS designs that are fabricated using an advanced CMOS process.

Micron's 8Mb SyncBurst SRAMs integrate a 512K x 18, 256K x 32, or 256K x 36 SRAM core with advanced synchronous peripheral circuitry and a 2-bit burst counter. All synchronous inputs pass through registers controlled by a positive-edge-triggered single-clock input (CLK). The synchronous inputs include all addresses, all data inputs, active LOW chip enable (CE#), two additional chip enables for easy depth expansion (CE2#, CE2), burst control inputs (ADSC#, ADSP#, ADV#), byte write

**FUNCTIONAL BLOCK DIAGRAM
512K X 18**

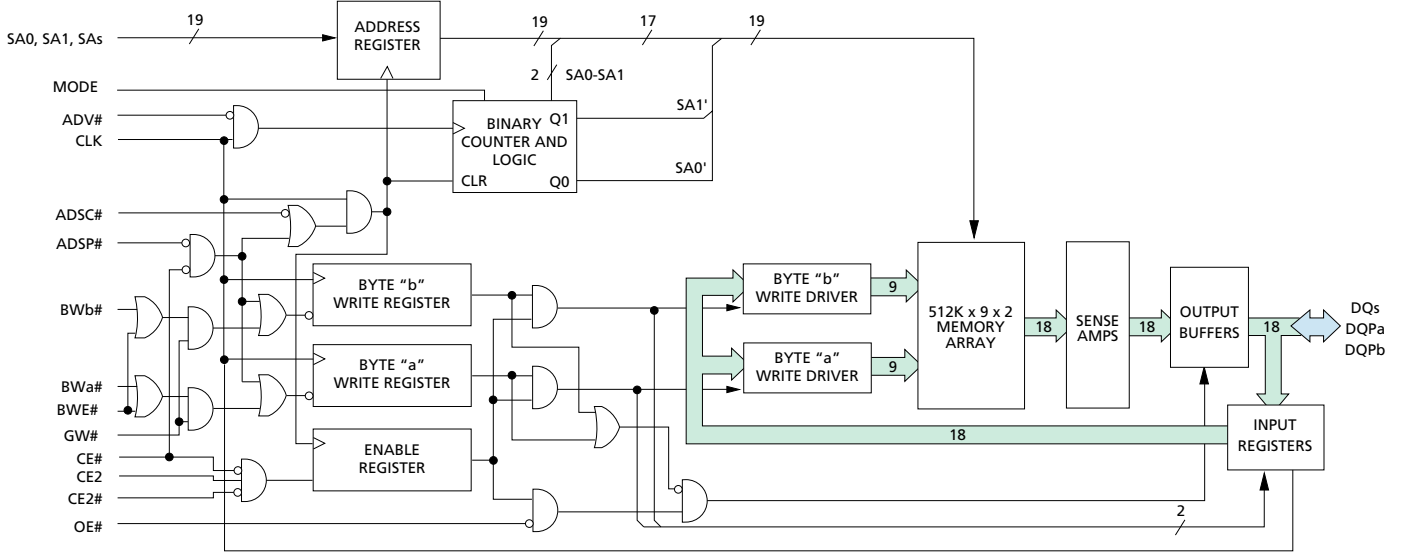

**FUNCTIONAL BLOCK DIAGRAM
256K X 32/36**

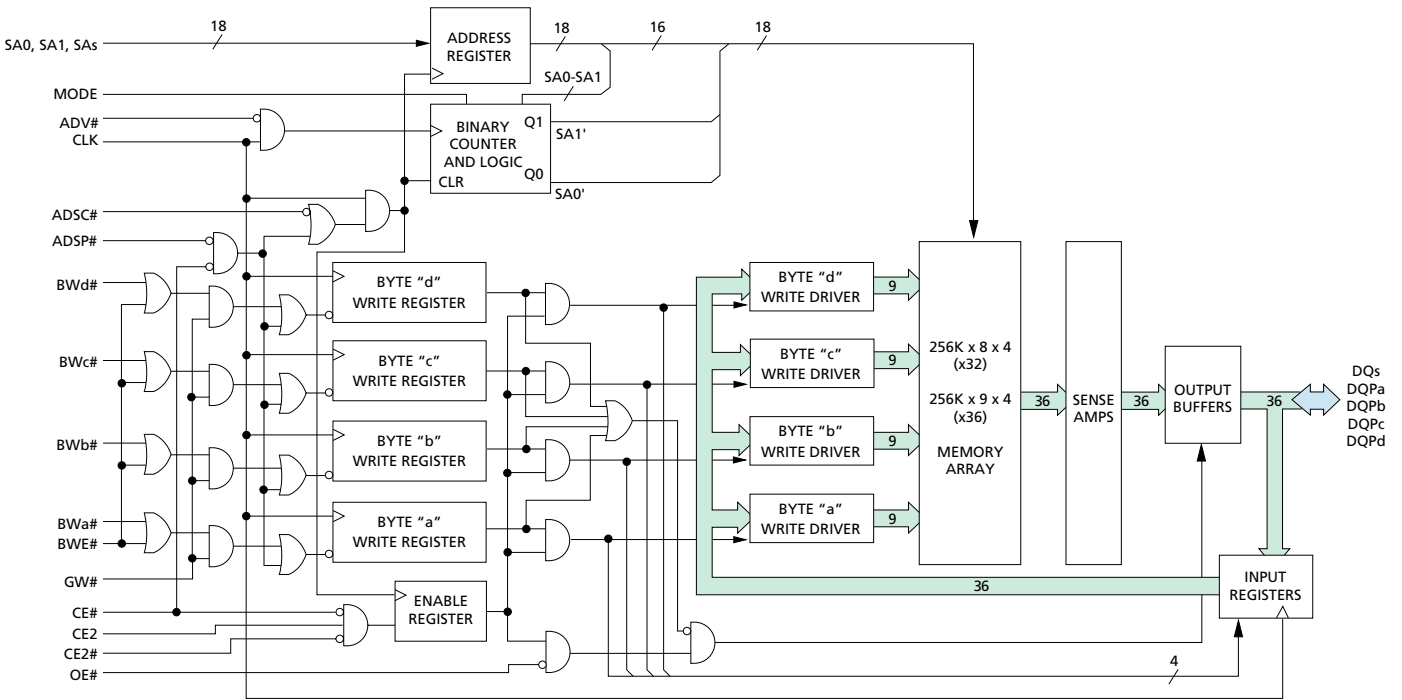

NOTE: Functional Block Diagrams illustrate simplified device operation. See Truth Table, Pin Descriptions, and timing diagrams for detailed information.

GENERAL DESCRIPTION (continued)

enables (BWx#) and global write (GW#). Note that CE2# is not available on the T Version.

Asynchronous inputs include the output enable (OE#), clock (CLK) and snooze enable (ZZ). There is also a burst mode input (MODE) that selects between interleaved and linear burst modes. The data-out (Q), enabled by OE#, is also asynchronous. WRITE cycles can be from one to two bytes wide (x18) or from one to four bytes wide (x32/x36), as controlled by the write control inputs.

Burst operation can be initiated with either address status processor (ADSP#) or address status controller (ADSC#) inputs. Subsequent burst addresses can be internally generated as controlled by the burst advance input (ADV#).

Address and write control are registered on-chip to simplify WRITE cycles. This allows self-timed WRITE cycles. Individual byte enables allow individual bytes to be written. During WRITE cycles on the x18 device, BWA# controls DQa pins and DQP_a; BWb# controls DQb pins and DQP_b. During WRITE cycles on the x32 and x36

devices, BWA# controls DQa pins and DQP_a; BWb# controls DQb pins and DQP_b; BWc# controls DQc pins and DQP_c; BWD# controls DQd pins and DQP_d. GW# LOW causes all bytes to be written. Parity bits are only available on the x18 and x36 versions.

Micron's 8Mb SyncBurst SRAMs operate from a +3.3V V_{DD} power supply, and all inputs and outputs are TTL-compatible. Users can choose either a 3.3V or 2.5V I/O version. The device is ideally suited for 486, Pentium®, 680x0 and PowerPC systems and those systems that benefit from a wide synchronous data bus. The device is also ideal in generic 16-, 18-, 32-, 36-, 64-, and 72-bit-wide applications.

Please refer to Micron's Web site (www.micron.com/sramds) for the latest data sheet.

TQFP PINOUTS

At the time of the writing of this data sheet, there are two pinouts in the industry. Micron will support both pinouts for this part.



TQFP PIN ASSIGNMENT TABLE

PIN #	x18	x32/x36
1	NC	NF/DQPc*
2	NC	DQc
3	NC	DQc
4	V _{DDQ}	
5	V _{SS}	
6	NC	DQc
7	NC	DQc
8	DQb	DQc
9	DQb	DQc
10	V _{SS}	
11	V _{DDQ}	
12	DQb	DQc
13	DQb	DQc
14	V _{SS}	
15	V _{DD}	
16	NC	
17	V _{SS}	
18	DQb	DQd
19	DQb	DQd
20	V _{DDQ}	
21	V _{SS}	
22	DQb	DQd
23	DQb	DQd
24	DQPb	DQd
25	NC	DQd

PIN #	x18	x32/x36
26	V _{SS}	
27	V _{DDQ}	
28	NC	DQd
29	NC	DQd
30	NC	NF/DQPd*
31	SA	
32		
33		
34		
35		
36		
37		
38		
39		
40		
41		
42		
43		
44		
45		
46		
47		
48		
49		
50		

PIN #	x18	x32/x36
51	NC	NF/DQPa*
52	NC	DQa
53	NC	DQa
54	V _{DDQ}	
55	V _{SS}	
56	NC	DQa
57	NC	DQa
58	DQa	
59	DQa	
60	V _{SS}	
61	V _{DDQ}	
62	DQa	
63	DQa	
64	ZZ	
65	V _{DD}	
66	NC	
67	V _{SS}	
68	DQa	DQb
69	DQa	DQb
70	V _{DDQ}	
71	V _{SS}	
72	DQa	DQb
73	DQa	DQb
74	DQPa	DQb
75	NC	DQb

PIN #	x18	x32/x36
76	V _{SS}	
77	V _{DDQ}	
78	NC	DQb
79	NC	DQb
80	SA	NF/DQPb*
81	SA	
82	SA	
83	ADV#	
84	ADSP#	
85	ADSC#	
86	OE#	
87	BWE#	
88	GW#	
89	CLK	
90	V _{SS}	
91	V _{DD}	
92	SA (T Version) CE2# (S Version)	
93	BWA#	
94	BWB#	
95	NC	BWc#
96	NC	BWd#
97	CE2	
98	CE#	
99	SA	
100	SA	

*No Function (NF) is used on the x32 version. Parity (DQPx) is used on the x36 version.

**PIN ASSIGNMENT (TOP VIEW)
100-PIN TQFP, 2-CHIP ENABLE,
T VERSION**

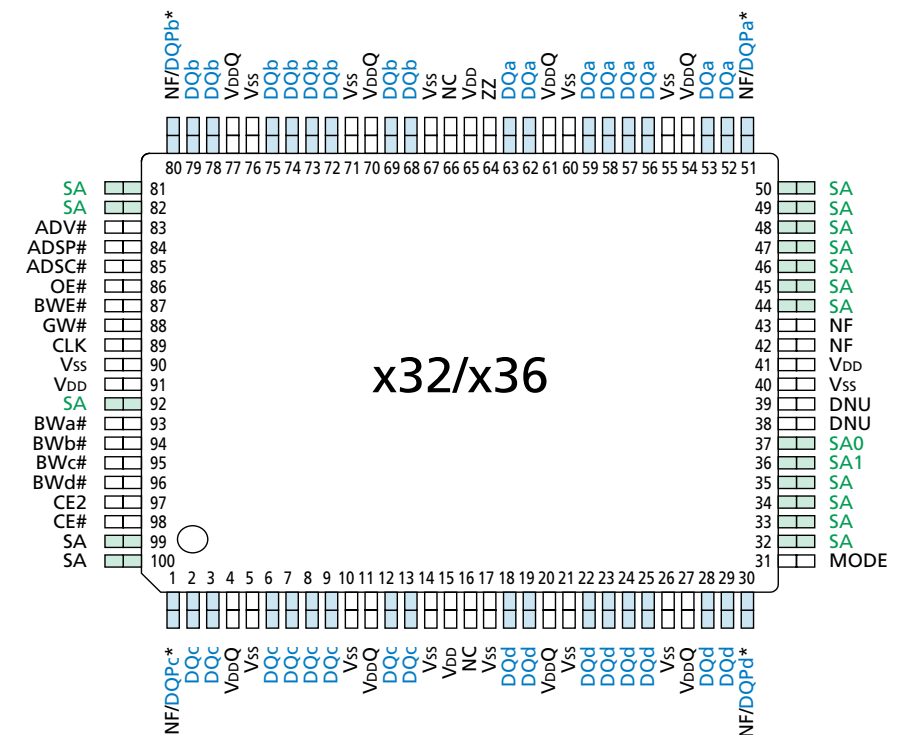
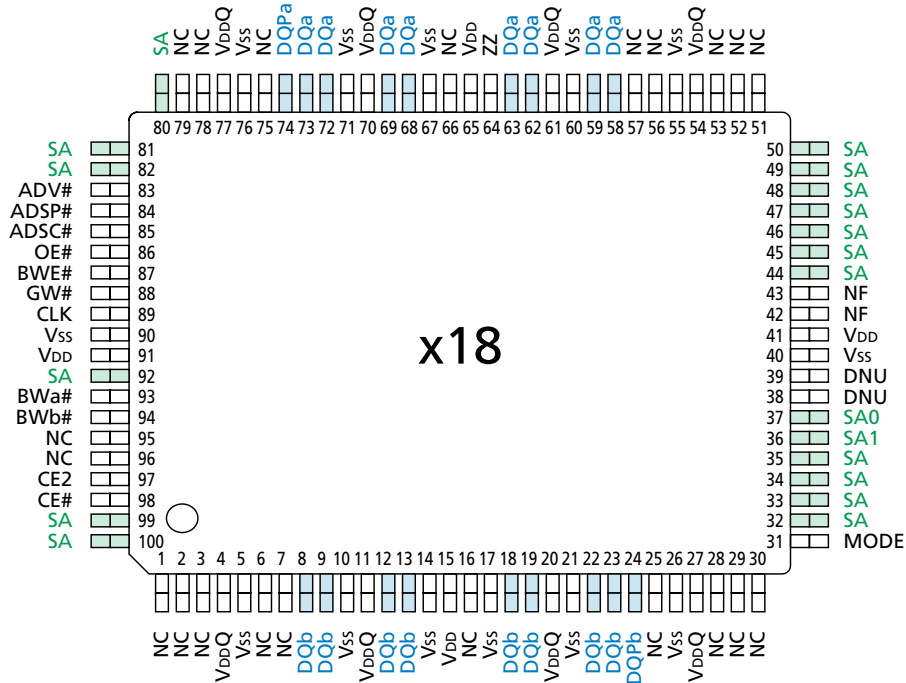

*No Function (NF) is used on the x32 version. Parity (DQPx) is used on the x36 version.

TQFP PIN DESCRIPTIONS

x18	x32/x36	SYMBOL	TYPE	DESCRIPTION
37 36 32-35, 44-50, 80-82, 99, 100 92 (T Version) 43 (S Version)	37 36 32-35, 44-50, 81, 82, 99, 100 92 (T Version) 43 (S Version)	SA0 SA1 SA	Input	Synchronous Address Inputs: These inputs are registered and must meet the setup and hold times around the rising edge of CLK. Two different pinouts are available for the TQFP package.
93 94 – –	93 94 95 96	BWa# BWB# BWC# BWD#	Input	Synchronous Byte Write Enables: These active LOW inputs allow individual bytes to be written and must meet the setup and hold times around the rising edge of CLK. A byte write enable is LOW for a WRITE cycle and HIGH for a READ cycle. For the x18 version, BWa# controls DQa pins and DQP _a ; BWb# controls DQb pins and DQP _b . For the x32 and x36 versions, BWa# controls DQa pins and DQP _a ; BWb# controls DQb pins and DQP _b ; BWC# controls DQc pins and DQP _c ; BWD# controls DQd pins and DQP _d . Parity is only available on the x18 and x36 versions.
87	87	BWE#	Input	Byte Write Enable: This active LOW input permits BYTE WRITE operations and must meet the setup and hold times around the rising edge of CLK.
88	88	GW#	Input	Global Write: This active LOW input allows a full 18-, 32- or 36-bit WRITE to occur independent of the BWE# and BWx# lines and must meet the setup and hold times around the rising edge of CLK.
89	89	CLK	Input	Clock: CLK registers address, data, chip enable, byte write enables and burst control inputs on its rising edge. All synchronous inputs must meet setup and hold times around the clock's rising edge.
98	98	CE#	Input	Synchronous Chip Enable: This active LOW input is used to enable the device and conditions the internal use of ADSP#. CE# is sampled only when a new external address is loaded.
92 (S Version)	92 (S Version)	CE2#	Input	Synchronous Chip Enable: This active LOW input is used to enable the device and is sampled only when a new external address is loaded. CE2# is only available on the S Version.
97	97	CE2	Input	Synchronous Chip Enable: This active HIGH input is used to enable the device and is sampled only when a new external address is loaded.
86	86	OE#	Input	Output Enable: This active LOW, asynchronous input enables the data I/O output drivers.
83	83	ADV#	Input	Synchronous Address Advance: This active LOW input is used to advance the internal burst counter, controlling burst access after the external address is loaded. A HIGH on this pin effectively causes wait states to be generated (no address advance). To ensure use of correct address during a WRITE cycle, ADV# must be HIGH at the rising edge of the first clock after an ADSP# cycle is initiated.
85	85	ADSC#	Input	Synchronous Address Status Controller: This active LOW input interrupts any ongoing burst, causing a new external address to be registered. A READ or WRITE is performed using the new address if CE# is LOW. ADSC# is also used to place the chip into power-down state when CE# is HIGH.

TQFP PIN DESCRIPTIONS (CONTINUED)

x18	x32/x36	SYMBOL	TYPE	DESCRIPTION
84	84	ADSP#	Input	Synchronous Address Status Processor: This active LOW input interrupts any ongoing burst, causing a new external address to be registered. A READ is performed using the new address, independent of the byte write enables and ADSC#, but dependent upon CE#, CE2 and CE2#. ADSP# is ignored if CE# is HIGH. Power-down state is entered if CE2 is LOW or CE2# is HIGH.
31	31	MODE	Input	Mode: This input selects the burst sequence. A LOW on this pin selects "linear burst." NC or HIGH on this pin selects "interleaved burst." Do not alter input state while device is operating.
64	64	ZZ	Input	Snooze Enable: This active HIGH, asynchronous input causes the device to enter a low-power standby mode in which all data in the memory array is retained. When ZZ is active, all other inputs are ignored.
(a) 58, 59, 62, 63, 68, 69, 72, 73 (b) 8, 9, 12, 13, 18, 19, 22, 23	(a) 52, 53, 56-59, 62, 63 (b) 68, 69, 72-75, 78, 79 (c) 2, 3, 6-9, 12, 13 (d) 18, 19, 22-25, 28, 29	DQa DQb DQc DQd	Input/ Output	SRAM Data I/Os: For the x18 version, Byte "a" is DQa pins; Byte "b" is DQb pins. For the x32 and x36 versions, Byte "a" is DQa pins; Byte "b" is DQb pins; Byte "c" is DQc pins; Byte "d" is DQd pins. Input data must meet setup and hold times around the rising edge of CLK.
74 24 – –	51 80 1 30	NF/DQPa NF/DQPb NF/DQPc NF/DQPd	NF/ I/O	No Function/Parity Data I/Os: On the x32 version, these pins are No Function (NF). On the x18 version, Byte "a" parity is DQPa; Byte "b" parity is DQPb. On the x36 version, Byte "a" parity is DQPa; Byte "b" parity is DQPb; Byte "c" parity is DQPc; Byte "d" parity is DQPd.
15, 41, 65, 91	15, 41, 65, 91	V _{DD}	Supply	Power Supply: See DC Electrical Characteristics and Operating Conditions for range.
4, 11, 20, 27, 54, 61, 70, 77	4, 11, 20, 27, 54, 61, 70, 77	V _{DDQ}	Supply	Isolated Output Buffer Supply: See DC Electrical Characteristics and Operating Conditions for range.
5, 10, 14, 17, 21, 26, 40, 55, 60, 67, 71, 76, 90	5, 10, 14, 17, 21, 26, 40, 55, 60, 67, 71, 76, 90	V _{SS}	Supply	Ground: GND.
38, 39	38, 39	DNU	–	Do Not Use: These signals may either be unconnected or wired to GND to improve package heat dissipation.
1-3, 6, 7, 16, 25, 28-30, 51-53, 56, 57, 66, 75, 78, 79, 95, 96	16, 66	NC	–	No Connect: These signals are not internally connected and may be connected to ground to improve package heat dissipation.
42 43 (T Version)	42 43 (T Version)	NF	–	No Function: These pins are internally connected to the die and have the capacitance of an input pin. It is allowable to leave these pins unconnected or driven by signals. On the S Version, pin 42 is reserved as an address upgrade pin for the 16Mb SyncBurst SRAM.

**PIN LAYOUT (TOP VIEW)
165-PIN FBGA**

x18

x32/x36

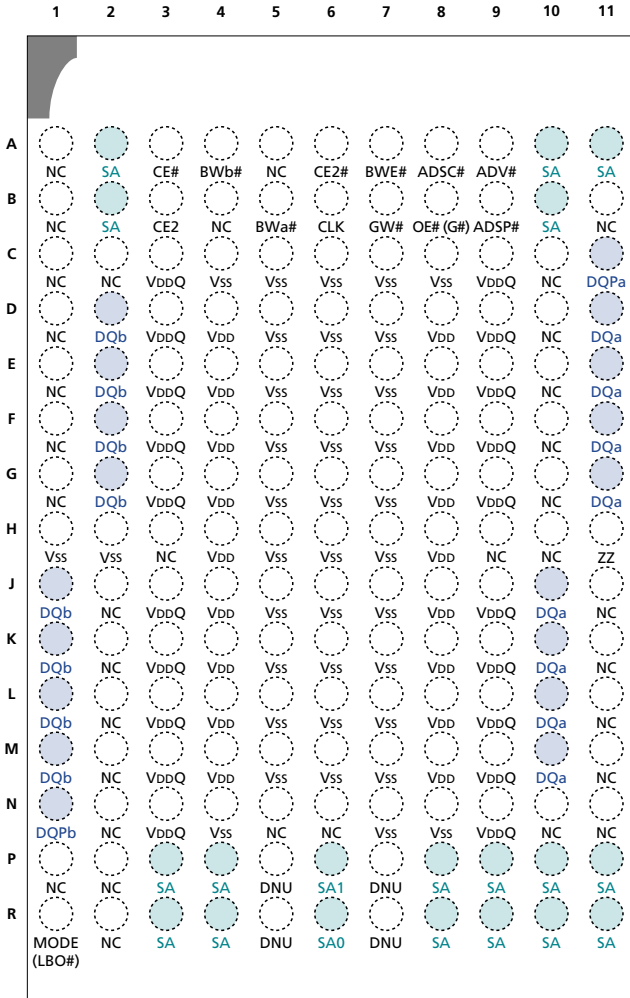

TOP VIEW

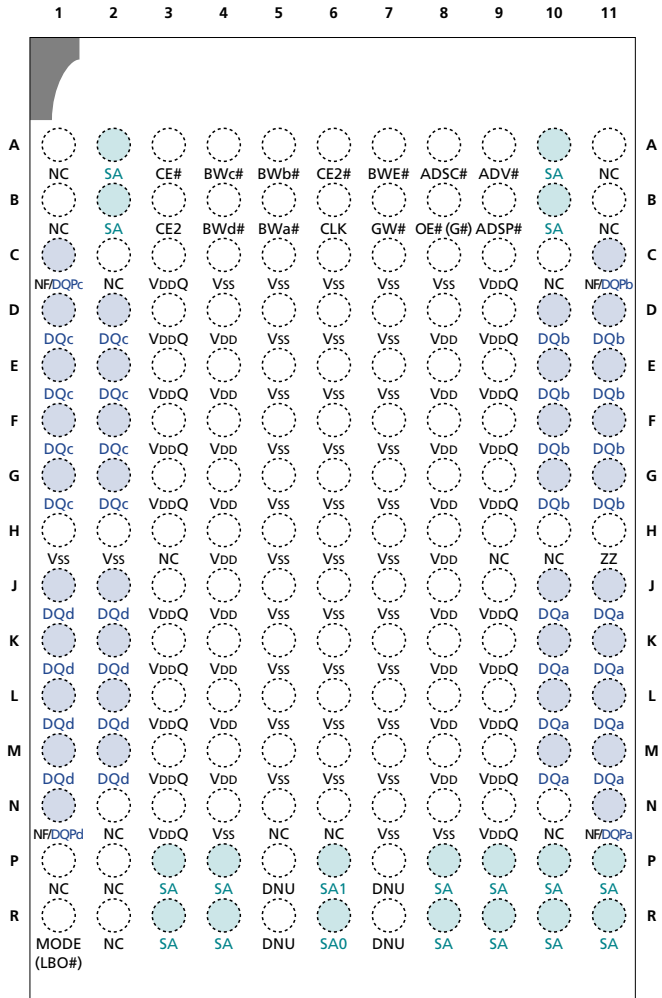

TOP VIEW

*No Function (NF) is used on the x32 version. Parity (DQP_x) is used on the x36 version.

NOTE: Pin 6N reserved for address pin expansion; 18Mb.

FBGA PIN DESCRIPTIONS

x18	x32/x36	SYMBOL	TYPE	DESCRIPTION
6R 6P 2A, 2B, 3P, 3R, 4P, 4R, 8P, 8R, 9P, 9R, 10A, 10B, 10P, 10R, 11A, 11P, 11R	6R 6P 2A, 2B, 3P, 3R, 4P, 4R, 8P, 8R, 9P, 9R, 10A, 10B, 10P, 10R, 11P, 11R	SA0 SA1 SA	Input	Synchronous Address Inputs: These inputs are registered and must meet the setup and hold times around the rising edge of CLK.
5B 4A – –	5B 5A 4A 4B	BWa# BWb# BWc# BWD#	Input	Synchronous Byte Write Enables: These active LOW inputs allow individual bytes to be written and must meet the setup and hold times around the rising edge of CLK. A byte write enable is LOW for a WRITE cycle and HIGH for a READ cycle. For the x18 version, BWa# controls DQas and DQP _a ; BWb# controls DQbs and DQP _b . For the x32 and x36 versions, BWa# controls DQas and DQP _a ; BWb# controls DQbs and DQP _b ; BWc# controls DQc's and DQP _c ; BWD# controls DQds and DQP _d . Parity is only available on the x18 and x36 versions.
7A	7A	BWE#	Input	Byte Write Enable: This active LOW input permits BYTE WRITE operations and must meet the setup and hold times around the rising edge of CLK.
7B	7B	GW#	Input	Global Write: This active LOW input allows a full 18-, 32- or 36-bit WRITE to occur independent of the BWE# and BWx# lines and must meet the setup and hold times around the rising edge of CLK.
6B	6B	CLK	Input	Clock: This signal registers the address, data, chip enable, byte write enables, and burst control inputs on its rising edge. All synchronous inputs must meet setup and hold times around the clock's rising edge.
3A	3A	CE#	Input	Synchronous Chip Enable: This active LOW input is used to enable the device and conditions the internal use of ADSP#. CE# is sampled only when a new external address is loaded.
6A	6A	CE2#	Input	Synchronous Chip Enable: This active LOW input is used to enable the device and is sampled only when a new external address is loaded.
11H	11H	ZZ	Input	Snooze Enable: This active HIGH, asynchronous input causes the device to enter a low-power standby mode in which all data in the memory array is retained. When ZZ is active, all other inputs are ignored.
3B	3B	CE2	Input	Synchronous Chip Enable: This active HIGH input is used to enable the device and is sampled only when a new external address is loaded.
8B	8B	OE#(G#)	Input	Output Enable: This active LOW, asynchronous input enables the data I/O output drivers.

(continued on next page)

FBGA PIN DESCRIPTIONS (continued)

x18	x32/x36	SYMBOL	TYPE	DESCRIPTION
9A	9A	ADV#	Input	Synchronous Address Advance: This active LOW input is used to advance the internal burst counter, controlling burst access after the external address is loaded. A HIGH on ADV# effectively causes wait states to be generated (no address advance). To ensure use of correct address during a WRITE cycle, ADV# must be HIGH at the rising edge of the first clock after an ADSP# cycle is initiated.
9B	9B	ADSP#	Input	Synchronous Address Status Processor: This active LOW input interrupts any ongoing burst, causing a new external address to be registered. A READ is performed using the new address, independent of the byte write enables and ADSC#, but dependent upon CE#, CE2, and CE2#. ADSP# is ignored if CE# is HIGH. Power-down state is entered if CE2 is LOW or CE2# is HIGH.
8A	8A	ADSC#	Input	Synchronous Address Status Controller: This active LOW input interrupts any ongoing burst, causing a new external address to be registered. A READ or WRITE is performed using the new address if CE# is LOW. ADSC# is also used to place the chip into power-down state when CE# is HIGH.
1R	1R	MODE (LB0#)	Input	Mode: This input selects the burst sequence. A LOW on this input selects "linear burst." NC or HIGH on this input selects "interleaved burst." Do not alter input state while device is operating.
(a) 10J, 10K, 10L, 10M, 11D, 11E, 11F, 11G (b) 1J, 1K, 1L, 1M, 2D, 2E, 2F, 2G	(a) 10J, 10K, 10L, 10M, 11J, 11K, 11L, 11M (b) 10D, 10E, 10F, 10G, 11D, 11E, 11F, 11G (c) 1D, 1E, 1F, 1G, 2D, 2E, 2F, 2G (d) 1J, 1K, 1L, 1M, 2J, 2K, 2L, 2M	DQa DQb DQc DQd	Input/ Output	SRAM Data I/Os: For the x18 version, Byte "a" is associated DQas; Byte "b" is associated with DQbs. For the x32 and x36 versions, Byte "a" is associated with DQas; Byte "b" is associated with DQbs; Byte "c" is associated with DQcs; Byte "d" is associated with DQds. Input data must meet setup and hold times around the rising edge of CLK.
11C 1N – –	11N 11C 1C 1N	NF/DQPa NF/DQPb NF/DQPc NF/DQPd	NF/ I/O	No Function/Parity Data I/Os: On the x32 version, these are No Function (NF). On the x18 version, Byte "a" parity is DQPa; Byte "b" parity is DQPb. On the x36 version, Byte "a" parity is DQPa; Byte "b" parity is DQPb; Byte "c" parity is DQPc; Byte "d" parity is DQPd.
4D, 4E, 4F, 4G, 4H, 4J, 4K, 4L, 4M, 8D, 8E, 8F, 8G, 8H, 8J, 8K, 8L, 8M	4D, 4E, 4F, 4G, 4H, 4J, 4K, 4L, 4M, 8D, 8E, 8F, 8G, 8H, 8J, 8K, 8L, 8M	VDD	Supply	Power Supply: See DC Electrical Characteristics and Operating Conditions for range.

(continued on next page)

FBGA PIN DESCRIPTIONS (continued)

x18	x32/x36	SYMBOL	TYPE	DESCRIPTION
3C, 3D, 3E, 3F, 3G, 3J, 3K, 3L, 3M, 3N, 9C, 9D, 9E, 9F, 9G, 9J, 9K, 9L, 9M, 9N	3C, 3D, 3E, 3F, 3G, 3J, 3K, 3L, 3M, 3N, 9C, 9D, 9E, 9F, 9G, 9J, 9K, 9L, 9M, 9N	V _{DDQ}	Supply	Isolated Output Buffer Supply: See DC Electrical Characteristics and Operating Conditions for range.
1H, 2H, 4C, 4N, 5C, 5D, 5E 5F, 5G, 5H, 5J, 5K, 5L, 5M, 6C, 6D, 6E, 6F, 6G, 6H, 6J, 6K, 6L, 6M, 7C, 7D, 7E, 7F, 7G, 7H, 7J, 7K, 7L, 7M, 7N, 8C, 8N	1H, 2H, 4C, 4N, 5C, 5D, 5E 5F, 5G, 5H, 5J, 5K, 5L, 5M, 6C, 6D, 6E, 6F, 6G, 6H, 6J, 6K, 6L, 6M, 7C, 7D, 7E, 7F, 7G, 7H, 7J, 7K, 7J, 7M, 7N, 8C, 8N	V _{SS}	Supply	Ground: GND.
5P, 5R, 7P, 7R	5P, 5R, 7P, 7R	DNU	—	Do Not Use: These signals may either be unconnected or wired to GND to improve package heat dissipation.
1A, 1B, 1C, 1D, 1E, 1F, 1G, 1P, 2C, 2J, 2K, 2L, 2M, 2N, 2P, 2R, 3H, 4B, 5A, 5N, 6N, 9H, 10C, 10D, 10E, 10F, 10G, 10H, 10N, 11B, 11J, 11K, 11L, 11M, 11N	1A, 1B, 1P, 2C, 2N, 2P, 2R, 3H, 5N, 6N, 9H, 10C, 10H, 10N, 11A, 11B,	NC	—	No Connect: These signals are not internally connected and may be connected to ground to improve package heat dissipation. Pin 6N reserved for address pin expansion; 18Mb.
		NF	—	No Function: These pins are internally connected to the die and have the capacitance of an input pin. It is allowable to leave these pins unconnected or driven by signals.

INTERLEAVED BURST ADDRESS TABLE (MODE = NC OR HIGH)

FIRST ADDRESS (EXTERNAL)	SECOND ADDRESS (INTERNAL)	THIRD ADDRESS (INTERNAL)	FOURTH ADDRESS (INTERNAL)
X...X00	X...X01	X...X10	X...X11
X...X01	X...X00	X...X11	X...X10
X...X10	X...X11	X...X00	X...X01
X...X11	X...X10	X...X01	X...X00

LINEAR BURST ADDRESS TABLE (MODE = LOW)

FIRST ADDRESS (EXTERNAL)	SECOND ADDRESS (INTERNAL)	THIRD ADDRESS (INTERNAL)	FOURTH ADDRESS (INTERNAL)
X...X00	X...X01	X...X10	X...X11
X...X01	X...X10	X...X11	X...X00
X...X10	X...X11	X...X00	X...X01
X...X11	X...X00	X...X01	X...X10

PARTIAL TRUTH TABLE FOR WRITE COMMANDS (x18)

FUNCTION	GW#	BWE#	BWa#	BWb#
READ	H	H	X	X
READ	H	L	H	H
WRITE Byte "a"	H	L	L	H
WRITE Byte "b"	H	L	H	L
WRITE All Bytes	H	L	L	L
WRITE All Bytes	L	X	X	X

PARTIAL TRUTH TABLE FOR WRITE COMMANDS (x32/x36)

FUNCTION	GW#	BWE#	BWa#	BWb#	BWc#	BWd#
READ	H	H	X	X	X	X
READ	H	L	H	H	H	H
WRITE Byte "a"	H	L	L	H	H	H
WRITE All Bytes	H	L	L	L	L	L
WRITE All Bytes	L	X	X	X	X	X

NOTE: Using BWE# and BWa# through BWd#, any one or more bytes may be written.



TRUTH TABLE

OPERATION	ADDRESS USED	CE#	CE2#	CE2	ZZ	ADSP#	ADSC#	ADV#	WRITE#	OE#	CLK	DQ
Deselected Cycle, Power-Down	None	H	X	X	L	X	L	X	X	X	L-H	High-Z
Deselected Cycle, Power-Down	None	L	X	L	L	L	X	X	X	X	L-H	High-Z
Deselected Cycle, Power-Down	None	L	H	X	L	L	X	X	X	X	L-H	High-Z
Deselected Cycle, Power-Down	None	L	X	L	L	H	L	X	X	X	L-H	High-Z
Deselected Cycle, Power-Down	None	L	H	X	L	H	L	X	X	X	L-H	High-Z
SNOOZE MODE, Power-Down	None	X	X	X	H	X	X	X	X	X	X	High-Z
READ Cycle, Begin Burst	External	L	L	H	L	L	X	X	X	L	L-H	Q
READ Cycle, Begin Burst	External	L	L	H	L	L	X	X	X	H	L-H	High-Z
WRITE Cycle, Begin Burst	External	L	L	H	L	H	L	X	L	X	L-H	D
READ Cycle, Begin Burst	External	L	L	H	L	H	L	X	H	L	L-H	Q
READ Cycle, Begin Burst	External	L	L	H	L	H	L	X	H	H	L-H	High-Z
READ Cycle, Continue Burst	Next	X	X	X	L	H	H	L	H	L	L-H	Q
READ Cycle, Continue Burst	Next	X	X	X	L	H	H	L	H	H	L-H	High-Z
READ Cycle, Continue Burst	Next	H	X	X	L	X	H	L	H	L	L-H	Q
READ Cycle, Continue Burst	Next	H	X	X	L	X	H	L	H	H	L-H	High-Z
WRITE Cycle, Continue Burst	Next	X	X	X	L	H	H	L	L	X	L-H	D
WRITE Cycle, Continue Burst	Next	H	X	X	L	X	H	L	L	X	L-H	D
READ Cycle, Suspend Burst	Current	X	X	X	L	H	H	H	H	L	L-H	Q
READ Cycle, Suspend Burst	Current	X	X	X	L	H	H	H	H	H	L-H	High-Z
READ Cycle, Suspend Burst	Current	H	X	X	L	X	H	H	H	L	L-H	Q
READ Cycle, Suspend Burst	Current	H	X	X	L	X	H	H	H	H	L-H	High-Z
WRITE Cycle, Suspend Burst	Current	X	X	X	L	H	H	H	L	X	L-H	D
WRITE Cycle, Suspend Burst	Current	H	X	X	L	X	H	H	L	X	L-H	D

- NOTE:
1. X means "Don't Care." # means active LOW. H means logic HIGH. L means logic LOW.
 2. For WRITE#, L means any one or more byte write enable signals (BWA#, BWb#, BWc# or BWD#) and BWE# are LOW or GW# is LOW. WRITE# = H for all BWx#, BWE#, GW# HIGH.
 3. BWA# enables WRITES to DQa pins, DQPa. BWb# enables WRITES to DQb and DQPb. BWc# enables WRITES to DQc and DQPc. BWD# enables WRITES to DQd and DQPd. DQPa and DQPb are only available on the x18 and x36 versions. DQPc and DQPd are only available on the x36 version.
 4. All inputs except OE# and ZZ must meet setup and hold times around the rising edge (LOW to HIGH) of CLK.
 5. Wait states are inserted by suspending burst.
 6. For a WRITE operation following a READ operation, OE# must be HIGH before the input data setup time and held HIGH throughout the input data hold time.
 7. This device contains circuitry that will ensure the outputs will be in High-Z during power-up.
 8. ADSP# LOW always initiates an internal READ at the L-H edge of CLK. A WRITE is performed by setting one or more byte write enable signals and BWE# LOW or GW# LOW for the subsequent L-H edge of CLK. Refer to WRITE timing diagram for clarification.



ABSOLUTE MAXIMUM RATINGS*

Voltage on V _{DD} Supply	
Relative to V _{SS}	-0.5V to +4.6V
Voltage on V _{DDQ} Supply	
Relative to V _{SS}	-0.5V to +4.6V
V _{IN} (DQx)	-0.5V to V _{DDQ} + 0.5V
V _{IN} (inputs)	-0.5V to V _{DD} + 0.5V
Storage Temperature (plastic)	-55°C to +150°C
Storage Temperature (FBGA)	-55°C to +125°C
Junction Temperature**	+150°C
Short Circuit Output Current	100mA

*Stresses greater than those listed under “Absolute Maximum Ratings” may cause permanent damage to the device. This is a stress rating only, and functional operation of the device at these or any other conditions above those indicated in the operational sections of this specification is not implied. Exposure to absolute maximum rating conditions for extended periods may affect reliability.

**Maximum junction temperature depends upon package type, cycle time, loading, ambient temperature and airflow. See Micron Technical Note TN-05-14 for more information.

3.3V I/O DC ELECTRICAL CHARACTERISTICS AND OPERATING CONDITIONS

(0°C ≤ T_A ≤ +70°C; V_{DD}, V_{DDQ} = +3.3V +0.3V/-0.165V unless otherwise noted)

DESCRIPTION	CONDITIONS	SYMBOL	MIN	MAX	UNITS	NOTES
Input High (Logic 1) Voltage		V _{IH}	2.0	V _{DD} + 0.3	V	1, 2
Input Low (Logic 0) Voltage		V _{IL}	-0.3	0.8	V	1, 2
Input Leakage Current	0V ≤ V _{IN} ≤ V _{DD}	I _{LI}	-1.0	1.0	μA	3
Output Leakage Current	Output(s) disabled, 0V ≤ V _{IN} ≤ V _{DD}	I _{LO}	-1.0	1.0	μA	
Output High Voltage	I _{OH} = -4.0mA	V _{OH}	2.4	-	V	1, 4
Output Low Voltage	I _{OL} = 8.0mA	V _{OL}	-	0.4	V	1, 4
Supply Voltage		V _{DD}	3.135	3.6	V	1
Isolated Output Buffer Supply		V _{DDQ}	3.135	3.6	V	1, 5

- NOTE:**
- All voltages referenced to V_{SS} (GND).
 - Overshoot: V_{IH} ≤ +4.6V for t ≤ ^tKC/2 for I ≤ 20mA
Undershoot: V_{IL} ≥ -0.7V for t ≤ ^tKC/2 for I ≤ 20mA
Power-up: V_{IH} ≤ +3.6V and V_{DD} ≤ 3.135V for t ≤ 200ms
 - MODE has an internal pull-up, and input leakage = ±10μA.
 - The load used for V_{OH}, V_{OL} testing is shown in Figure 2 for 3.3V I/O. AC load current is higher than the stated DC values. AC I/O curves are available upon request.
 - V_{DDQ} should never exceed V_{DD}. V_{DD} and V_{DDQ} can be connected together.

2.5V I/O DC ELECTRICAL CHARACTERISTICS AND OPERATING CONDITIONS

($0^{\circ}\text{C} \leq T_A \leq +70^{\circ}\text{C}$; $V_{DD} = +3.3\text{V} +0.3\text{V}/-0.165\text{V}$; $V_{DDQ} = +2.5\text{V} +0.4\text{V}/-0.125\text{V}$ unless otherwise noted)

DESCRIPTION	CONDITIONS	SYMBOL	MIN	MAX	UNITS	NOTES
Input High (Logic 1) Voltage	Data bus (DQx)	V_{IHQ}	1.7	$V_{DDQ} + 0.3$	V	1, 2
	Inputs	V_{IH}	1.7	$V_{DD} + 0.3$	V	1, 2
Input Low (Logic 0) Voltage		V_{IL}	-0.3	0.7	V	1, 2
Input Leakage Current	$0\text{V} \leq V_{IN} \leq V_{DD}$	I_{LI}	-1.0	1.0	μA	3
Output Leakage Current	Output(s) disabled, $0\text{V} \leq V_{IN} \leq V_{DDQ}$ (DQx)	I_{Lo}	-1.0	1.0	μA	
Output High Voltage	$I_{OH} = -2.0\text{mA}$	V_{OH}	1.7	-	V	1, 4
	$I_{OH} = -1.0\text{mA}$	V_{OH}	2.0	-	V	1, 4
Output Low Voltage	$I_{OL} = 2.0\text{mA}$	V_{OL}	-	0.7	V	1, 4
	$I_{OL} = 1.0\text{mA}$	V_{OL}	-	0.4	V	1, 4
Supply Voltage		V_{DD}	3.135	3.6	V	1
Isolated Output Buffer Supply		V_{DDQ}	2.375	2.9	V	1

- NOTE:**
- All voltages referenced to V_{SS} (GND).
 - Overshoot: $V_{IH} \leq +4.6\text{V}$ for $t \leq t_{KC}/2$ for $I \leq 20\text{mA}$
Undershoot: $V_{IL} \geq -0.7\text{V}$ for $t \leq t_{KC}/2$ for $I \leq 20\text{mA}$
Power-up: $V_{IH} \leq +3.6\text{V}$ and $V_{DD} \leq 3.135\text{V}$ for $t \leq 200\text{ms}$
 - MODE has an internal pull-up, and input leakage = $\pm 10\mu\text{A}$.
 - The load used for V_{OH} , V_{OL} testing is shown in Figure 4 for 2.5V I/O. AC load current is higher than the stated DC values. AC I/O curves are available upon request.
 - This parameter is sampled.

I_{DD} OPERATING CONDITIONS AND MAXIMUM LIMITS

 (Note 1) (0°C ≤ T_A ≤ +70°C; V_{DD} = +3.3V +0.3V/-0.165V unless otherwise noted)

DESCRIPTION	CONDITIONS	SYMBOL	TYP	MAX			UNITS	NOTES
				-7.5	-8.5	-10		
Power Supply Current: Operating	Device selected; All inputs ≤ V _{IL} or ≥ V _{IH} ; Cycle time ≥ ^t KC (MIN); V _{DD} = MAX; Outputs open	I _{DD}	155	375	325	250	mA	2, 3, 4
Power Supply Current: Idle	Device selected; V _{DD} = MAX; ADSC#, ADSP#, ADV#, GW#, BWx# ≥ V _{IH} ; All inputs ≤ V _{SS} + 0.2 or ≥ V _{DD} - 0.2; Cycle time ≥ ^t KC (MIN); Outputs open	I _{DD1}	35	100	85	65	mA	2, 3, 4
CMOS Standby	Device deselected; V _{DD} = MAX; All inputs ≤ V _{SS} + 0.2 or ≥ V _{DD} - 0.2; All inputs static; CLK frequency = 0	I _{SB2}	0.4	10	10	10	mA	3, 4
TTL Standby	Device deselected; V _{DD} = MAX; All inputs ≤ V _{IL} or ≥ V _{IH} ; All inputs static; CLK frequency = 0	I _{SB3}	8	25	25	25	mA	3, 4
Clock Running	Device deselected; V _{DD} = MAX; ADSC#, ADSP#, ADV#, GW#, BWx# ≥ V _{IH} ; All inputs ≤ V _{SS} + 0.2 or ≥ V _{DD} - 0.2; Cycle time ≥ ^t KC (MIN)	I _{SB4}	35	100	85	65	mA	3, 4

TQFP CAPACITANCE

DESCRIPTION	CONDITIONS	SYMBOL	TYP	MAX	UNITS	NOTES
Control Input Capacitance	T _A = 25°C; f = 1 MHz; V _{DD} = 3.3V	C _I	3	4	pF	5
Input/Output Capacitance (DQ)		C _O	4	5	pF	5
Address Capacitance		C _A	3	3.5	pF	5
Clock Capacitance		C _{CK}	3	3.5	pF	5

- NOTE:**
1. V_{DDQ} = +3.3V +0.3V/-0.165V for 3.3V I/O configuration; V_{DDQ} = +2.5V +0.4V/-0.125V for 2.5V I/O configuration.
 2. I_{DD} is specified with no output current and increases with faster cycle times. I_{DDQ} increases with faster cycle times and greater output loading.
 3. "Device deselected" means device is in power-down mode as defined in the truth table. "Device selected" means device is active (not in power-down mode).
 4. Typical values are measured at 3.3V, 25°C, and 15ns cycle time.
 5. This parameter is sampled.

FBGA CAPACITANCE

DESCRIPTION	CONDITIONS	SYMBOL	TYP	MAX	UNITS	NOTES
Address/Control Input Capacitance	$T_A = 25^\circ\text{C}; f = 1 \text{ MHz}$	C_i	2.5	3.5	pF	1
Output Capacitance (Q)		C_o	4	5	pF	1
Clock Capacitance		C_{ck}	2.5	3.5	pF	1

TQFP THERMAL RESISTANCE

DESCRIPTION	CONDITIONS	SYMBOL	TYP	UNITS	NOTES	
Thermal Resistance (Junction to Ambient)	Test conditions follow standard test methods and procedures for measuring thermal impedance, per EIA/JESD51.	1-layer	θ_{JA}	40	$^\circ\text{C/W}$	1
Thermal Resistance (Junction to Top of Case)			θ_{JC}	8	$^\circ\text{C/W}$	1

FBGA THERMAL RESISTANCE

DESCRIPTION	CONDITIONS	SYMBOL	TYP	UNITS	NOTES
Junction to Ambient (Airflow of 1m/s)	Test conditions follow standard test methods and procedures for measuring thermal impedance, per EIA/JESD51.	θ_{JA}	40	$^\circ\text{C/W}$	1
Junction to Case (Top)		θ_{JC}	9	$^\circ\text{C/W}$	1
Junction to Pins (Bottom)		θ_{JB}	17	$^\circ\text{C/W}$	1

- NOTE:**
1. This parameter is sampled.
 2. Preliminary package data.

ELECTRICAL CHARACTERISTICS AND RECOMMENDED AC OPERATING CONDITIONS

 (Note 1) ($0^{\circ}\text{C} \leq T_A \leq 70^{\circ}\text{C}$; $V_{DD} = +3.3\text{V} +0.3\text{V}/-0.165\text{V}$ unless otherwise noted)

DESCRIPTION	SYMBOL	-7.5		-8.5		-10		UNITS	NOTES
		MIN	MAX	MIN	MAX	MIN	MAX		
Clock									
Clock cycle time	t_{KC}	8.8		10.0		15		ns	
Clock frequency	f_{KF}		113		100		66	MHz	
Clock HIGH time	t_{KH}	2.5		3.0		4.0		ns	2
Clock LOW time	t_{KL}	2.5		3.0		4.0		ns	2
Output Times									
Clock to output valid	t_{KQ}		7.5		8.5		10.0	ns	
Clock to output invalid	t_{KQX}	1.5		3.0		3.0		ns	3
Clock to output in Low-Z	t_{KQLZ}	1.5		3.0		3.0		ns	3, 4, 5, 6
Clock to output in High-Z	t_{KQHZ}		4.2		5.0		5.0	ns	3, 4, 5, 6
OE# to output valid	t_{OEQ}		4.2		5.0		5.0	ns	7
OE# to output in Low-Z	t_{OELZ}	0		0		0		ns	3, 4, 5, 6
OE# to output in High-Z	t_{OEHZ}		4.2		5.0		5.0	ns	3, 4, 5, 6
Setup Times									
Address	t_{AS}	1.5		1.8		2.0		ns	8, 9
Address status (ADSC#, ADSP#)	t_{ADSS}	1.5		1.8		2.0		ns	8, 9
Address advance (ADV#)	t_{AAS}	1.5		1.8		2.0		ns	8, 9
Byte write enables (BWA#-BWd#, GW#, BWE#)	t_{WS}	1.5		1.8		2.0		ns	8, 9
Data-in	t_{DS}	1.5		1.8		2.0		ns	8, 9
Chip enable (CE#)	t_{CES}	1.5		1.8		2.0		ns	8, 9
Hold Times									
Address	t_{AH}	0.5		0.5		0.5		ns	8, 9
Address status (ADSC#, ADSP#)	t_{ADSH}	0.5		0.5		0.5		ns	8, 9
Address advance (ADV#)	t_{AAH}	0.5		0.5		0.5		ns	8, 9
Byte write enables (BWA#-BWd#, GW#, BWE#)	t_{WH}	0.5		0.5		0.5		ns	8, 9
Data-in	t_{DH}	0.5		0.5		0.5		ns	8, 9
Chip enable (CE#)	t_{CEH}	0.5		0.5		0.5		ns	8, 9

- NOTE:**
1. Test conditions as specified with the output loading shown in Figure 1 for 3.3V I/O ($V_{DDQ} = +3.3\text{V} +0.3\text{V}/-0.165\text{V}$) and Figure 3 for 2.5V I/O ($V_{DDQ} = +2.5\text{V} +0.4\text{V}/-0.125\text{V}$ for 2.5V I/O) unless otherwise noted.
 2. Measured as HIGH above V_{IH} and LOW below V_{IL} .
 3. This parameter is measured with the output loading shown in Figure 2 for 3.3V I/O and Figure 4 for 2.5V I/O.
 4. This parameter is sampled.
 5. Transition is measured $\pm 500\text{mV}$ from steady state voltage.
 6. Refer to Technical Note TN-58-09, "Synchronous SRAM Bus Contention Design Considerations," for a more thorough discussion on these parameters.
 7. OE# is a "Don't Care" when a byte write enable is sampled LOW.
 8. A READ cycle is defined by byte write enables all HIGH or ADSP# LOW for the required setup and hold times. A WRITE cycle is defined by at least one byte write enable LOW and ADSP# HIGH for the required setup and hold times.
 9. This is a synchronous device. All addresses must meet the specified setup and hold times for all rising edges of CLK when either ADSP# or ADSC# is LOW and chip enabled. All other synchronous inputs must meet the setup and hold times with stable logic levels for all rising edges of clock (CLK) when the chip is enabled. Chip enable must be valid at each rising edge of CLK when either ADSP# or ADSC# is LOW to remain enabled.

3.3V I/O AC TEST CONDITIONS

Input pulse levels	$V_{IH} = (V_{DD}/2.2) + 1.5V$
.....	$V_{IL} = (V_{DD}/2.2) - 1.5V$
Input rise and fall times	1ns
Input timing reference levels	$V_{DD}/2.2$
Output reference levels	$V_{DDQ}/2.2$
Output load	See Figures 1 and 2

2.5V I/O AC TEST CONDITIONS

Input pulse levels	$V_{IH} = (V_{DD}/2.64) + 1.25V$
.....	$V_{IL} = (V_{DD}/2.64) - 1.25V$
Input rise and fall times	1ns
Input timing reference levels	$V_{DD}/2.64$
Output reference levels	$V_{DDQ}/2$
Output load	See Figures 3 and 4

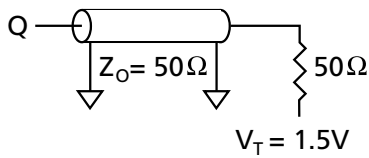

Figure 1
3.3V I/O OUTPUT LOAD EQUIVALENT

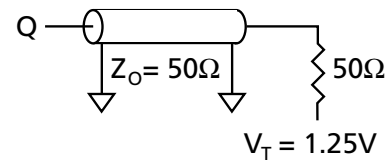

Figure 3
2.5V I/O OUTPUT LOAD EQUIVALENT

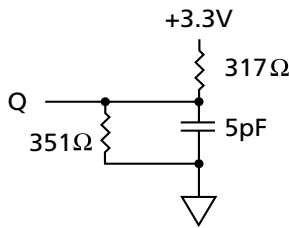

Figure 2
3.3V I/O OUTPUT LOAD EQUIVALENT

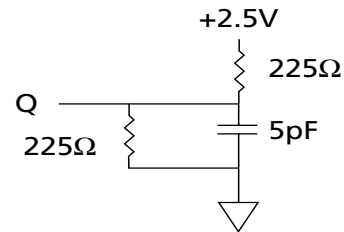

Figure 4
2.5V I/O OUTPUT LOAD EQUIVALENT

LOAD DERATING CURVES

Micron 512K x 18, 256K x 32, and 256K x 36 SyncBurst SRAM timing is dependent upon the capacitive loading on the outputs.

Consult the factory for copies of I/O current versus voltage curves.

SNOOZE MODE

SNOOZE MODE is a low-current, “power-down” mode in which the device is deselected and current is reduced to I_{SB2Z} . The duration of SNOOZE MODE is dictated by the length of time ZZ is in a HIGH state. After the device enters SNOOZE MODE, all inputs except ZZ become gated inputs and are ignored.

ZZ is an asynchronous, active HIGH input that causes the device to enter SNOOZE MODE. When ZZ becomes a logic HIGH, I_{SB2Z} is guaranteed after the setup time t_{ZZ} is met. Any READ or WRITE operation pending when the device enters SNOOZE MODE is not guaranteed to complete successfully. Therefore, SNOOZE MODE must not be initiated until valid pending operations are completed.

SNOOZE MODE ELECTRICAL CHARACTERISTICS

DESCRIPTION	CONDITIONS	SYMBOL	MIN	MAX	UNITS	NOTES
Current during SNOOZE MODE	$ZZ \geq V_{IH}$	I_{SB2Z}		10	mA	
ZZ active to input ignored		t_{ZZ}		t_{KC}	ns	1
ZZ inactive to input sampled		t_{RZZ}	t_{KC}		ns	1
ZZ active to snooze current		t_{ZZI}		t_{KC}	ns	1
ZZ inactive to exit snooze current		t_{RZZI}	0		ns	1

NOTE: 1. This parameter is sampled.

SNOOZE MODE WAVEFORM

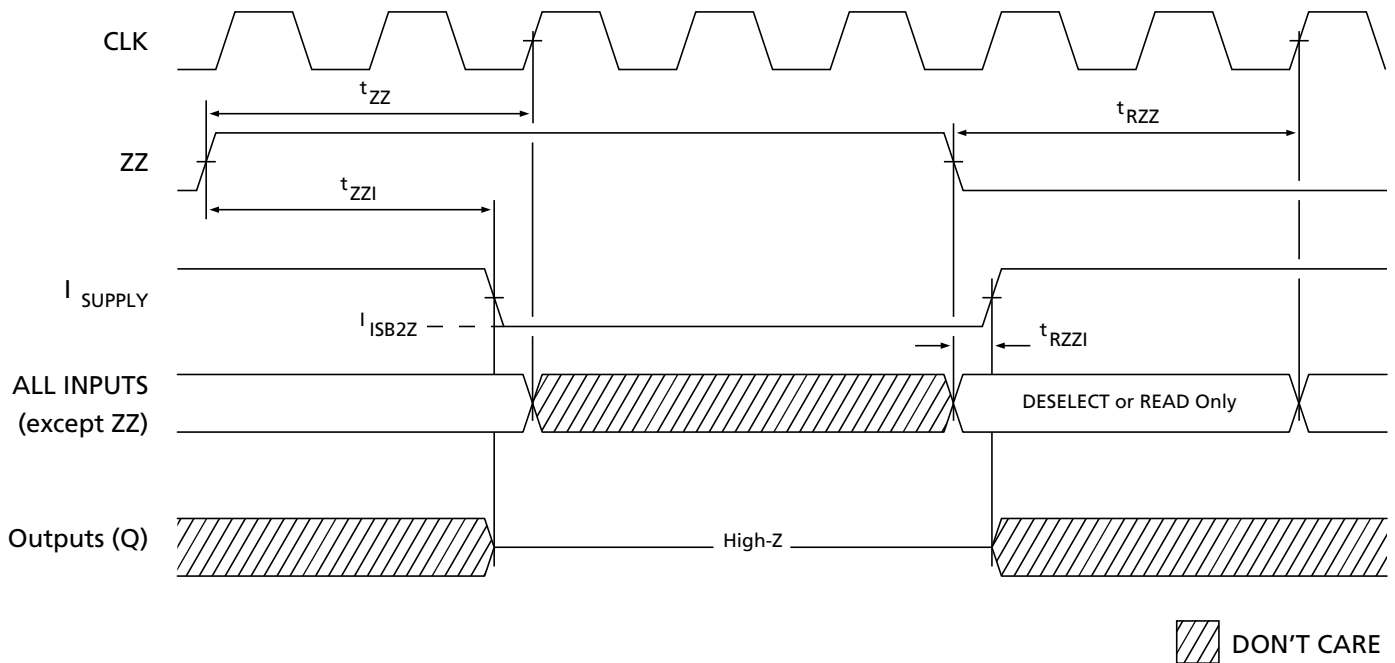

READ TIMING ³

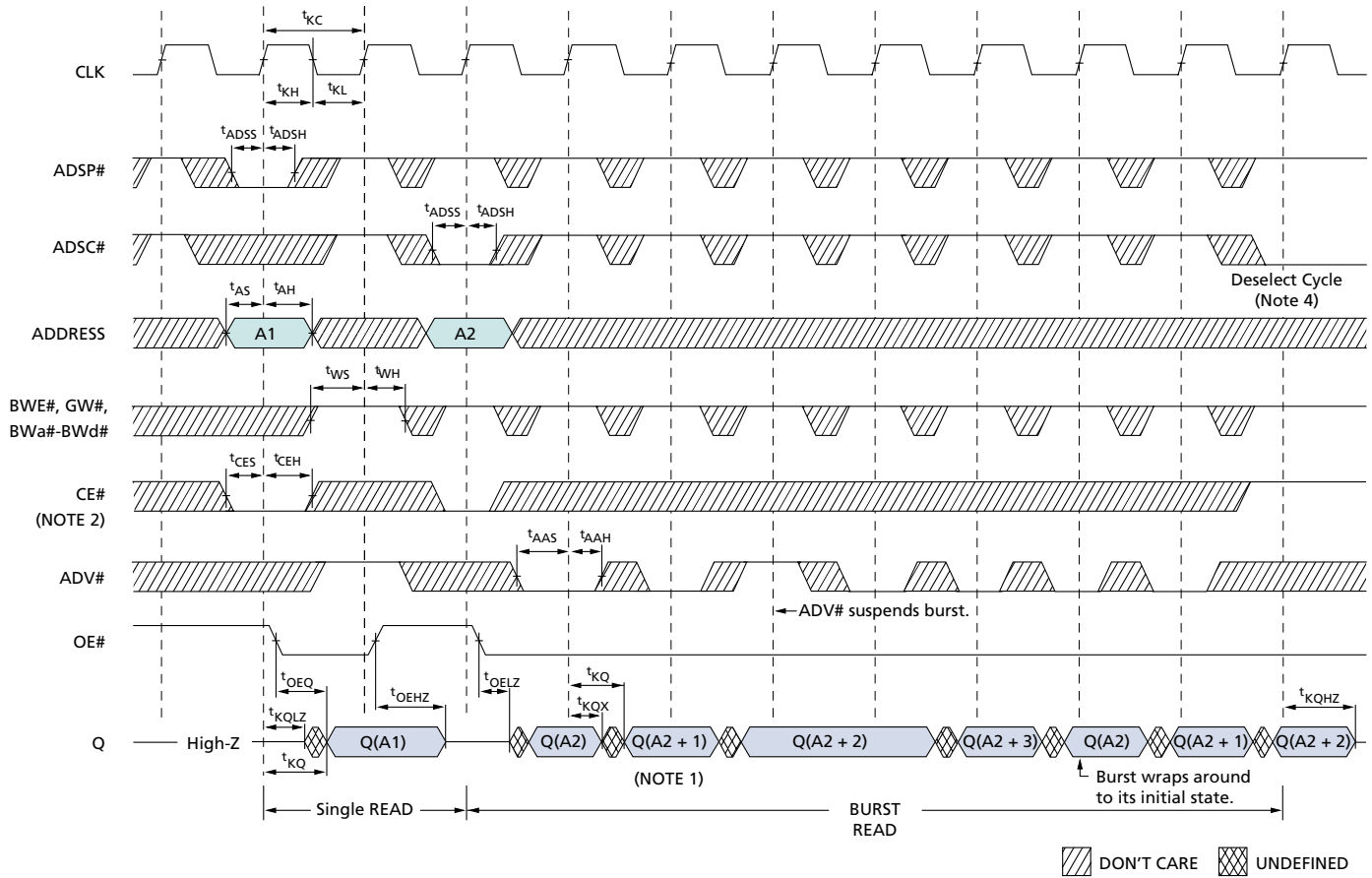

READ/WRITE TIMING PARAMETERS

SYM	-7.5		-8.5		-10		UNITS
	MIN	MAX	MIN	MAX	MIN	MAX	
t_{KC}	8.8		10.0		15		ns
f_{KF}		113		100		66	MHz
t_{KH}	2.5		3.0		4.0		ns
t_{KL}	2.5		3.0		4.0		ns
t_{KQ}		7.5		8.5		10.0	ns
t_{KQX}	1.5		3.0		3.0		ns
t_{KQLZ}	1.5		3.0		3.0		ns
t_{KQHZ}		4.2		5.0		5.0	ns
t_{OEQ}		4.2		5.0		5.0	ns
t_{OELZ}	0		0		0		ns
t_{OEZH}		4.2		5.0		5.0	ns

SYM	-7.5		-8.5		-10		UNITS
	MIN	MAX	MIN	MAX	MIN	MAX	
t_{AS}	1.5		1.8		2.0		ns
t_{ADSS}	1.5		1.8		2.0		ns
t_{AAS}	1.5		1.8		2.0		ns
t_{WS}	1.5		1.8		2.0		ns
t_{CES}	1.5		1.8		2.0		ns
t_{AH}	0.5		0.5		0.5		ns
t_{ADSH}	0.5		0.5		0.5		ns
t_{AAH}	0.5		0.5		0.5		ns
t_{WH}	0.5		0.5		0.5		ns
t_{CEH}	0.5		0.5		0.5		ns

- NOTE:**
- Q(A2) refers to output from address A2. Q(A2 + 1) refers to output from the next internal burst address following A2.
 - CE2# and CE2 have timing identical to CE#. On this diagram, when CE# is LOW, CE2# is LOW and CE2 is HIGH. When CE# is HIGH, CE2# is HIGH and CE2 is LOW.
 - Timing is shown assuming that the device was not enabled before entering into this sequence.
 - Outputs are disabled t_{KQHZ} after deselect.

WRITE TIMING

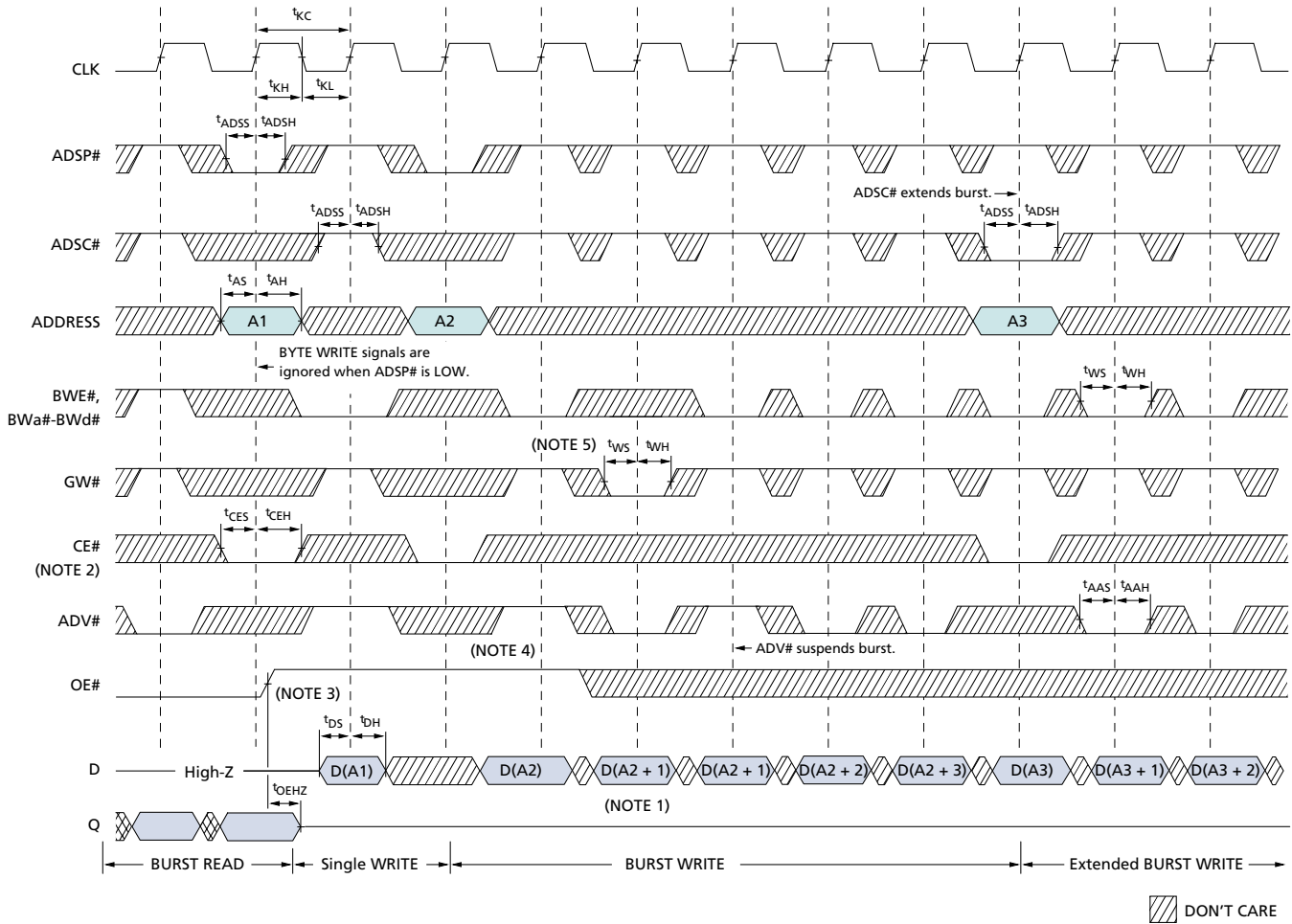

WRITE TIMING PARAMETERS

SYM	-7.5		-8.5		-10		UNITS
	MIN	MAX	MIN	MAX	MIN	MAX	
t_{KC}	8.8		10.0		15		ns
f_{KF}		113		100		66	MHz
t_{KH}	2.5		3.0		4.0		ns
t_{KL}	2.5		3.0		4.0		ns
t_{OEZH}		4.2		5.0		5.0	ns
t_{AS}	1.5		1.8		2.0		ns
t_{ADSS}	1.5		1.8		2.0		ns
t_{AAS}	1.5		1.8		2.0		ns
t_{WS}	1.5		1.8		2.0		ns

SYM	-7.5		-8.5		-10		UNITS
	MIN	MAX	MIN	MAX	MIN	MAX	
t_{DS}	1.5		1.8		2.0		ns
t_{CES}	1.5		1.8		2.0		ns
t_{AH}	0.5		0.5		0.5		ns
t_{ADSH}	0.5		0.5		0.5		ns
t_{AAH}	0.5		0.5		0.5		ns
t_{WH}	0.5		0.5		0.5		ns
t_{DH}	0.5		0.5		0.5		ns
t_{CEH}	0.5		0.5		0.5		ns

- NOTE:**
- D(A2) refers to output from address A2. D(A2 + 1) refers to output from the next internal burst address following A2.
 - CE2# and CE2 have timing identical to CE#. On this diagram, when CE# is LOW, CE2# is LOW and CE2 is HIGH. When CE# is HIGH, CE2# is HIGH and CE2 is LOW.
 - OE# must be HIGH before the input data setup and held HIGH throughout the data hold time. This prevents input/output data contention for the time period prior to the byte write enable inputs being sampled.
 - ADV# must be HIGH to permit a WRITE to the loaded address.
 - Full-width WRITE can be initiated by GW# LOW; or GW# HIGH and BWE#, BWA# and BWb# LOW for x18 device; or GW# HIGH and BWE#, BWA#-BWD# LOW for x32 and x36 devices.

READ/WRITE TIMING ³

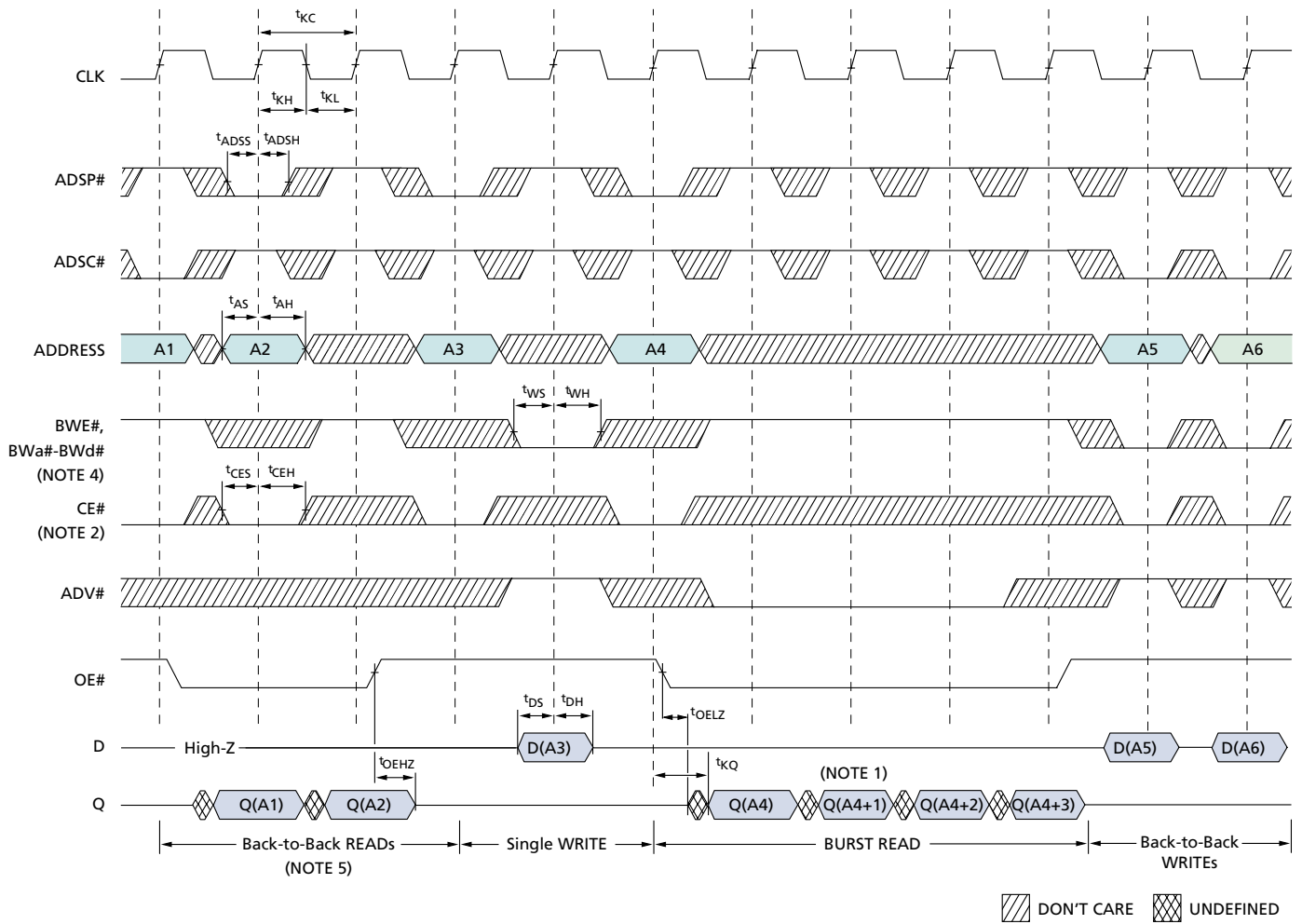

READ/WRITE TIMING PARAMETERS

SYM	-7.5		-8.5		-10		UNITS
	MIN	MAX	MIN	MAX	MIN	MAX	
t _{KC}	8.8		10.0		15		ns
f _{KF}		113		100		66	MHz
t _{KH}	2.5		3.0		4.0		ns
t _{KL}	2.5		3.0		4.0		ns
t _{KQ}		7.5		8.5		10.0	ns
t _{OELZ}	0		0		0		ns
t _{OEHZ}		4.2		5.0		5.0	ns
t _{AS}	1.5		1.8		2.0		ns
t _{ADSS}	1.5		1.8		2.0		ns

SYM	-7.5		-8.5		-10		UNITS
	MIN	MAX	MIN	MAX	MIN	MAX	
t _{WS}	1.5		1.8		2.0		ns
t _{DS}	1.5		1.8		2.0		ns
t _{CES}	1.5		1.8		2.0		ns
t _{AH}	0.5		0.5		0.5		ns
t _{ADSH}	0.5		0.5		0.5		ns
t _{WH}	0.5		0.5		0.5		ns
t _{DH}	0.5		0.5		0.5		ns
t _{CEH}	0.5		0.5		0.5		ns

- NOTE:**
- Q(A4) refers to output from address A4. Q(A4 + 1) refers to output from the next internal burst address following A4.
 - CE2# and CE2 have timing identical to CE#. On this diagram, when CE# is LOW, CE2# is LOW and CE2 is HIGH. When CE# is HIGH, CE2# is HIGH and CE2 is LOW.
 - The data bus (Q) remains in High-Z following a WRITE cycle unless an ADSP#, ADSC# or ADV# cycle is performed.
 - GW# is HIGH.
 - Back-to-back READs may be controlled by either ADSP# or ADSC#.

**100-PIN PLASTIC TQFP
(JEDEC LQFP)**

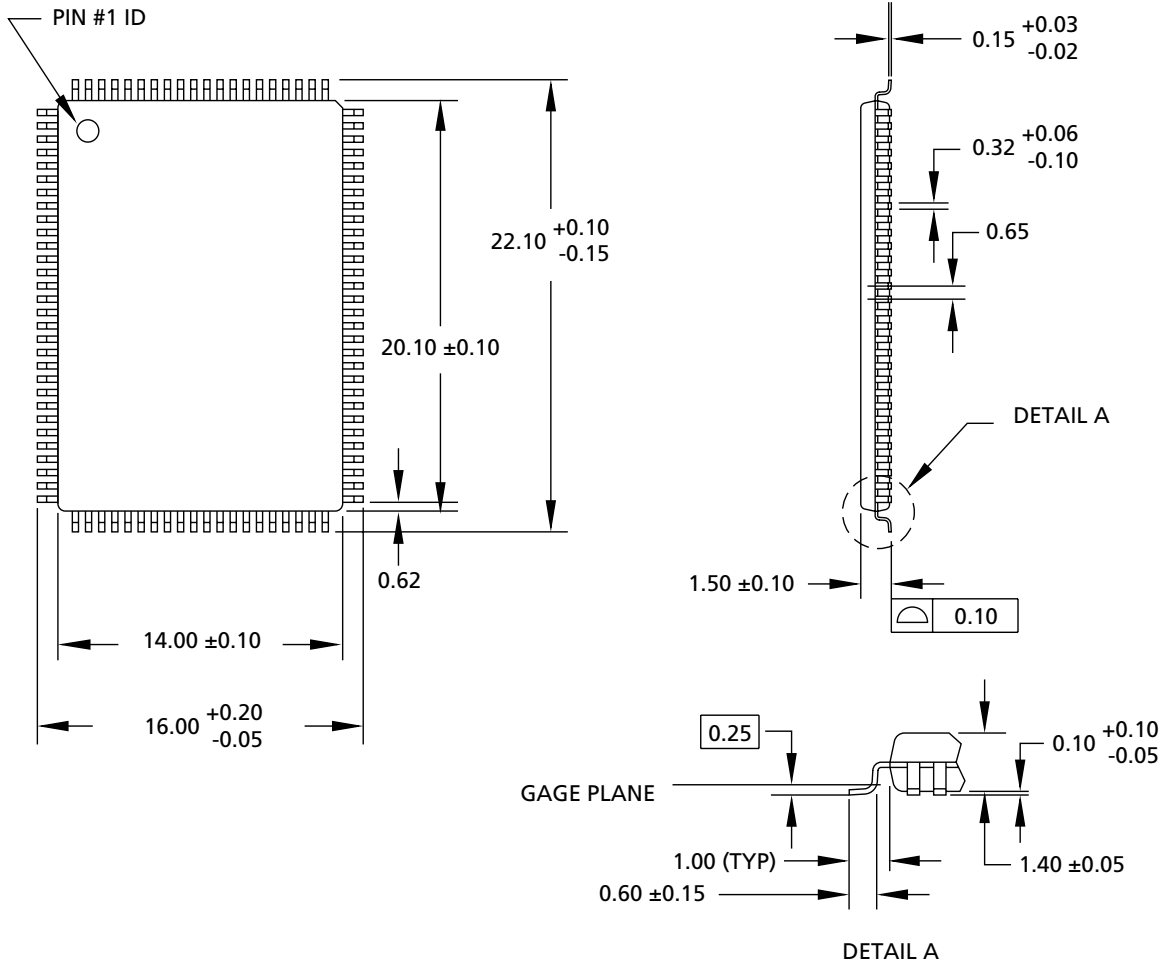

NOTE: 1. All dimensions in millimeters.
2. Package width and length do not include mold protrusion; allowable mold protrusion is 0.25mm per side.

165-PIN FBGA

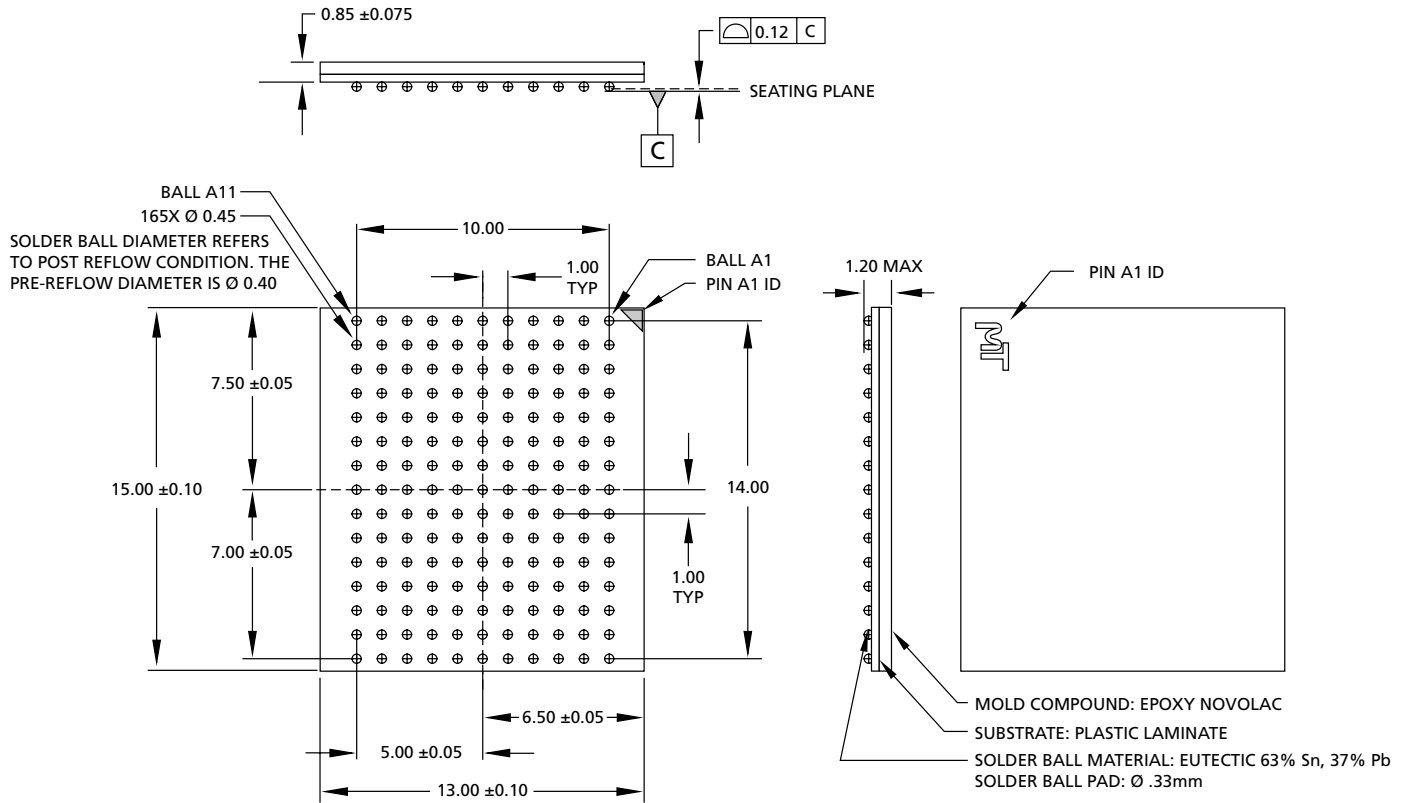

NOTE: 1. All dimensions in millimeters $\frac{\text{MAX}}{\text{MIN}}$ or typical where noted.



8000 S. Federal Way, P.O. Box 6, Boise, ID 83707-0006, Tel: 208-368-3900

E-mail: prodmktg@micron.com, Internet: <http://www.micron.com>, Customer Comment Line: 800-932-4992

Micron is a registered trademark and the Micron logo and M logo are trademarks of Micron Technology, Inc.

SyncBurst is a trademark of Micron Technology, Inc.

REVISION HISTORY

Removed "Preliminary Package Data" from front page	February 22/02
Removed 119-pin PBGA package and references	February 14/02
Removed note "Not Recommended for New Designs," Rev. 6/01	June 7/01
Added industrial temperature references and notes, Rev. 3/01	March 19/01
Changed 16Mb references to 18Mb	
Changed NC/DQP _x to NF/DQP _x	
Added 119-pin PBGA package, Rev. 1/01, FINAL	January 10/01
Removed FBGA Part Marking Guide and references, Rev. 8/00, FINAL	August 1/00
Added FBGA Part Marking Guide, Rev 7/00	July/18/00
Added Revision History	
Remove 119-Pin FBGA package and references	
Remove Industrial Temperature references	
Added 165-pin FBGA Package	June/13/00