



MB39C602

High Power Factor LED Driver IC for LED Lighting

MB39C602 is a flyback type switching regulator controller IC. The LED current is regulated by controlling the switching on-time depending on the LED load.

It is most suitable for the general lighting applications, for example stocks of commercial and residential light bulbs and so on.

Features

- High power factor in Single Conversion
- Helps to achieve high efficiency and low EMI by detecting auxiliary transformer zero current
- Switching frequency setting depend on the FC pin current : 30 kHz to 120 kHz
- Control of the current of Primary Winding without the external sense resistor
- Built-in under voltage lock out function
- Built-in output over voltage protection function
- Built-in over temperature protection function
- Input voltage range VDD : 9 V to 20 V
- Input voltage range for LED lighting applications : AC110V_{RMS}, AC230V_{RMS}
- Package : SOP-8 (3.9 mm × 5.05 mm × 1.75 mm [Max])

Applications

- LED lighting
- PWM dimmable LED lighting etc.

Contents

1. Pin Assignment	3
2. Pin Descriptions	3
3. Block Diagram	4
4. Absolute Maximum Ratings	5
5. Recommended Operating Conditions	6
6. Electrical Characteristics	7
7. Typical Characteristics	9
8. Function Explanation	11
9. Various Protection Circuits	18
10. Various Function Tables	19
11. I/O Pin Equivalent Circuit Diagram	20
12. Example Application Circuit	22
13. Reference Data	27
14. Usage Precaution	32
15. Ordering Information	33
16. RoHS Compliance Information Of Lead (Pb) Free Version	33
17. Marking Format (Lead Free version)	33
18. Labeling Sample (Lead free version)	34
19. MB39C602PNF Recommended Conditions of Moisture Sensitivity Level	35
20. Package Dimensions	37
21. Major Changes	38
Document History	39

1. Pin Assignment

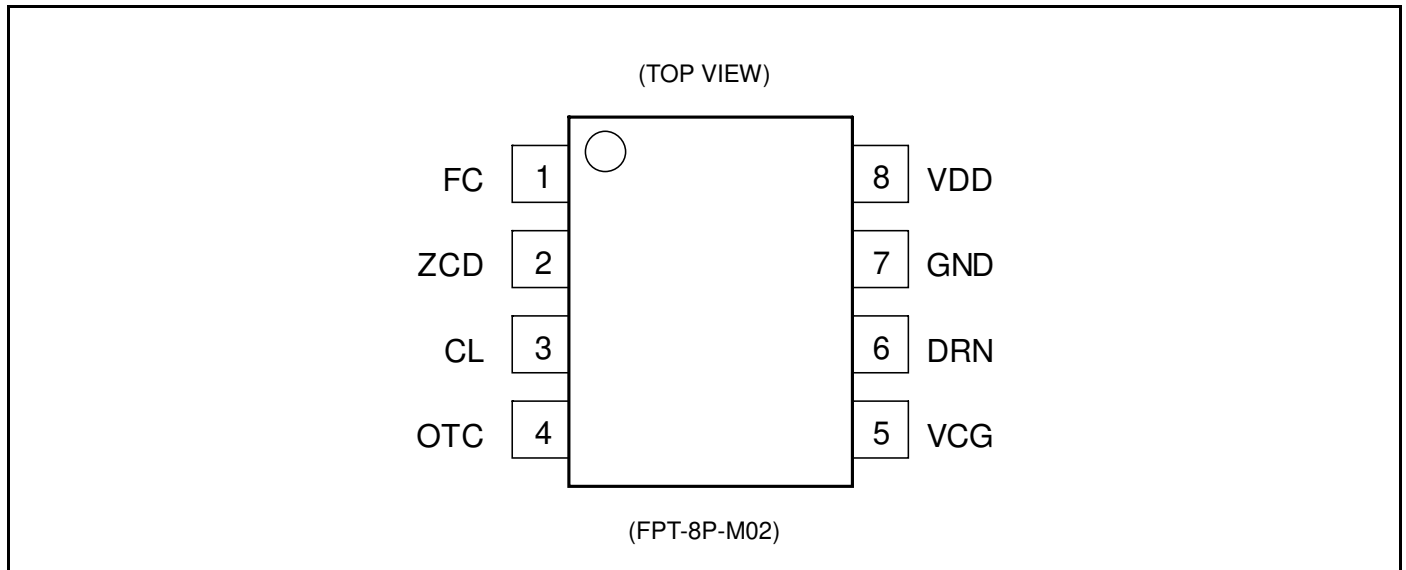

2. Pin Descriptions

Pin No.	Pin Name	I/O	Description
1	FC	I	Switching frequency setting pin.
2	ZCD	I	Transformer auxiliary winding zero current detecting pin.
3	CL	I	Pin for controlling peak current of transformer primary winding.
4	OTC	I	On-time control pin.
5	VCG	-	External MOSFET gate bias pin.
6	DRN	O	External MOSFET source connection pin.
7	GND	-	Ground pin.
8	VDD	-	Power supply pin.

3. Block Diagram

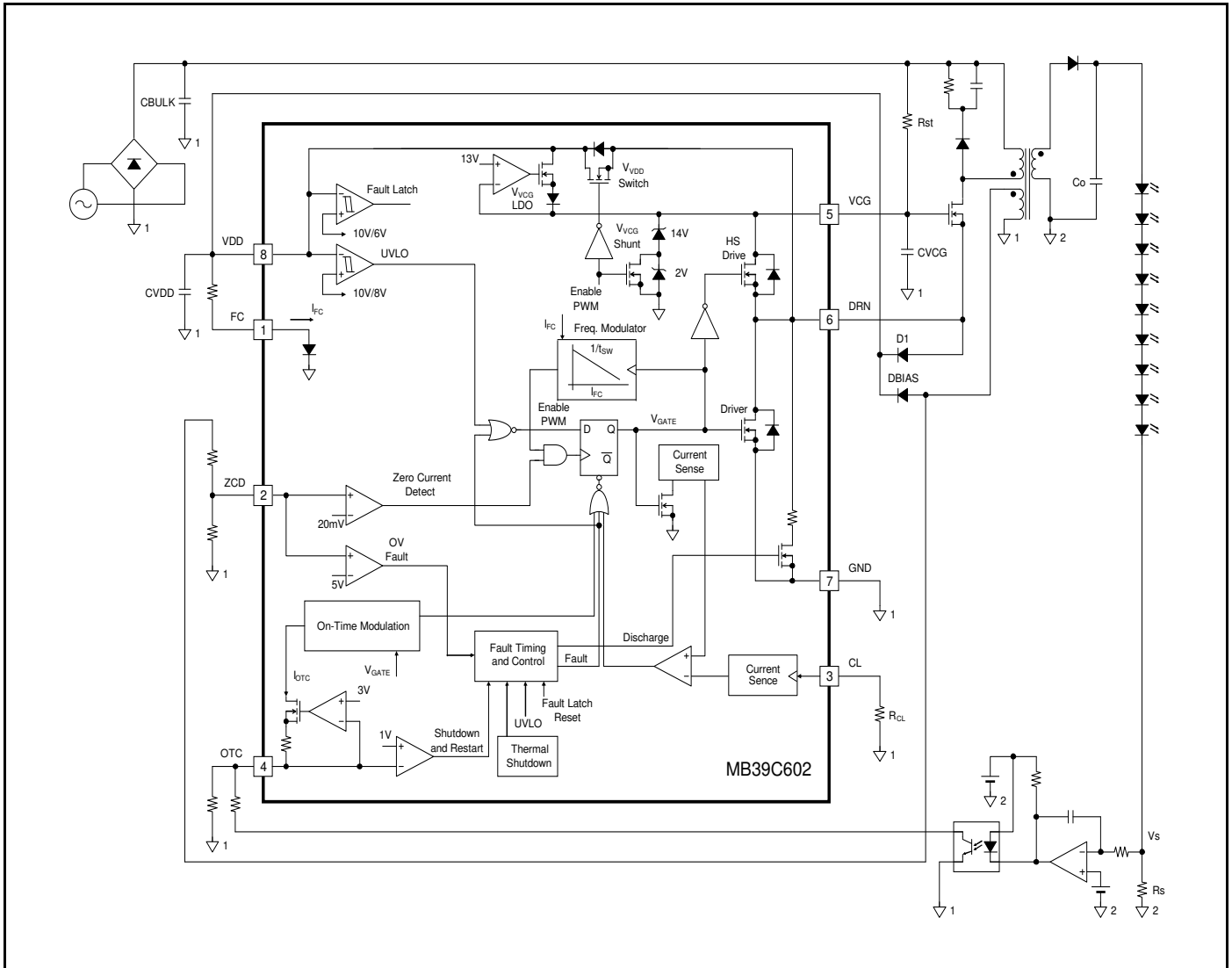

4. Absolute Maximum Ratings

Parameter	Symbol	Condition	Rating		Unit
			Min	Max	
Power supply voltage	V _{VDD}	VDD pin	-0.3	+25.0	V
Input voltage	V _{DRN}	DRN pin	-	20	V
	V _{VCG}	VCG pin	-0.3	+16.0	V
	V _{ZCD}	ZCD pin	-0.3	+6.0	V
	V _{OTC}	OTC pin	-0.3	+6.0	V
	V _{CL}	CL pin	-0.3	+6.0	V
	V _{FC}	FC pin	-0.3	+2.0	V
Input current	I _{VCG}	VCG pin	-	10	mA
	I _{OTC}	OTC pin	-1	0	mA
	I _{CL}	CL pin	-1	0	mA
	I _{FC}	FC pin	0	1	mA
Output current	I _{DRN}	DRN pin	-	800	mA
	I _{DRN}	DRN pin, Pulsed 400 ns, 2% duty cycle	-1.5	+6.0	A
Power dissipation	P _D	T _a ≤ +25°C	-	800 ^[1]	mW
Storage temperature	T _{STG}		-55	+125	°C

[1]: The value when using two layers PCB.

Reference: θ_{ja} (wind speed 0 m/s): +125°C/W

WARNING:

Semiconductor devices may be permanently damaged by application of stress (including, without limitation, voltage, current or temperature) in excess of absolute maximum ratings.

Do not exceed any of these ratings.

5. Recommended Operating Conditions

Parameter	Symbol	Condition	Value			Unit
			Min	Typ	Max	
VDD pin input voltage	VDD	VDD pin	9	-	20	V
VCG pin input voltage	VCG	VCG pin (from low-impedance source)	9	-	13	V
VCG pin input current	I _{VCG}	VCG pin (from high-impedance source)	10	-	2000	μA
OTC pin resistance to GND	R _{OTC}	OTC pin	10	-	100	kΩ
CL pin resistance to GND	R _{CL}	CL pin	24.3	-	200.0	kΩ
ZCD pin resistance to auxiliary winding	R _{ZCD}	ZCD pin Transformer auxiliary winding connection resistor	50	-	200	kΩ
VCG pin capacitance to GND	C _{VCG}	VCG pin	33	-	200	nF
VDD pin bypass capacitance	C _{BP}	Ceramic capacitance to set between VDD and GND pin	0.1	-	1.0	μF
Operating ambient temperature	T _a	-	-40	+25	+85	°C

WARNING:

The recommended operating conditions are required in order to ensure the normal operation of the semiconductor device. All of the device's electrical characteristics are warranted when the device is operated under these conditions.

Any use of semiconductor devices will be under their recommended operating condition.

Operation under any conditions other than these conditions may adversely affect reliability of device and could result in device failure.

No warranty is made with respect to any use, operating conditions or combinations not represented on this data sheet. If you are considering application under any conditions other than listed herein, please contact sales representatives beforehand.

6. Electrical Characteristics

 (Ta = +25°C, V_{VDD} = 12 V)

Parameter	Symbol	Pin No.	Condition	Value			Unit	
				Min	Typ	Max		
VDD and VCG SUPPLY	VCG voltage (Operating)	VCG _(OPERATING)	5	V _{VDD} = 14 V, I _{VCG} = 2.0 mA	13	14	15	V
	VCG voltage (Disable)	VCG _(DISABLED)	5	V _{OTC} = 0 V, I _{VCG} = 26 μA	15	16	17	V
	VCG voltage difference	ΔVCG	5	VCG _(DISABLED) - VCG _(OPERATING)	1.75	2.00	2.15	V
	VCG Shunt input current	I _{VCG (SREG)}	5	V _{VCG} = VCG _(DISABLED) - 100 mV, V _{OTC} = 0 V	-	12	26	μA
	VCG Shunt Load Regulation	ΔVCG _(SREG)	5	V _{OTC} = 0V, 26 μA < I _{VCG} ≤ 5 mA	-	125	200	mV
	VCG LDO regulation voltage	VCG _(LREG)	5	V _{VDD} = 20 V, I _{VCG} = -2 mA	-	13	-	V
	VCG LDO Dropout voltage	VCG _(LREG, DO)	-	V _{VDD} - VCG, V _{VDD} = 11 V, I _{VCG} = -2 mA	-	2.0	2.8	V
	UVLO Turn-on threshold voltage	VDD _(ON)	8	-	9.7	10.2	10.7	V
	UVLO Turn-off threshold voltage	VDD _(OFF)	8	-	7.55	8.00	8.50	V
	UVLO hysteresis	ΔVDD _(UVLO)	8	VDD _(ON) - VDD _(OFF)	1.9	2.2	2.5	V
	VDD switch on-resistance	R _{DS, ON (VDD)}	6,8	V _{VCG} = 12 V, V _{VDD} = 7 V, I _{DRN} = 50 mA	-	4 ^[1]	10 ^[1]	Ω
	Fault Latch Reset VDD voltage	VDD _(FAULT RESET)	8	-	5.6	6.0	6.4	V
MODULATION	Minimum switching period	t _{SW (HF)}	6	I _{FC} = 5 μA	7.215	7.760	8.305	μs
	Maximum switching period	t _{SW (LF)}	6	I _{FC} = 165 μA	31.5 ^[1]	35.0 ^[1]	38.5 ^[1]	μs
	DRN peak current	I _{DRN (peak)}	6	I _{FC} = 5 μA, I _{CL} = 100 μA	-	3 ^[1]	-	A
			6	I _{FC} = 5 μA, I _{CL} = 30 μA	-	1 ^[1]	-	A
	Minimum peak current for R _{CL} open	I _{DRN (peak, absmin)}	6	R _{CL} = OPEN	-	0.45 ^[1]	-	A
	ILIM blanking time	t _{BLANK (ILIM)}	6	I _{FC} = 5 μA, R _{CL} = 100 kΩ, 1.2 A pull-up on DRN	-	400 ^[1]	-	ns
	CL voltage	V _{CL}	3	I _{FC} = 5 μA	2.94	3.00	3.06	V
FC voltage	V _{FC}	1	I _{FC} = 10 μA	0.34	0.70	0.84	V	
DRIVER	Driver on-resistance	R _{DS (on) (DRN)}	6,7	I _{DRN} = 4.0 A	-	200 ^[1]	400 ^[1]	mΩ
	Driver off leakage current	I _{DRN (OFF)}	6,7	V _{DRN} = 12 V	-	1.5	20.0	μA
	High-side driver on-resistance	R _{DS (on) (HSDRV)}	5,6	High-side driver current = 50 mA	-	6 ^[1]	11 ^[1]	Ω
	DRN discharge current	I _{DIS}	6,7	V _{VDD} = OPEN, DRN = 12 V, Fault latch set	2.38	3.40	4.42	mA

Parameter	Symbol	Pin No.	Condition	Value			Unit	
				Min	Typ	Max		
TRANSFORMER ZERO CURRENT DETECTION	Zero current threshold voltage	$V_{ZCD (TH)}$	2	-	5 ^[1]	20 ^[1]	50 ^[1]	mV
	Clamp voltage	$V_{ZCD (CLAMP)}$	2	$I_{ZCD} = -10 \mu A$	-200	-160	-100	mV
	Start timer operation threshold voltage	$V_{ZCD (START)}$	2	-	0.10	0.15	0.20	V
	Driver turn-on Delay time	$t_{DLY (ZCD)}$	6	150 Ω pull-up 12 V on DRN	-	150	-	ns
	Wait time for zero current detection	$t_{WAIT (ZCD)}$	6	-	2.0	2.4	2.8	μs
	Start timer period	t_{ST}	6	$V_{ZCD} = 0 V$	150	240	300	μs
OVERVOLTAGE FAULT	OVP threshold voltage	$V_{ZCD (OVP)}$	2	-	4.85	5.00	5.15	V
	OVP blanking time	$t_{BLANK, OVP}$	6	-	0.6	1.0	1.7	μs
	Input bias current	$I_{ZCD (bias)}$	2	$V_{ZCD} = 5 V$	-0.1	0	+0.1	μA
SHUTDOWN THRESHOLD	Shutdown Threshold voltage	$V_{OTC (Vth)}$	4	OTC = 	0.7	1.0	1.3	V
	Shutdown OTC current	$I_{OTC, PU}$	4	$V_{OTC} = V_{OTC (Vth)}$	-600	-450	-300	μA
MAXIMUM ON TIME	ON-Time	t_{OTC}	6	$R_{OTC} = 76 k\Omega$	3.4	3.8	4.2	μs
	OTC voltage	V_{OTC}	4	-	2.7	3.0	3.3	V
OTP	Shutdown temperature	T_{SD}	-	T_j , temperature rising	-	+150 ^[1]	-	$^{\circ}C$
	Hysteresis	$T_{SD, HYS}$	-	T_j , temperature falling, degrees below T_{SD}	-	+25 ^[1]	-	$^{\circ}C$
POWER SUPPLY CURRENT	Power supply current	$I_{VDD (STATIC)}$	8	$V_{VDD} = 20 V, V_{ZCD} = 1 V$	1.36	1.80	2.34	mA
		$I_{VDD (OPERATING)}$	8	$V_{VDD} = 20 V$	-	3.0 ^[1]	3.7 ^[1]	mA
	Power supply current for UVLO	$I_{VDD (UVLO)}$	8	$V_{VDD} = V_{DD (ON)} - 100 mV$	-	285	500	μA

[1]: Standard design value

7. Typical Characteristics

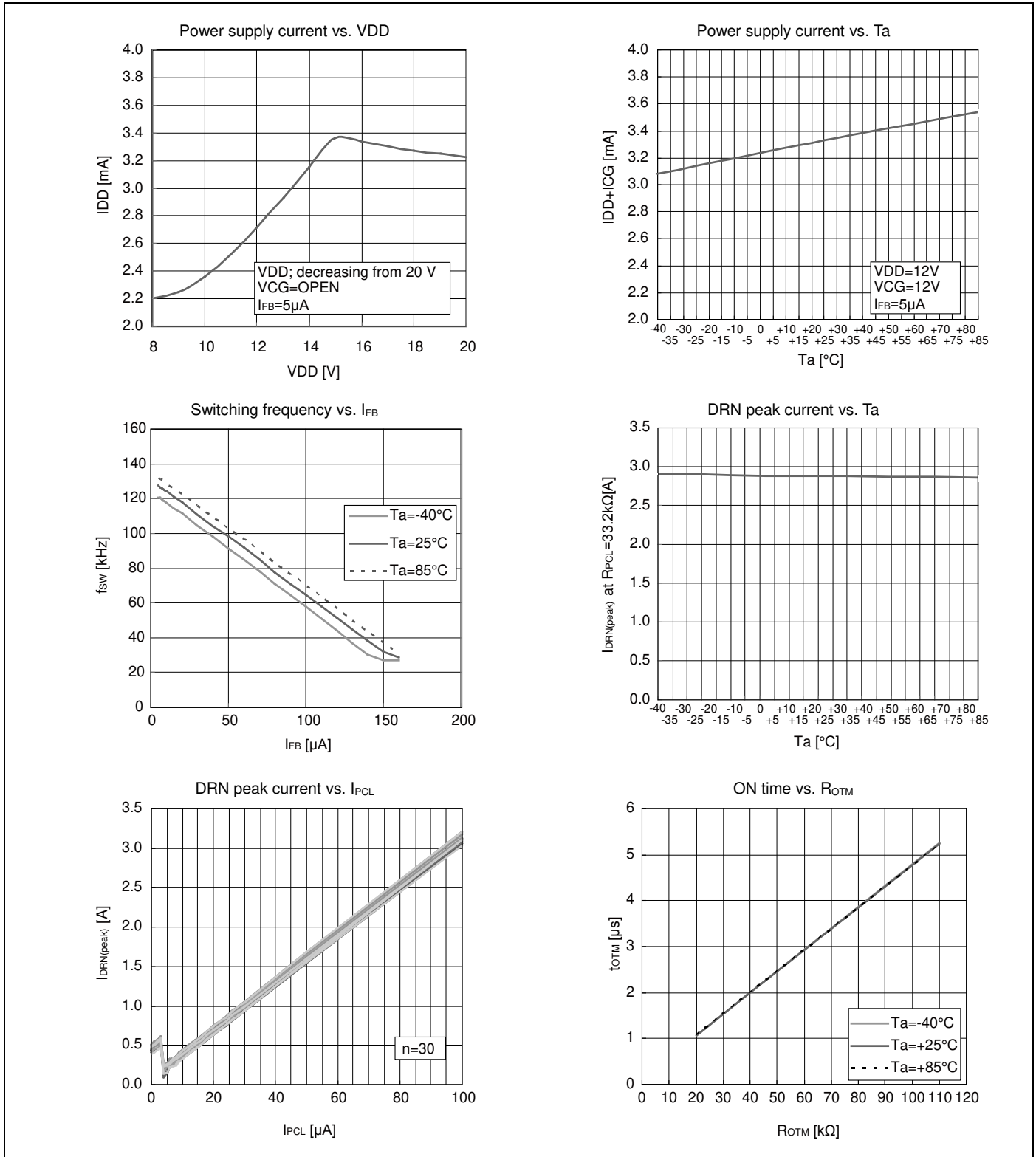

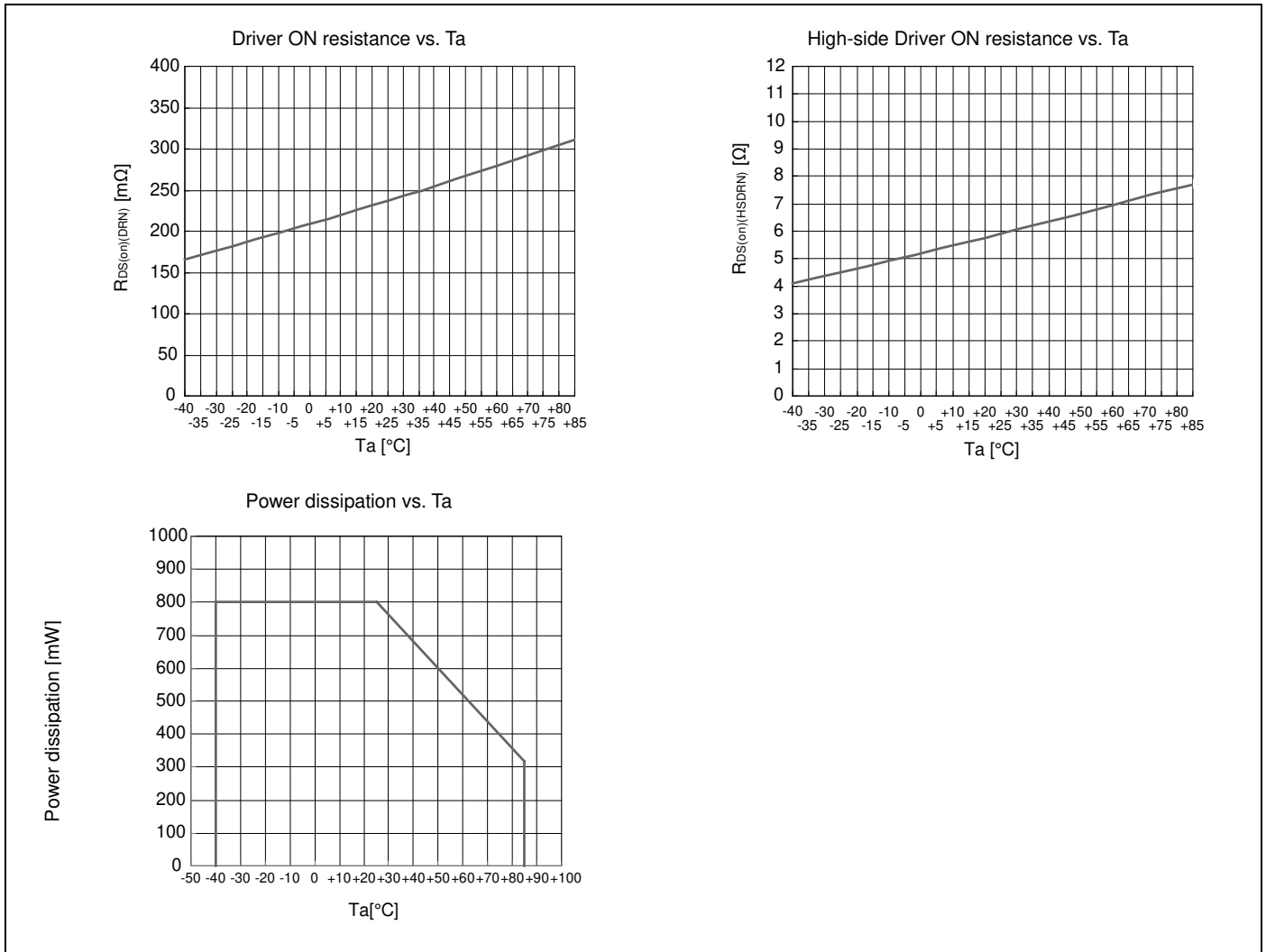

8. Function Explanation

1. LED Current Control Function

MB39C602 is a flyback type switching regulator controller. The LED current is regulated by controlling the switching on-time depending on the LED load. The LED current is converted into detecting voltage (V_s) by sense resistor (R_s) connected in series with LED. V_s is compared by an external error amplifier (Err AMP). When V_s falls below a reference voltage, Err AMP output rises and the current that flows into the Opto-Coupler is decreased.

The OTC pin current is controlled via the Opto-Coupler in the on-time control block. In on-time control, it controls on-time at OTC pin current. So, on-time increases when the current of the OTC pin decreases. And the average current supplied to LED is regulated, because on-time is regulated at the constant switching frequency.

2. Cascode Switching

The switch in Primary Winding is a cascode connection. The gate of external MOSFET is connected with the VCG pin, and the source is connected with the drain of internal Driver MOSFET. When the switch is on-state, internal Driver MOSFET is turned on, HS Driver MOSFET is turned off, and the source voltage of external MOSFET goes down to GND. For this period the DC bias is supplied to the gate of external MOSFET from the VCG pin. Therefore external MOSFET is turned on.

When the switch is off-state, internal Driver MOSFET is turned off, HS Driver MOSFET is turned on, and the source voltage of external MOSFET goes up to VCG voltage. For this period the DC bias is supplied to the gate of external MOSFET from the VCG pin. Therefore external MOSFET is turned off. Moreover, the current flowing into internal Driver MOSFET is equal to the current of Primary Winding. Therefore, the peak current into Primary Winding can be detected without the sense resistor.

3. Natural PFC (Power Factor Correction) Function

In the AC voltage input, when the input current waveform is brought close to the sine-wave, and the phase difference is brought close to Zero, Power Factor is improved. In the flyback method operating in discontinuous conduction mode, when the input capacitance is set small, the input current almost becomes equal with peak current (I_{PEAK}) of Primary Winding.

$$I_{PEAK} = \left(\frac{V_{BULK} \times t_{ON}}{L_{MP}} \right) = \left(\frac{V_{BULK}}{\left(\frac{L_{MP}}{t_{ON}} \right)} \right)$$

V_{BULK} : Supply voltage of Primary Winding
 L_{MP} : Inductance of Primary Winding
 t_{ON} : On-time

In on-time control, if loop response of Error Amp. is set to lower than the AC frequency (below 1/10 of the AC frequency), on-time can be constant. Therefore, input current is proportional to input voltage, so Power Factor is regulated.

4. Power-Up Sequencing

When the voltage is input to VBULK, the electric charge is charged to capacitance of the VCG pin (CVCG) through starting resistor (Rst). So, the voltage of the VCG pin rises. The voltage of the DRN pin rises by source follower when the voltage of the VCG pin reaches the threshold voltage of the external HV MOSFET.

The DRN pin is connected with the VDD pin through the internal VDD Switch, and VDD capacitor (CVDD) is charged from the DRN pin. When the voltage at the VDD pin reaches the threshold voltage of UVLO, the VDD Switch is turned off, and the internal Bias circuit operates, and the switching is started.

After the switching begins, the voltage at the VDD pin is supplied from Auxiliary Winding through the external diode (DBIAS). The voltage of an Auxiliary Winding is decided by rolling number ratio of Auxiliary Winding and Secondary Winding, and the voltage of Secondary Winding. Therefore, the voltage at the VDD pin is not supplied, until the voltage of Auxiliary Winding rises more than the voltage at the VDD pin. In this period, it is necessary to set the capacitor of the VDD pin to prevent the voltage of the VDD pin from falling below the threshold voltage of UVLO.

The external Schottky diode (D1) is required between the DRN pin and VDD pin. This diode is used to prevent the current that flows through the body diode of the VDD Switch.

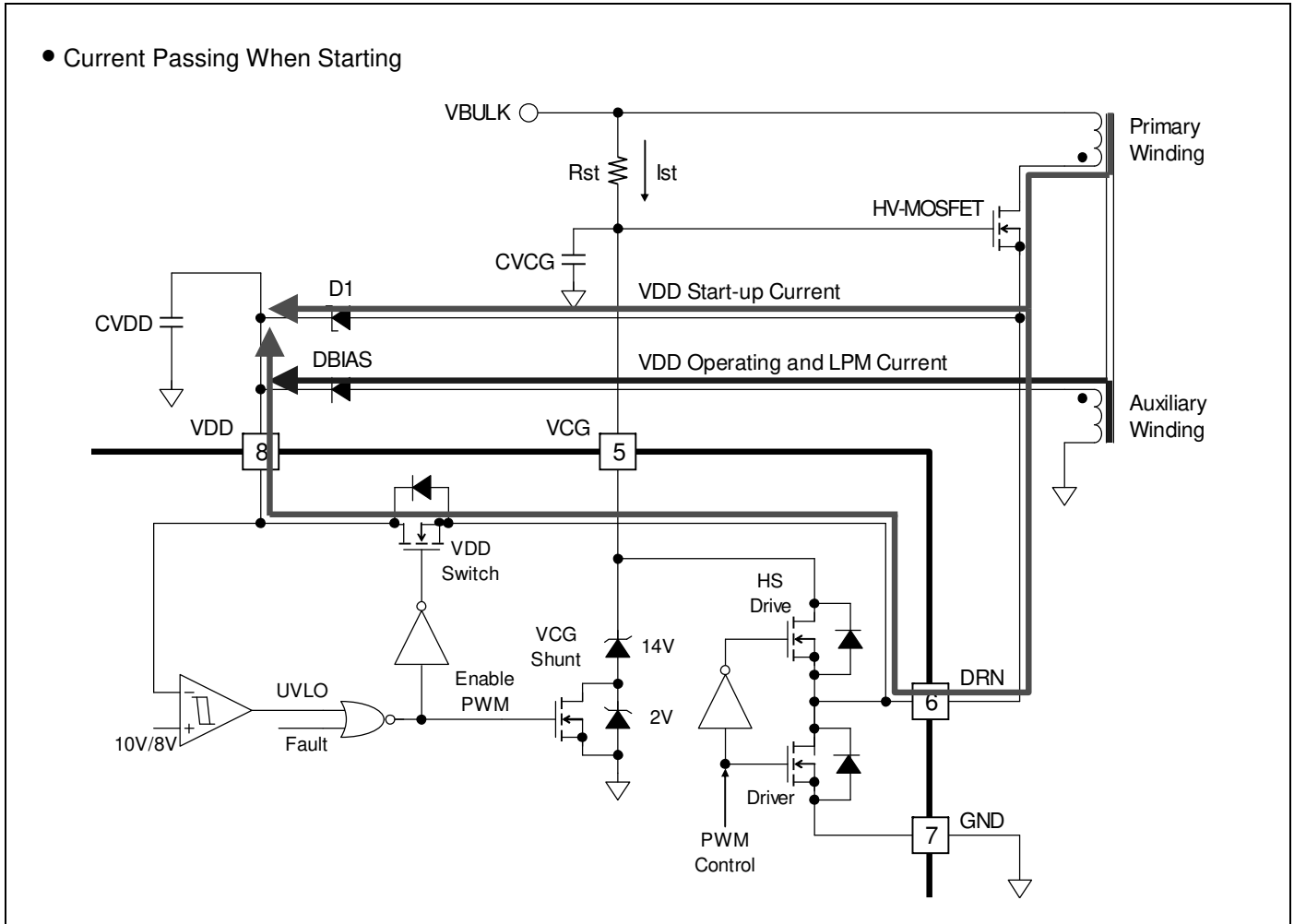

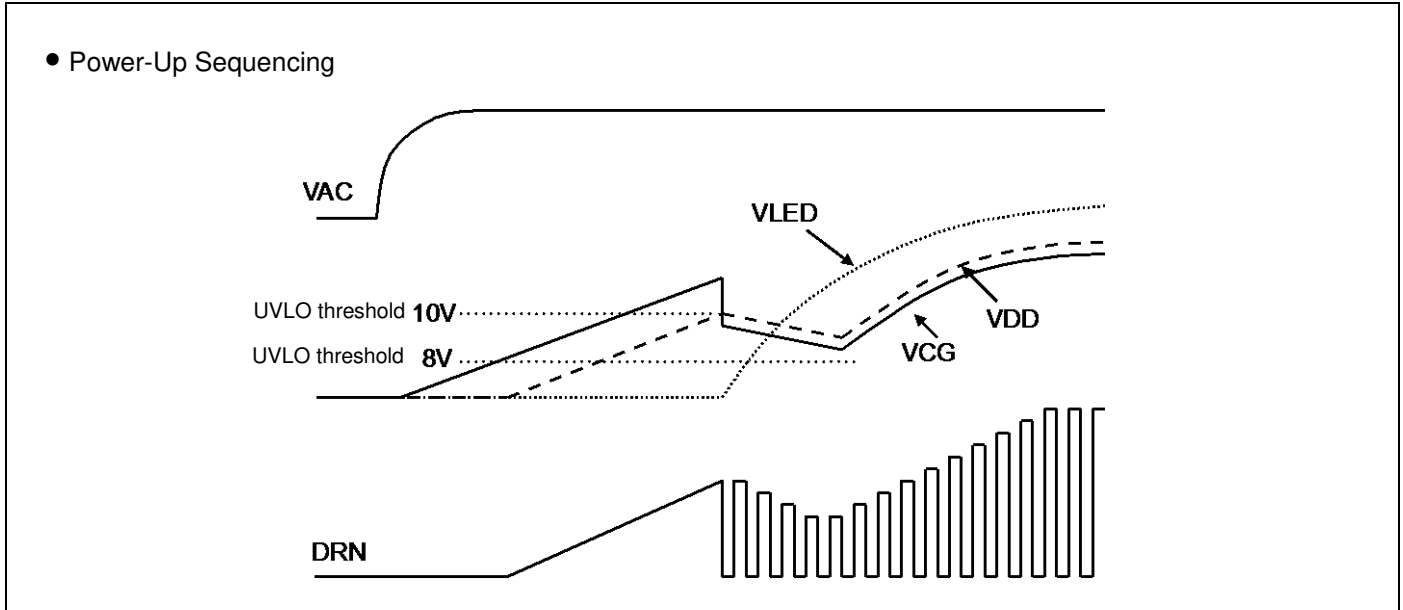

5. Power Down Sequencing

When AC power is removed from the AC line, the current does not flow to Secondary Winding even if HV MOSFET is switching. The LED current is supplied from the output capacitance and decreases gradually. Similarly, the voltage at the VDD pin decreases because the current does not flow into Auxiliary Winding. The switching stops and MB39C602 becomes shutdown when the voltage at the VDD pin falls below the threshold voltage of UVLO.

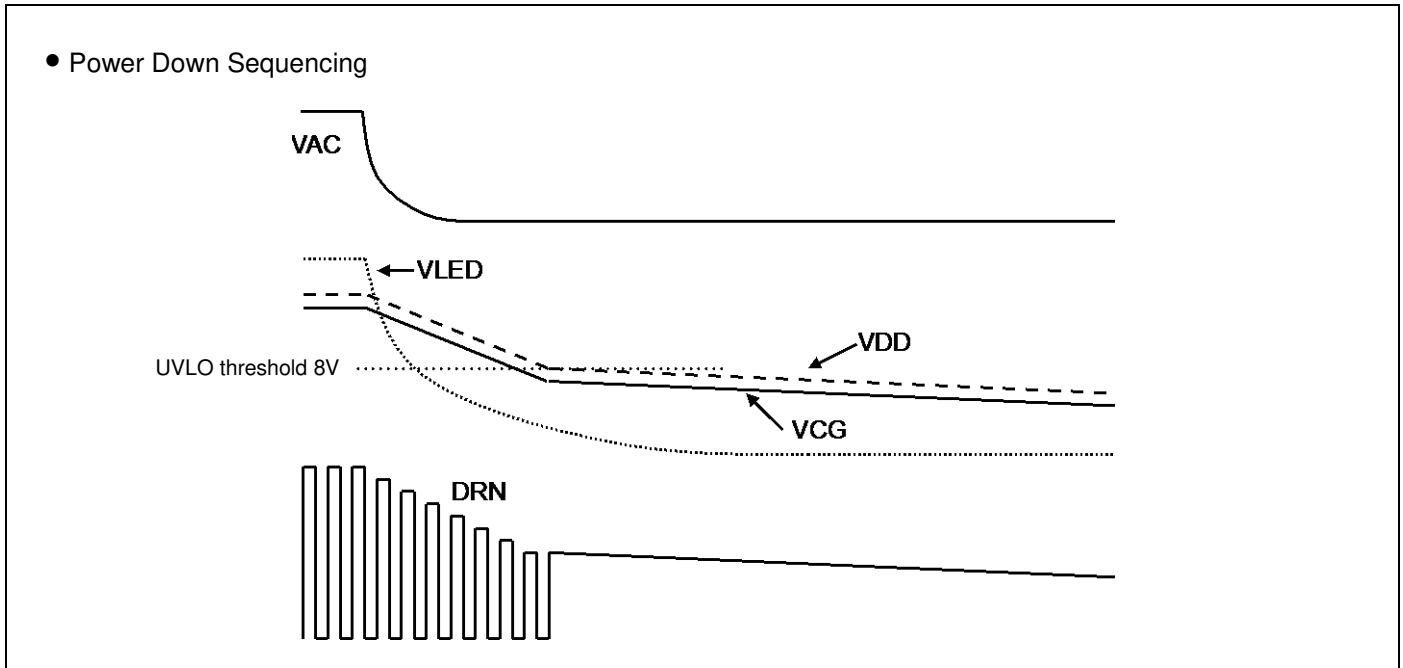

6. OTC Part

It is set on-time by connecting resistance (R_{OTC}) with OTC pin.

As shown in following figure, the on-time can be controlled by connecting the collector of the Opto-Coupler through resistor from OTC.

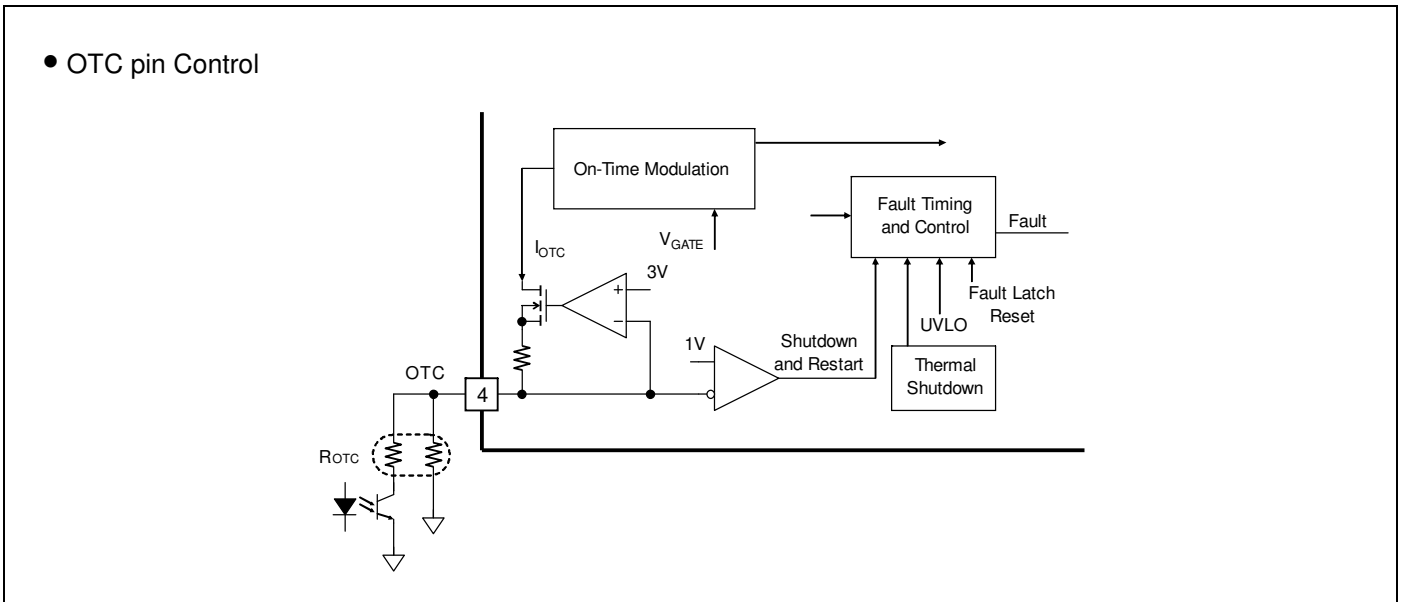

The following figure shows how the on-time is programmed over the range of between 1.5 μs and 5.0 μs for either range of programming resistors. On-time is related to the programmed resistor based on the following equations.

$$R_{OTC} = t_{OTC} \times (2 \times 10^{10} \left[\frac{\Omega}{\text{S}} \right])$$

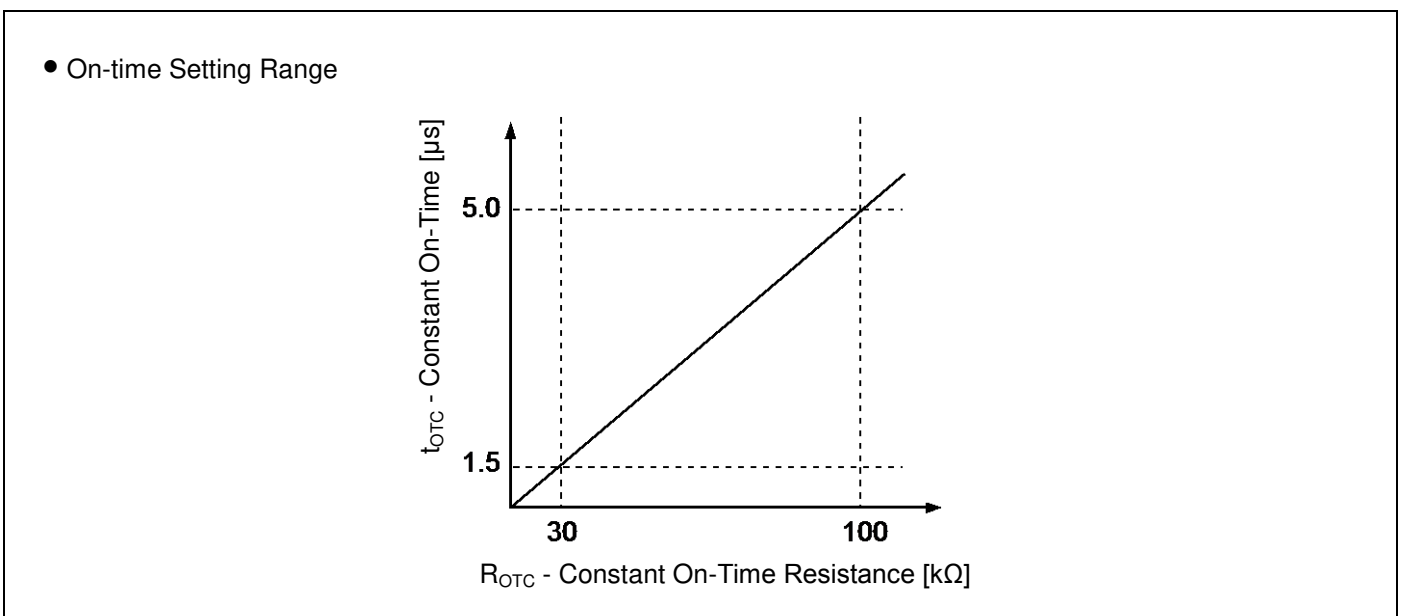

Moreover, it can be shutted down by making the voltage of the OTC pin below " $V_{OTC(Vth)}$ (typ 1V)".

7. CL Part

It is set the peak current of Primary Winding by connecting resistance with CL pin.

The maximum peak current of Primary Side is set by connecting resistance (R_{CL}) between the CL pin and GND.

$$I_{DRN(pk)} = \left(\frac{100kV}{R_{CL}} \right)$$

An about 400 ns blanking time of the beginning of switching cycle is masking the spike noise. As a result, it prevents the sense of current from malfunctioning (See the figure below.).

• Peak Current Control with CL pin

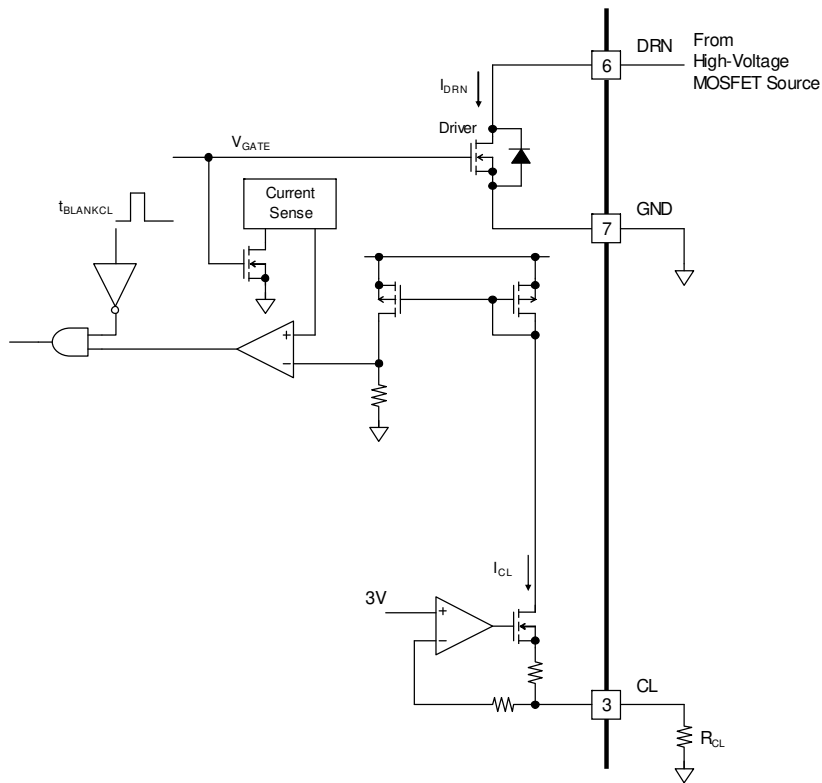

8. FC Part

The switching frequency is controlled by setting the current of the FC pin. In on-time control, the switching frequency is set by pulling up the FC pin to VDD.

Switching frequency range is from 30 kHz to 120 kHz.

- Switching Frequency Range

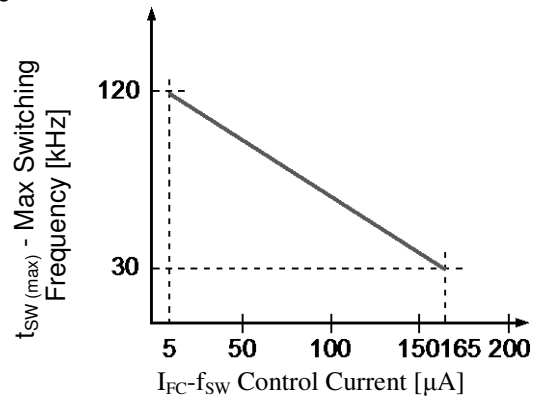

9. ZCD Part

MB39C602 requires the following two conditions in order to start the next switching cycle.

- (1) The time since the last turn-on edge must be equal to or longer than the switching time set by I_{FC} .
- (2) Immediately after zero current detection at ZCD pin. Or, the time since the last zero current detection must be longer than $t_{WAIT(ZCD)}$ (2.4 μ s or less).

The ZCD pin is connected with Auxiliary Winding of the transformer through the resistance division, and detects zero current as shown below.

A delay, 50 ns to 200 ns, can be added with C_{ZCD} to adjust the turn-on of the primary switch with the resonant bottom of Primary Winding waveform.

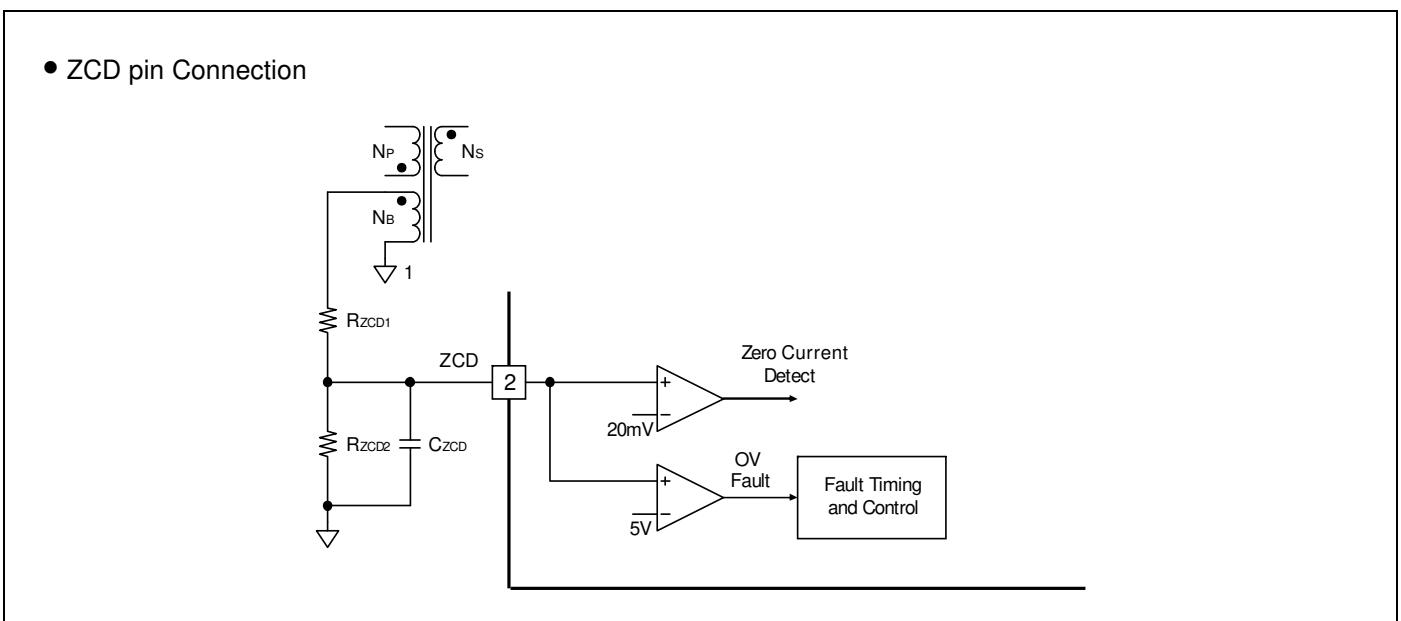
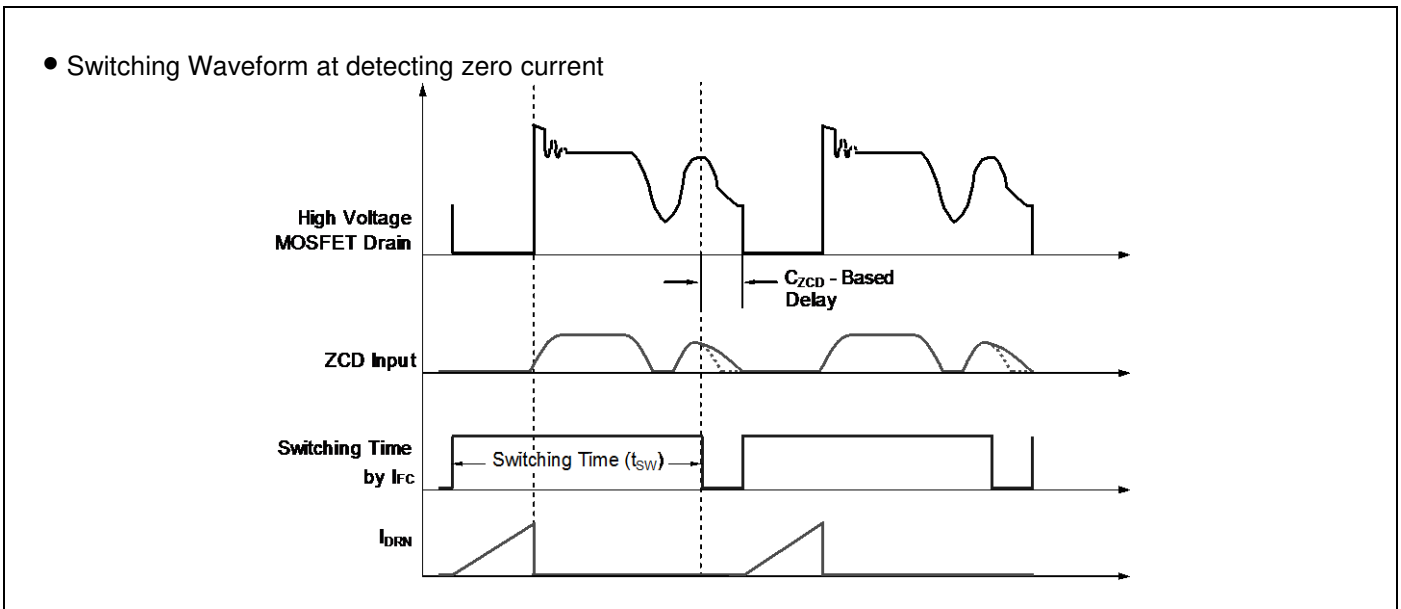

9. Various Protection Circuits

■ Under voltage lockout protection (UVLO)

The under voltage lockout protection (UVLO) protects IC from malfunction and protects the system from destruction/deterioration during the transient state and momentary drop due to start up for the power supply pin voltage (VDD). The voltage decrease of the VDD pin is detected with comparator, and output HS DRIVER is turned off and output DRIVER is turned off, and the switching is stopped. The system returns if the VDD pin becomes more than the threshold voltage of the UVLO circuit.

■ Output over voltage Protection (OVP)

When LED is in the state of open and the output voltage rises too much, the voltage of Auxiliary Winding and the voltage of the ZCD pin rise. The over voltage is detected by sampling this voltage of the ZCD pin.



When ZCD pin voltage rises more than the threshold voltage of OVP, the over voltage is detected. Output HS DRIVER is turned off, and output DRIVER is turned off, and the switching is stopped. (latch-off)

If the VDD pin becomes below the voltage of Fault Latch Reset, OVP is released.

■ Over temperature protection (OTP)

The over temperature protection (OTP) is a function to protect IC from the thermal destruction. When the junction temperature reaches +150°C, output HS DRIVER is turn off, and output DRIVER is turned off, and the switching is stopped. It returns again when the junction temperature falls to +125°C (automatic recovery).

10. Various Function Tables

Function	DRN				Detection Condition at Protected Operation	Return Condition	Remarks
	LS_DRV	HS_DRV	VDD SW	Discharge SW			
Normal Operation			OFF	OFF	-	-	-
Under Voltage Lockout Protection (UVLO)	OFF	OFF	ON	OFF	VDD < 8.0 V	VDD > 10.2 V	Standby
OTC Shutdown	OFF	OFF	ON	OFF	OTC = GND	OTC > 1 V	Standby
Output Over Voltage Protection (OVP)	OFF	OFF	ON	ON	ZCD > 5 V	VDD < 6 V → VDD > 10.2 V	Latch-off
Over Temperature Protection (OTP)	OFF	OFF	ON	OFF	T _j > +150°C	T _j < +125°C	-

11. I/O Pin Equivalent Circuit Diagram

Pin No.	Pin Name	Equivalent Circuit Diagram
1	FC	
2	ZCD	
3	CL	

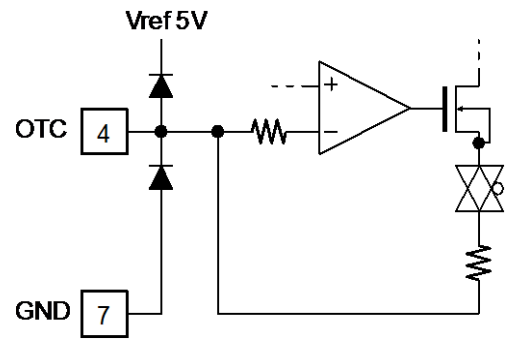
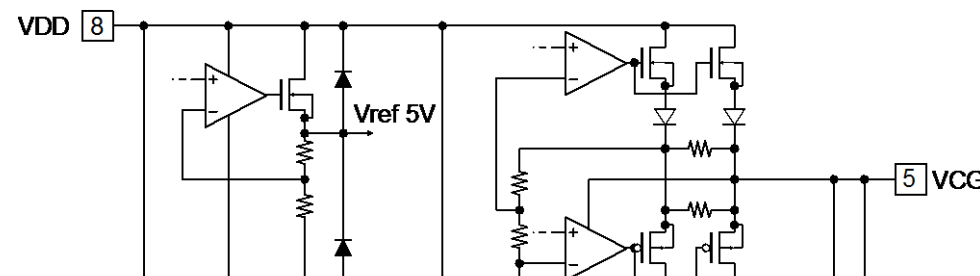
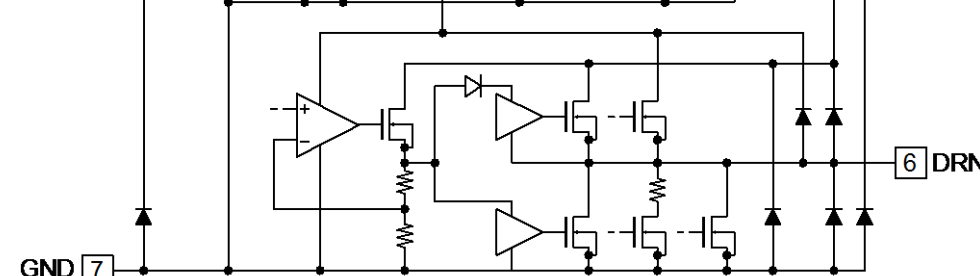
Pin No.	Pin Name	Equivalent Circuit Diagram
4	OTC	
5	VCG	
6	DRN	

12. Example Application Circuit

1. Isolation circuit

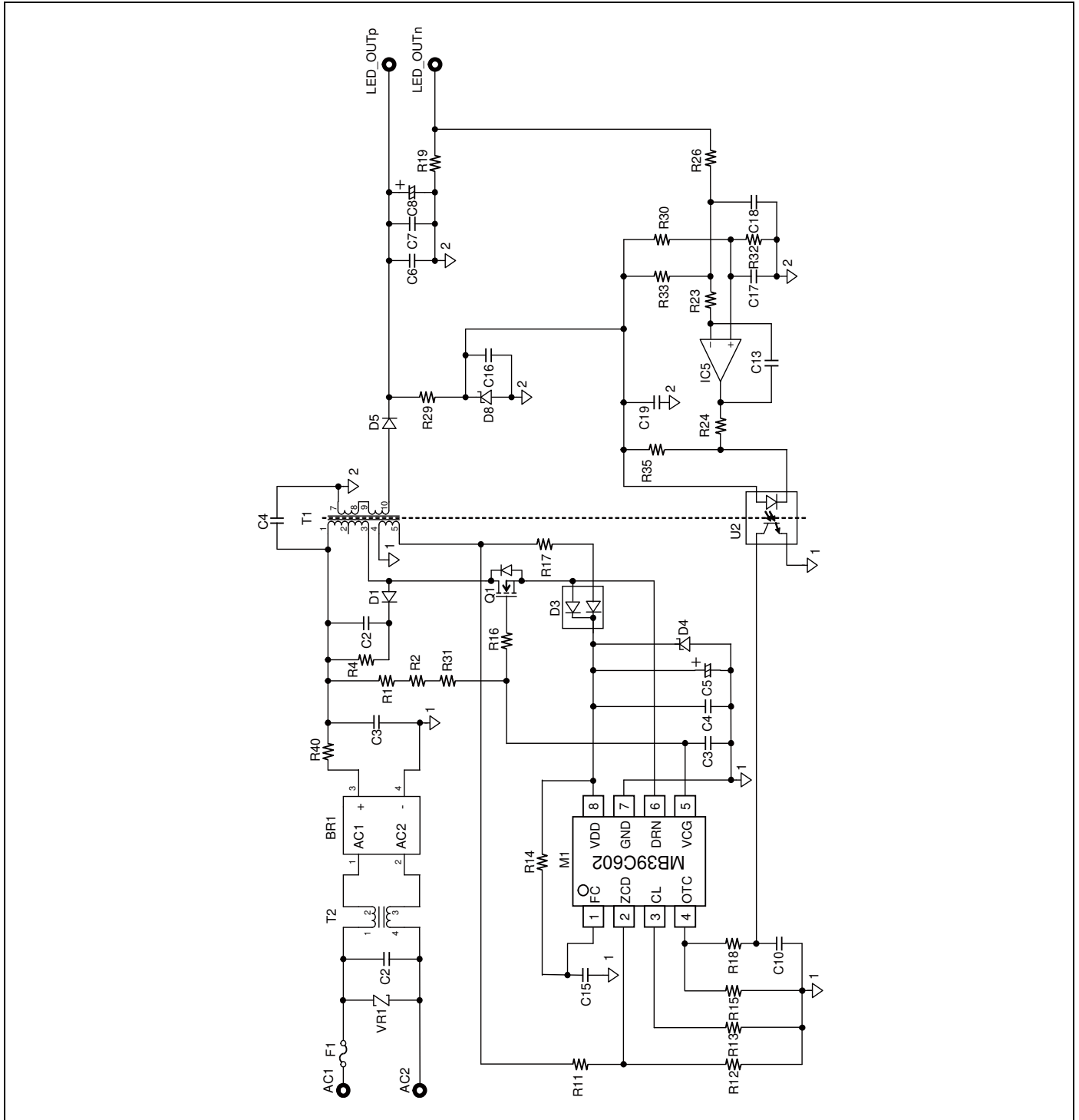

2. Non-isolation circuit

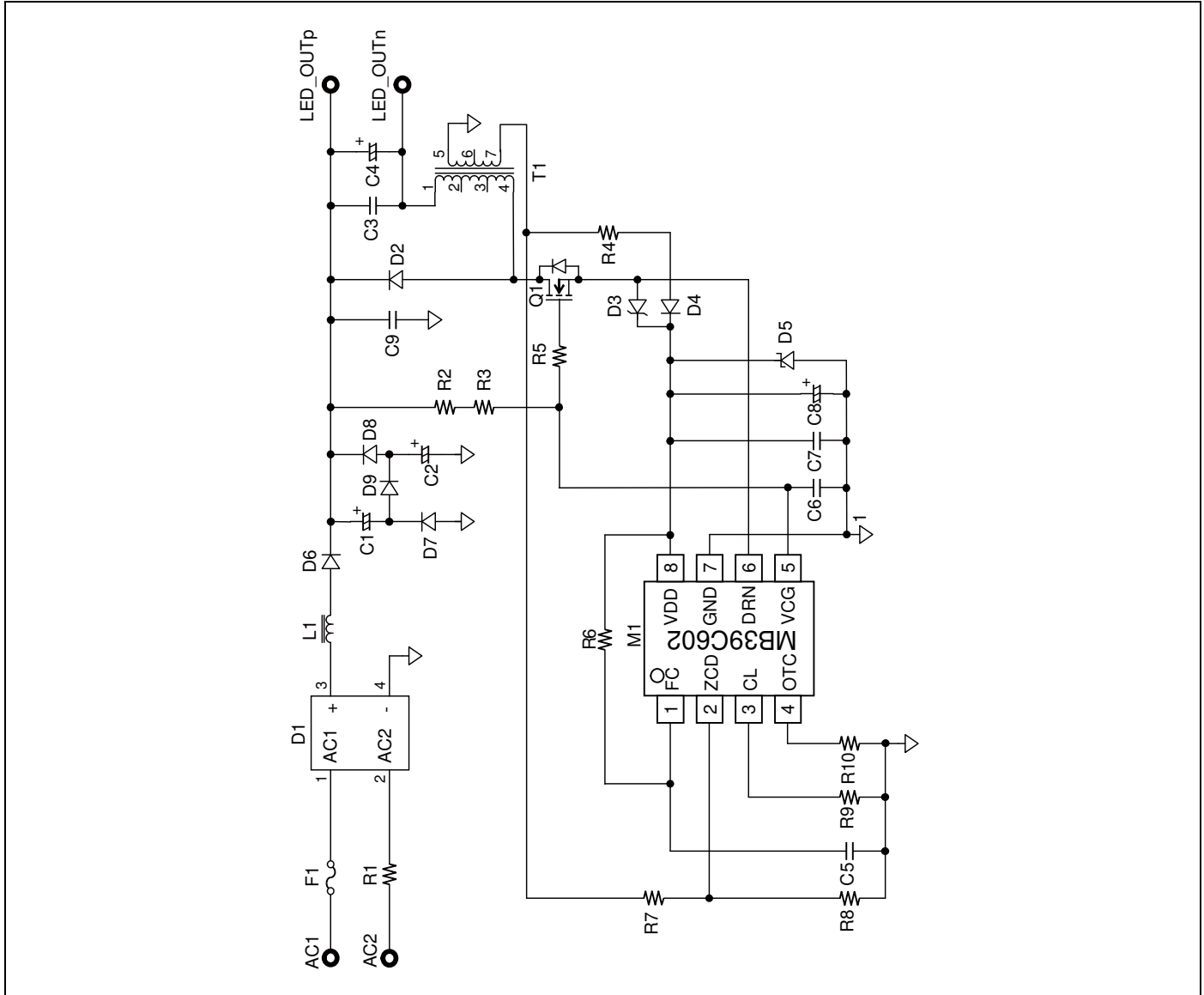

Part list

1. Isolation circuit

No	Component	Description	Part No.	Vendor
1	M1	IC PWM CTRLR CASCODE 8-SOIC	MB39C602	Cypress
2	T1	TRANSFORMER FLYBACK EE20/10/6 430 µH 1.6 A RATIO Np/Ns=2.91/1 Np/Na=6.4/1	750811146	Würth
3	T2	IND COMMON MODE CHOKE 40 mH	750311650	Würth
4	F1	Fuse, axial, fast acting, 2.5 A, 250 V, 0.160 × 0.400 inch	026302.5MXL	Littelfuse Inc
5	IC5	IC OPAMP GP R-R 1MHz SGL SOT23-5	LMV321IDBVR	Texas Instruments
6	Q1	MOSFET N-ch 650 V 7.3 A TO-220 FP	SPA07N60C3	Infineon
7	U2	OPTO ISOLATOR TRANSISTOR OUTPUT	PS2561L-1-A	CEL
8	BR1	IC RECT BRIDGE 0.5 A 600 V 4SOIC	MB6S	Fairchild
9	D1	DIODE ULTRA FAST 800 V 1 A SMA	RS1K-13-F	Diodes
10	D3	DIODE ULTRA FAST 200 V SOT-23	MMBD1404	Fairchild
11	D4	DIODE ZENER 18 V 225 mW SOT-23	BZX84C18LT1G	On Semi
12	D5	DIODE GPP FAST 1 A 600 V DO-41	UF4005	Fairchild
13	D8	SHUNT REGULATOR 5.0 V SOT-23	LM4040C50IDBZT	Texas Instruments
14	VR1	SUR ABSORBER 7 mm 430 V 1250 A ZNR	ERZ-V07D431	Panasonic
15	C2	CAP CER 15000 pF 250 V X7R 1206	GRM31BR72E153KW01L	muRata
16	C3	CAP CER 10000 pF 50 V X7R 0603	GRM188R71H103KA01D	muRata
17	C4	CAP CER .1 µF 25 V X7R 10% 0603	GRM188R71E104KA01D	muRata
18	C5	CAP 100 µF 25 V ELECT RADIAL 2.5 mm	EKMG250ELL101MF11D	Nippon Chemi-con
19	C6, C7	CAP CER 2.2 µF 100 V X7R 1210	GRM32ER72A225KA35	muRata
20	C8	CAP 1000 µF 50 V ELECT HE RADIAL	EKMG500ELL102MK25S	Nippon Chemi-con
21	C9	CAP .022 µF/630 VDC METAL POLY	ECQE6223KF	Panasonic
22	C10, C15, C17, C18, C19	CAP CER 10000 pF 50 V X7R 0603	GRM188R71H103KA01D	muRata
23	C11	CAP CER 2.2 nF X1/Y1 RADIAL	DE1E3KX222MA4BL01	muRata
24	C13	CAP CER 0.33 µF 16 V X7R 0603	C0603C334K4RACTU	Kemet
25	C16	CAP CER .1 µF 25 V 0805	GRM21BR71E104KA0	muRata
26	C21	CAP .022 µF/305 VAC X2 METAL POLYPRO	B32921C3223M	Epcos
27	R1, R2, R31	RES 560 kΩ 1/4W 1% 1206 SMD	RK73H2BTDD5603F	KOA
28	R4	RES 75.0 kΩ 1/4 W 1% 1206 SMD	RK73H2BTDD7502F	KOA
29	R11	RES 110 kΩ, 1/8 W, 1%, 0603 SMD	RK73H1JTDD1103F	KOA
30	R12	RES 33 kΩ 1/10 W 1% 0603 SMD	RK73H1JTDD3302F	KOA

No	Component	Description	Part No.	Vendor
31	R13	RES 39 kΩ 1/10 W 1% 0603 SMD	RK73H1JTDD3902F	KOA
32	R14, R30	RES 620 kΩ 1/10 W 1% 0603 SMD	RK73H1JTDD6203F	KOA
33	R15	RES 100 kΩ 1/10 W 1% 0603 SMD	RK73H1JTDD1003F	KOA
34	R16	RES 5.1 Ω 1/10 W 1% 0603 SMD	RK73H1JTDD5R10F	KOA
35	R17	RES 3 Ω 1/8 W 1% 0805 SMD	RK73H2ATTD3R00F	KOA
36	R18	RES 10.0 kΩ 1/10 W 1% 0603 SMD	RK73H1JTDD1002F	KOA
37	R19	RES .33 Ω 1/4 W 1% 1206 SMD	ERJ-8RQFR33V	Panasonic
38	R23	RES 20 kΩ 1/10 W 1% 0603 SMD	RK73H1JTDD2002F	KOA
39	R24, R35	RES 3 kΩ 1/10 W 1% 0603 SMD	RK73H1JTDD3001F	KOA
40	R33	RES 1.00 MΩ 1/10 W 1% 0603 SMD	RK73H1JTDD1004F	KOA
41	R26	RES 2.00 kΩ 1/10 W 1% 0603 SMD	RK73H1JTDD2001F	KOA
42	R29	RES 12 kΩ 1/10 W 1% 0603 SMD	RK73H1JTDD1202F	KOA
43	R32	RES 18 kΩ 1/10 W 1% 0603 SMD	RK73H1JTDD1802F	KOA
44	R40	JUMPER (RES 0.0 Ω 1210)	RK73Z2E	KOA

Würth : Adolf Würth GmbH & Co. KG
 Texas Instruments : Texas Instruments, Inc
 Infineon : Infineon Technologies AG
 CEL : California Eastern Laboratories, Inc
 Fairchild : Fairchild Semiconductor International, Inc.
 Diodes : Diodes, Inc
 On Semi : ON Semiconductor
 Panasonic : Panasonic Corporation
 muRata : Murata Manufacturing Co., Ltd.
 Nippon Chemi-con : Nippon Chemi-Con Corporation
 Kemet : KEMET Electronics Corporation
 Epcos : EPCOS AG
 KOA : KOA Corporation

2. Non-isolation circuit

No	Component	Description	Part No.	Vendor
1	IC	Driver IC for LED Lighting, SOL8	MB39C602	Cypress
2	C1	Capacitor, aluminum electrolytic, 47 μ F, 250 V, 12.5 x 20	EKXG251ELL470MK20S	Nippon Chemi-con
3	C2			
4	C3	Capacitor, ceramic, 10 μ F, 50 V, X7R, +/-10%, 1210	GRM32DF51H106ZA01L	muRata
5	C4	Capacitor, aluminum electrolytic, 100 μ F, 50 V, 8 x 11.5	EKMG500ELL101MHB5D	Nippon Chemi-con
6	C5, C6	Capacitor, ceramic, 0.01 μ F, 50 V, X7R, +/-10%, 0603	GRM188R71H103KA01D	muRata
7	C7	Capacitor, ceramic, 0.1 μ F, 25 V, X7R, +/-10%, 0603	GRM188R71E104KA01D	muRata
8	C8	Capacitor, aluminum electrolytic, 100 μ F, 25 V, 6.3 x 11	EKMG250ELL101MF11D	Nippon Chemi-con
9	C9	Capacitor, polyester film, 0.22 μ F, 250 V, 12 x 5.5 x 10.5	ECQ-E2224KF	Panasonic
10	D1	Diode, bridge rectifier, 0.5 A, 600 V, SO-4	MB6S	Fairchild
11	D2	Diode, ultra fast rectifier, 1 A, 400 V, SMA	ES1G	Fairchild
12	D3	Diode, Schottky, 1 A, 30 V, SOD-323	SDM100K30	Diodes
13	D4	Diode, ultra fast, 1 A, 200 V, SMA	CSFA103-G	On Semi
14	D5	Diode, Zener, 18 V, 500 mW, SOD-123	MMSZ18T1G	On Semi
15	D6, D7	Jumper	RK73ZW2H	KOA
16	D8, D9			
17	F1	Fuse, axial, fast acting, 2.5 A, 250 V, 0.160 inch x 0.400 inch	026302.5MXL	Littelfuse Inc
18	L1	Inductor, 100 μ H, 0.67 A max, 0.39 Ω max	22R104C	muRata Ps
19	T1	Coupling inductor, 280 μ H, 1.4 A, Na/Nm=0.6	EI-191-03377-T	SUMIDA
20	Q1	MOSFET, N-ch, 650 V, 7.3 A, 0.6 W, TO-220	FDPF10N60NZ	Fairchild
21	R1	NTC thermistor, 8.0 Ω , 1.5 A	NTPA78R0LBMBO	muRata
22	R2, R3	Resistor, chip, 1.00 M Ω , 1/8 W, +/-1%, 0805	RK73H2ATTD1004F	KOA
23	R4	Resistor, chip, 3.0 Ω , 1/8 W, +/-1%, 0805	RK73H2ATTD3R00F	KOA
24	R5	Resistor, chip, 5.1 Ω , 1/10 W, +/-1%, 0603	RK73H1JTDD5R10F	KOA
25	R6	Resistor, chip, 1.00 M Ω , 1/10 W, +/-1%, 0603	RK73H1JTDD1004F	KOA
26	R7	Resistor, chip, 110 k Ω , 1/10 W, +/-1%, 0603	RK73H1JTDD1103F	KOA
27	R8	Resistor, chip, 33 k Ω , 1/10 W, +/-1%, 0603	RK73H1JTDD3302F	KOA
28	R9	Resistor, chip, 91 k Ω , 1/10 W, +/-1%, 0603	RK73H1JTDD9102F	KOA
29	R10	Resistor, chip, 100 k Ω , 1/10 W, +/-1%, 0603	RK73H1JTDD1003F	KOA

Nippon Chemi-con : Nippon Chemi-Con Corporation

muRata : Murata Manufacturing Co., Ltd.

Panasonic : Panasonic Corporation

Fairchild : Fairchild Semiconductor International, Inc.

Diodes : Diodes, Inc

On Semi : ON Semiconductor

KOA : KOA Corporation

muRata Ps : Murata Power Solutions, Inc

SUMIDA : SUMIDA CORPORATION.

13. Reference Data

1. Isolation circuit

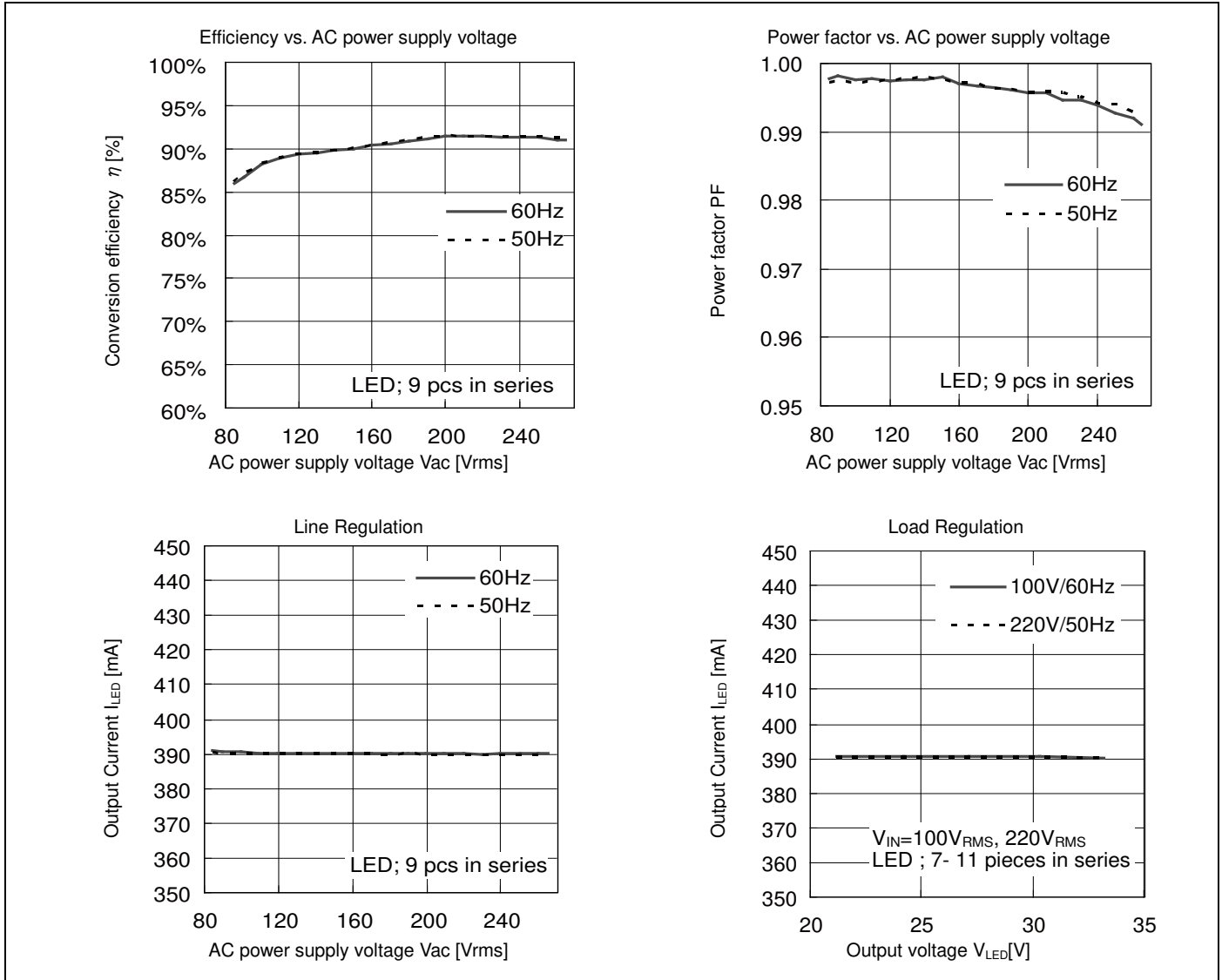

$V_{IN}=100V_{RMS}$, 60 Hz, LED; 9 pcs in series

I/O waveform

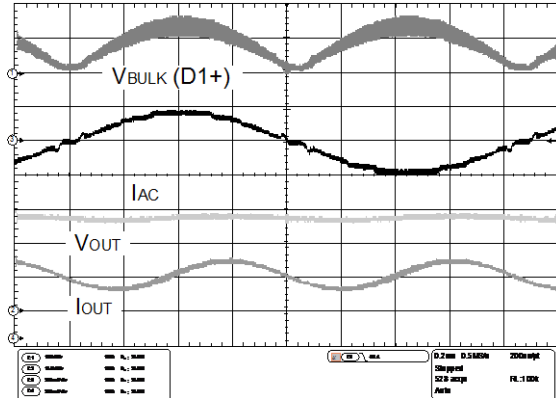

Switching waveform

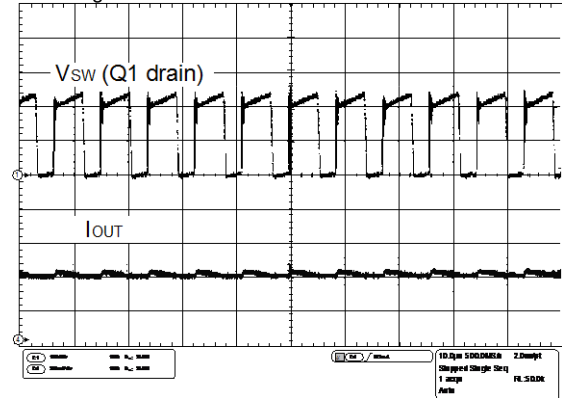

Startup waveform

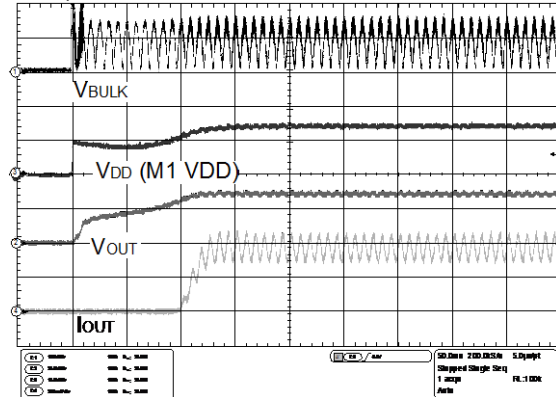

Stop waveform

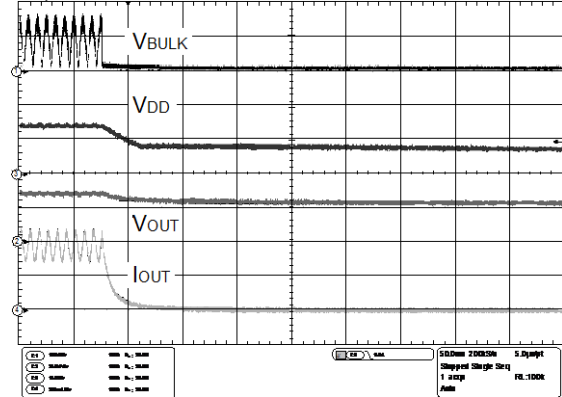

LED Open waveform

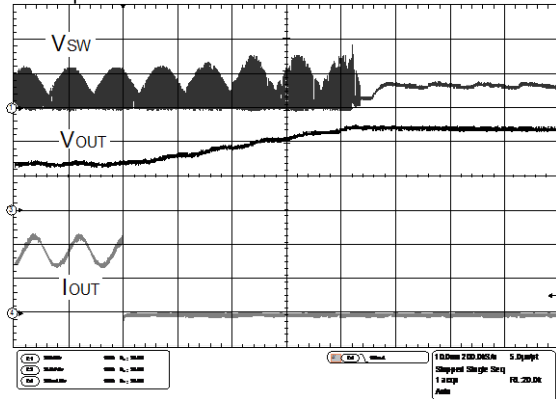

$V_{IN} = 220V_{RMS}$, 50 Hz, LED; 9 pcs in series

I/O waveform

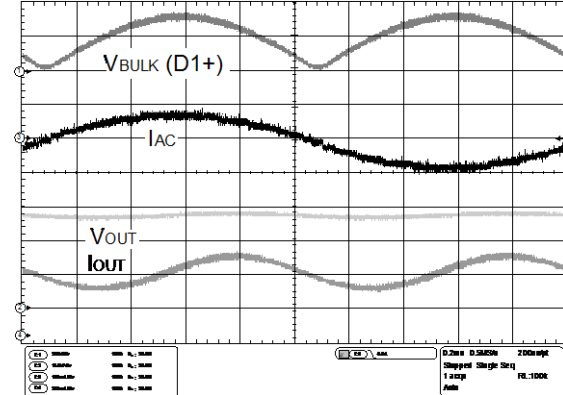

Switching waveform

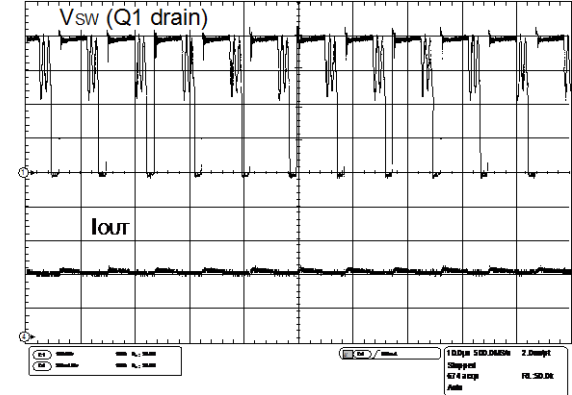

Startup waveform

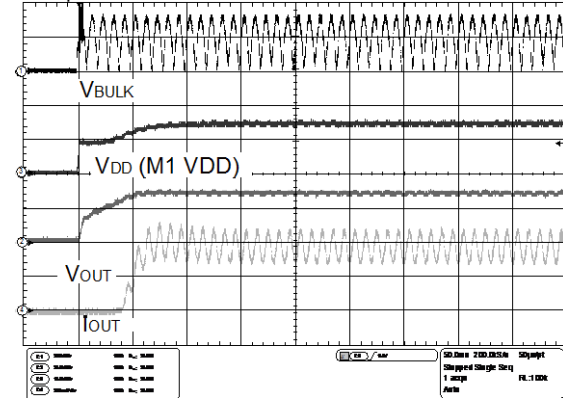

Stop waveform

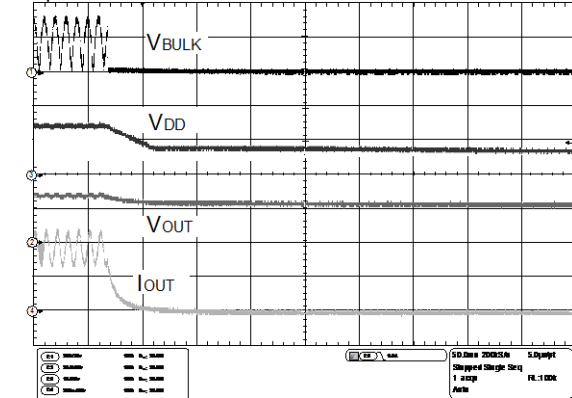

LED Open waveform

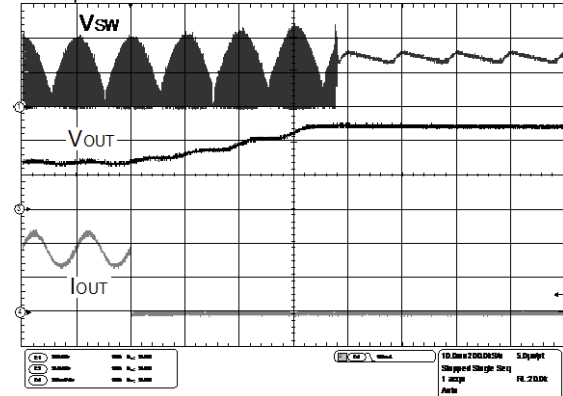

2. Non-isolation circuit

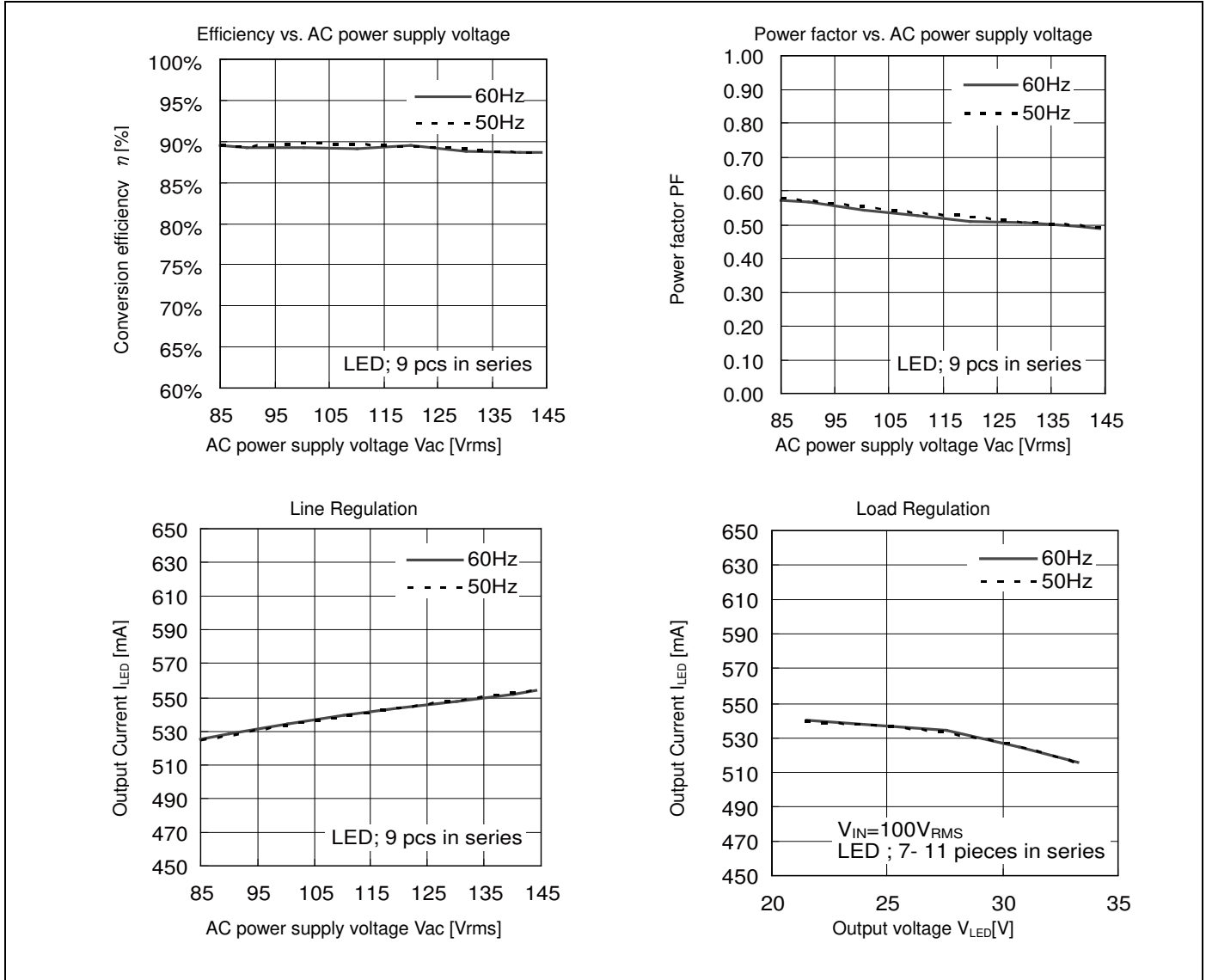

VIN=AC100V_{RMS}, fac=60 Hz, LED; 9 pieces in series

I/O waveform

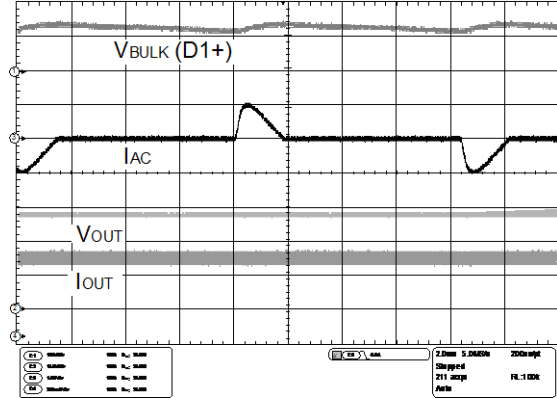

Switching waveform

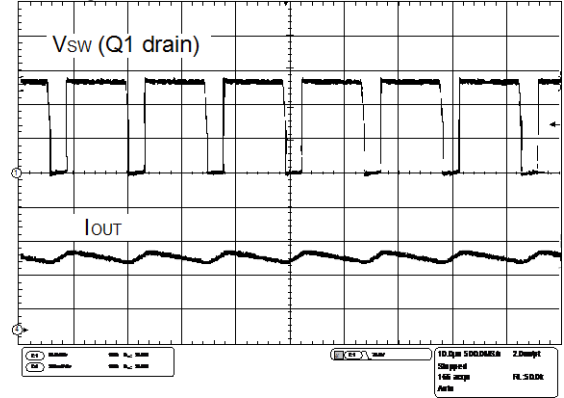

Startup waveform

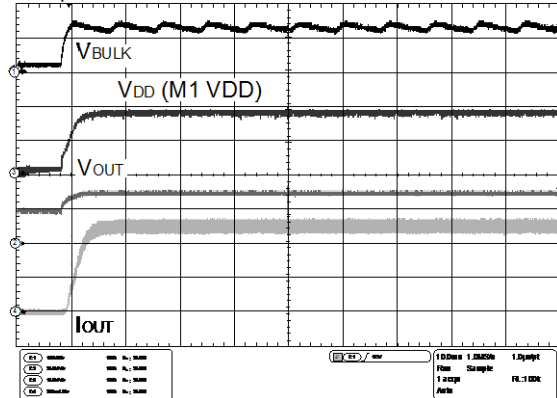

Stop waveform

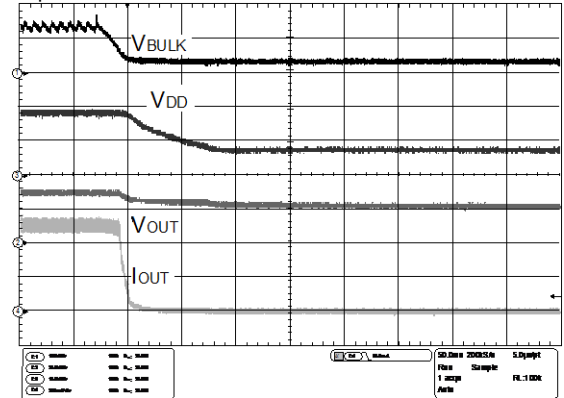

LED Open waveform

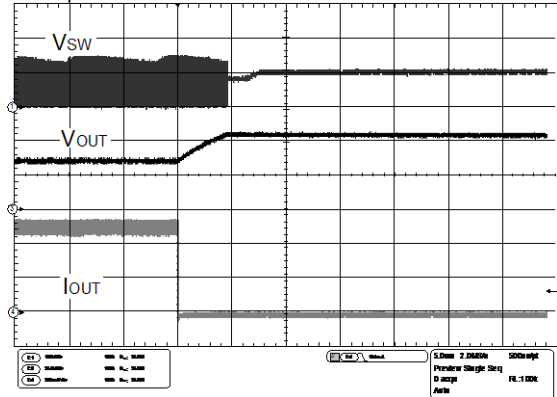

14. Usage Precaution

Do not configure the IC over the maximum ratings.

If the IC is used over the maximum ratings, the LSI may be permanently damaged.

It is preferable for the device to normally operate within the recommended usage conditions. Usage outside of these conditions can have an adverse effect on the reliability of the LSI.

Use the device within the recommended operating conditions.

The recommended values guarantee the normal LSI operation under the recommended operating conditions.

The electrical ratings are guaranteed when the device is used within the recommended operating conditions and under the conditions stated for each item.

Printed circuit board ground lines should be set up with consideration for common impedance.

Take appropriate measures against static electricity.

- Containers for semiconductor materials should have anti-static protection or be made of conductive material.
- After mounting, printed circuit boards should be stored and shipped in conductive bags or containers.
- Work platforms, tools, and instruments should be properly grounded.
- Working personnel should be grounded with resistance of 250 kΩ to 1 MΩ in serial between body and ground.

Do not apply negative voltages.

The use of negative voltages below - 0.3 V may make the parasitic transistor activated to the LSI, and can cause malfunctions.

15. Ordering Information

Part number	Package	Remarks
MB39C602PNF	8-pin plastic SOP (FPT-8P-M02)	

16. RoHS Compliance Information Of Lead (Pb) Free Version

The LSI products of Cypress with “E1” are compliant with RoHS Directive, and have observed the standard of lead, cadmium, mercury, Hexavalent chromium, polybrominated biphenyls (PBB), and polybrominated diphenyl ethers (PBDE). A product whose part number has trailing characters “E1” is RoHS compliant.

17. Marking Format (Lead Free Version)

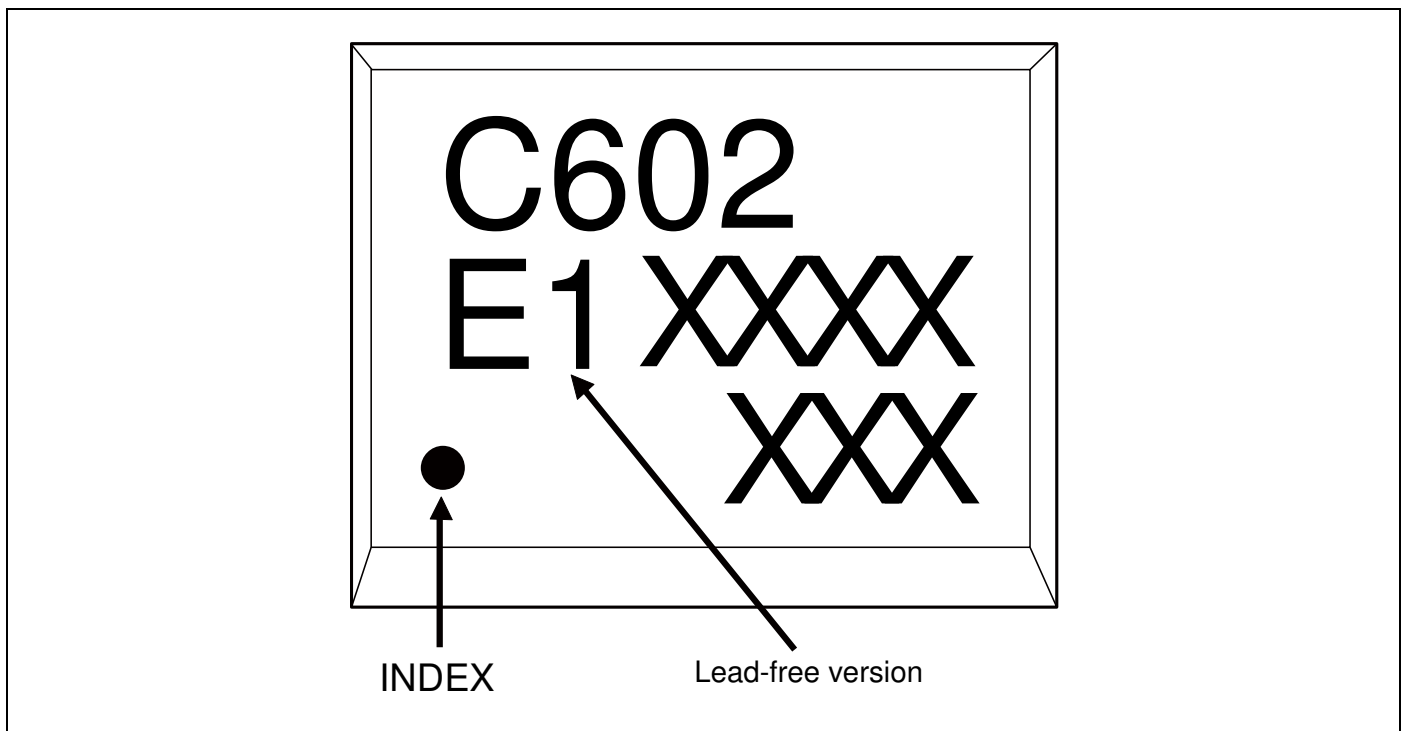

18. Labeling Sample (Lead free Version)

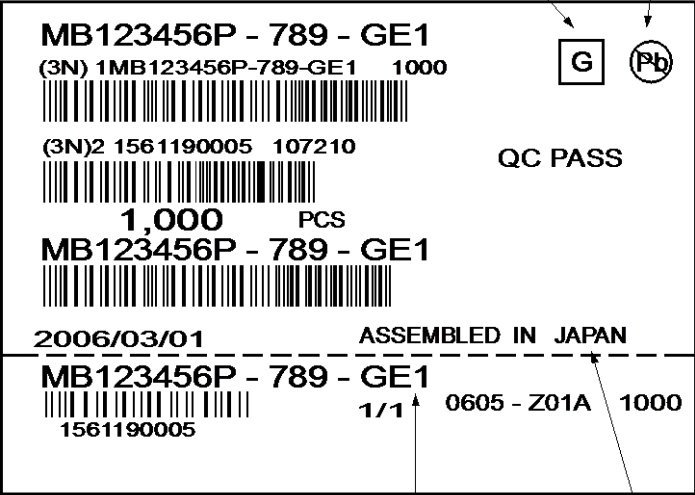

Lead-free mark
JEITA logo JEDEC logo

MB123456P - 789 - GE1
 (3N) 1MB123456P-789-GE1 1000
 (3N)2 1561190005 107210
 1,000 PCS
MB123456P - 789 - GE1
 2006/03/01 ASSEMBLED IN JAPAN
 MB123456P - 789 - GE1 1/1 0605 - Z01A 1000
 1561190005

QC PASS

The part number of a lead-free product has the trailing characters "E1".

"ASSEMBLED IN CHINA" is printed on the label of a product assembled in China.

19. MB39C602PNF Recommended Conditions of Moisture Sensitivity Level

[Cypress Recommended Mounting Conditions]

Recommended Reflow Condition

Item	Condition	
Mounting Method	IR (infrared reflow), warm air reflow	
Mounting times	2 times	
Storage period	Before opening	Please use it within two years after manufacture.
	From opening to the 2nd reflow	Less than 8 days
	When the storage period after opening was exceeded	Please process within 8 days after baking (125°C ±3°C, 24H+ 2H/-0H) . Baking can be performed up to two times.
Storage conditions	5°C to 30°C, 70% RH or less (the lowest possible humidity)	

[Mounting Conditions]

1. Reflow Profile

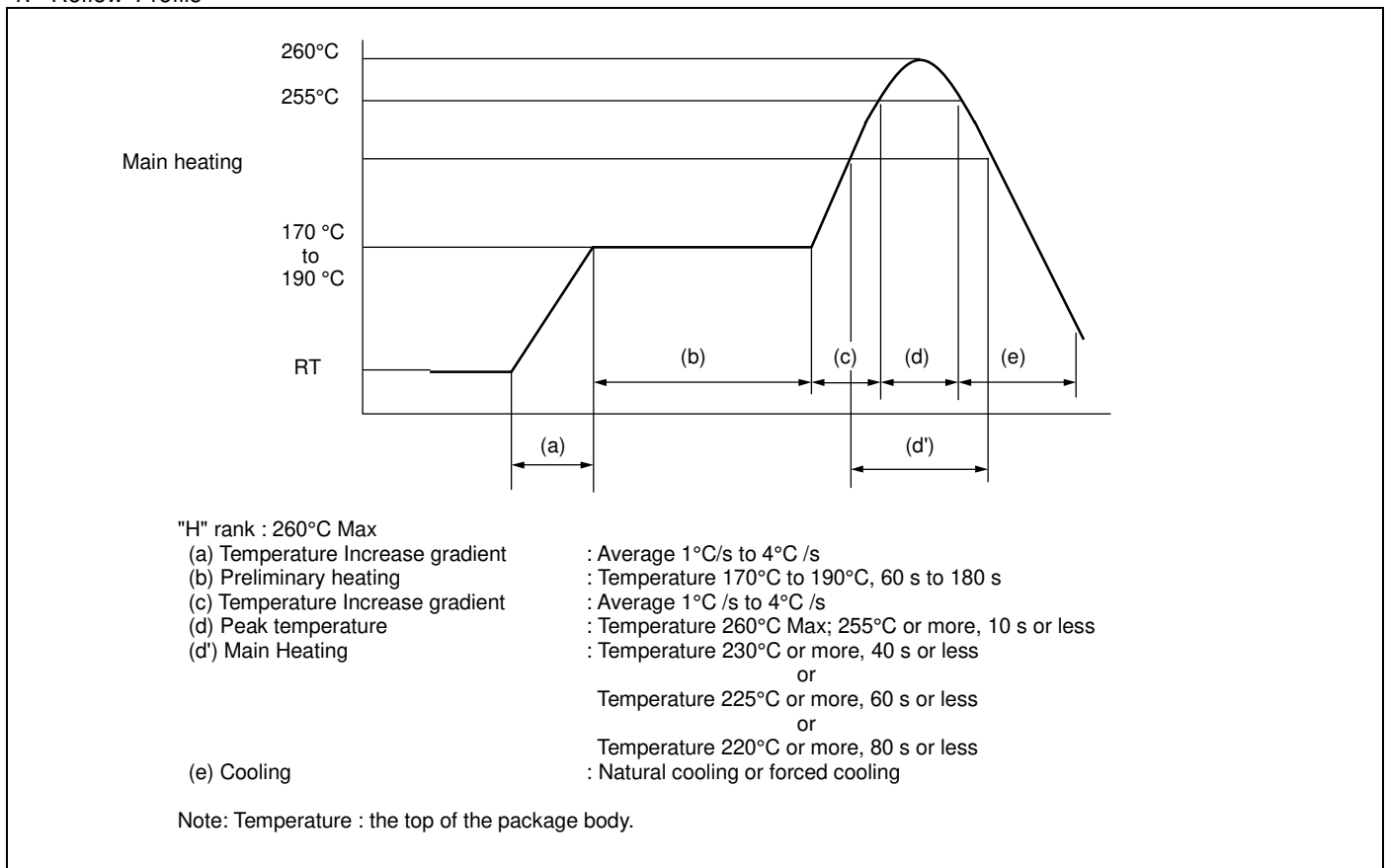

2. JEDEC Condition: Moisture Sensitivity Level 3 (IPC/JEDEC J-STD-020D)

3. Recommended manual soldering (partial heating method)

Item	Condition	
Storage period	Before opening	Within two years after manufacture
	Between opening and mounting	Within two years after manufacture (No need to control moisture during the storage period because of the partial heating method.)
Storage conditions	5°C to 30°C, 70% RH or less (the lowest possible humidity)	
Mounting conditions	Temperature at the tip of a soldering iron: 400°C Max Time: Five seconds or below per pin ^[1]	

[1]: Make sure that the tip of a soldering iron does not come in contact with the package body.

4. Recommended dip soldering

Item	Condition	
Mounting times	1 time	
Storage period	Before opening	Please use it within two years after manufacture.
	From opening and mounting	Less than 14 days
	When the storage period after opening was exceeded	Please process within 14 days after baking (125°C ±3°C, 24H+ 2H/-0H) . Baking can be performed up to two times.
Storage conditions	5°C to 30°C, 70% RH or less (the lowest possible humidity)	
Mounting condition	Temperature at soldering tub: 260°C Max Time: Five seconds or below	

20. Package Dimensions

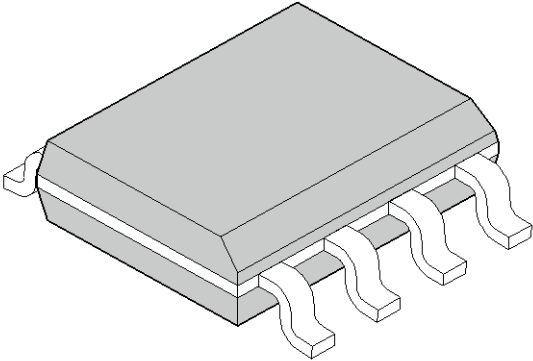
<p style="text-align: center;">8-pin plastic SOP</p>  <p style="text-align: center;">(FPT-8P-M02)</p>	Lead pitch	1.27 mm
	Package width × package length	3.9 mm × 5.05 mm
	Lead shape	Gullwing
	Sealing method	Plastic mold
	Mounting height	1.75 mm MAX
	Weight	0.06 g

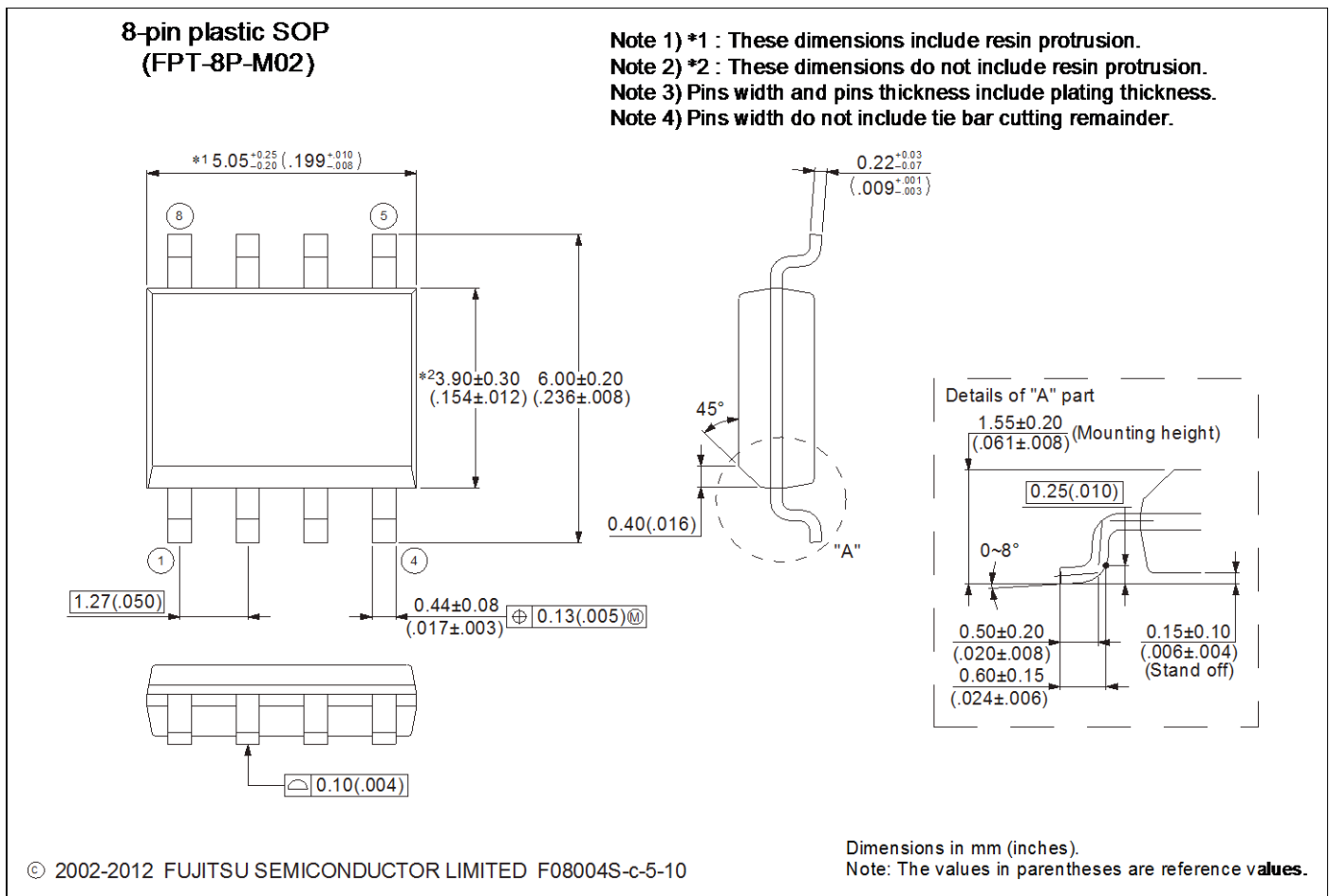

21. Major Changes

Spancion Publication Number: MB39C602_DS405-00010

Page	Section	Change Results
Revision 1.0 [December, 2012]		
-	-	Initial release
Revision 2.0 [July, 2013]		
5	RECOMMENDED OPERATING CONDITIONS	Revised the minimam value of symbol "ROTC". 25 → 10
8, 9	TYPICAL CHARACTERISTICS	Added "TYPICAL CHARACTERISTICS".
21 to 25	EXAMPLE APPLICATION CIRCUIT	Added "EXAMPLE APPLICATION CIRCUIT".
26 to 30	REFERENCE DATA	Added "REFERENCE DATA".
Revision 2.1 [January 31, 2014]		
-	-	Company name and layout design change

NOTE: Please see "Document History" about later revised information.

Document History

Document Title: MB39C602 High Power Factor LED Driver IC for LED Lighting

Document Number: 002-08397

Revision	ECN	Orig. of Change	Submission Date	Description of Change
**	-	TAOA	01/31/2014	Migrated to Cypress and assigned document number 002-08397. No change to document contents or format.
*A	5211073	TAOA	04/13/2016	Updated to Cypress format.

Sales, Solutions, and Legal Information

Worldwide Sales and Design Support

Cypress maintains a worldwide network of offices, solution centers, manufacturer's representatives, and distributors. To find the office closest to you, visit us at [Cypress Locations](#).

Products

ARM® Cortex® Microcontrollers	cypress.com/arm
Automotive	cypress.com/automotive
Clocks & Buffers	cypress.com/clocks
Interface	cypress.com/interface
Lighting & Power Control	cypress.com/powerpsoc
Memory	cypress.com/memory
PSoC	cypress.com/psoc
Touch Sensing	cypress.com/touch
USB Controllers	cypress.com/usb
Wireless/RF	cypress.com/wireless

PSoC® Solutions

psoc.cypress.com/solutions

PSoC 1 | PSoC 3 | PSoC 4 | PSoC 5LP

Cypress Developer Community

[Community](#) | [Forums](#) | [Blogs](#) | [Video](#) | [Training](#)

Technical Support

cypress.com/go/support

© Cypress Semiconductor Corporation, 2012-2016. This document is the property of Cypress Semiconductor Corporation and its subsidiaries, including Spansion LLC ("Cypress"). This document, including any software or firmware included or referenced in this document ("Software"), is owned by Cypress under the intellectual property laws and treaties of the United States and other countries worldwide. Cypress reserves all rights under such laws and treaties and does not, except as specifically stated in this paragraph, grant any license under its patents, copyrights, trademarks, or other intellectual property rights. If the Software is not accompanied by a license agreement and you do not otherwise have a written agreement with Cypress governing the use of the Software, then Cypress hereby grants you under its copyright rights in the Software, a personal, non-exclusive, nontransferable license (without the right to sublicense) (a) for Software provided in source code form, to modify and reproduce the Software solely for use with Cypress hardware products, only internally within your organization, and (b) to distribute the Software in binary code form externally to end users (either directly or indirectly through resellers and distributors), solely for use on Cypress hardware product units. Cypress also grants you a personal, non-exclusive, nontransferable, license (without the right to sublicense) under those claims of Cypress's patents that are infringed by the Software (as provided by Cypress, unmodified) to make, use, distribute, and import the Software solely to the minimum extent that is necessary for you to exercise your rights under the copyright license granted in the previous sentence. Any other use, reproduction, modification, translation, or compilation of the Software is prohibited.

CYPRESS MAKES NO WARRANTY OF ANY KIND, EXPRESS OR IMPLIED, WITH REGARD TO THIS DOCUMENT OR ANY SOFTWARE, INCLUDING, BUT NOT LIMITED TO, THE IMPLIED WARRANTIES OF MERCHANTABILITY AND FITNESS FOR A PARTICULAR PURPOSE. Cypress reserves the right to make changes to this document without further notice. Cypress does not assume any liability arising out of the application or use of any product or circuit described in this document. Any information provided in this document, including any sample design information or programming code, is provided only for reference purposes. It is the responsibility of the user of this document to properly design, program, and test the functionality and safety of any application made of this information and any resulting product. Cypress products are not designed, intended, or authorized for use as critical components in systems designed or intended for the operation of weapons, weapons systems, nuclear installations, life-support devices or systems, other medical devices or systems (including resuscitation equipment and surgical implants), pollution control or hazardous substances management, or other uses where the failure of the device or system could cause personal injury, death, or property damage ("Unintended Uses"). A critical component is any component of a device or system whose failure to perform can be reasonably expected to cause the failure of the device or system, or to affect its safety or effectiveness. Cypress is not liable, in whole or in part, and Company shall and hereby does release Cypress from any claim, damage, or other liability arising from or related to all Unintended Uses of Cypress products. Company shall indemnify and hold Cypress harmless from and against all claims, costs, damages, and other liabilities, including claims for personal injury or death, arising from or related to any Unintended Uses of Cypress products.

Cypress, the Cypress logo, Spansion, the Spansion logo, and combinations thereof, PSoC, CapSense, EZ-USB, F-RAM, and Traveo are trademarks or registered trademarks of Cypress in the United States and other countries. For a more complete list of Cypress trademarks, visit cypress.com. Other names and brands may be claimed as property of their respective owners.