

THIS DRAWING IS UNPUBLISHED. RELEASED FOR PUBLICATION  
 © COPYRIGHT BY TYCO ELECTRONICS CORPORATION. ALL INTERNATIONAL RIGHTS RESERVED.

LOC	DIST	REVISIONS			
P	LTR	DESCRIPTION	DATE	DWN	APVD
G	14	A2	REVISED PER ECR 08-017416	16JUL08	JR TM

**AMP**  
**WIRE SIZE**  
 12-10 AWG  
 SOLID OR STRANDED

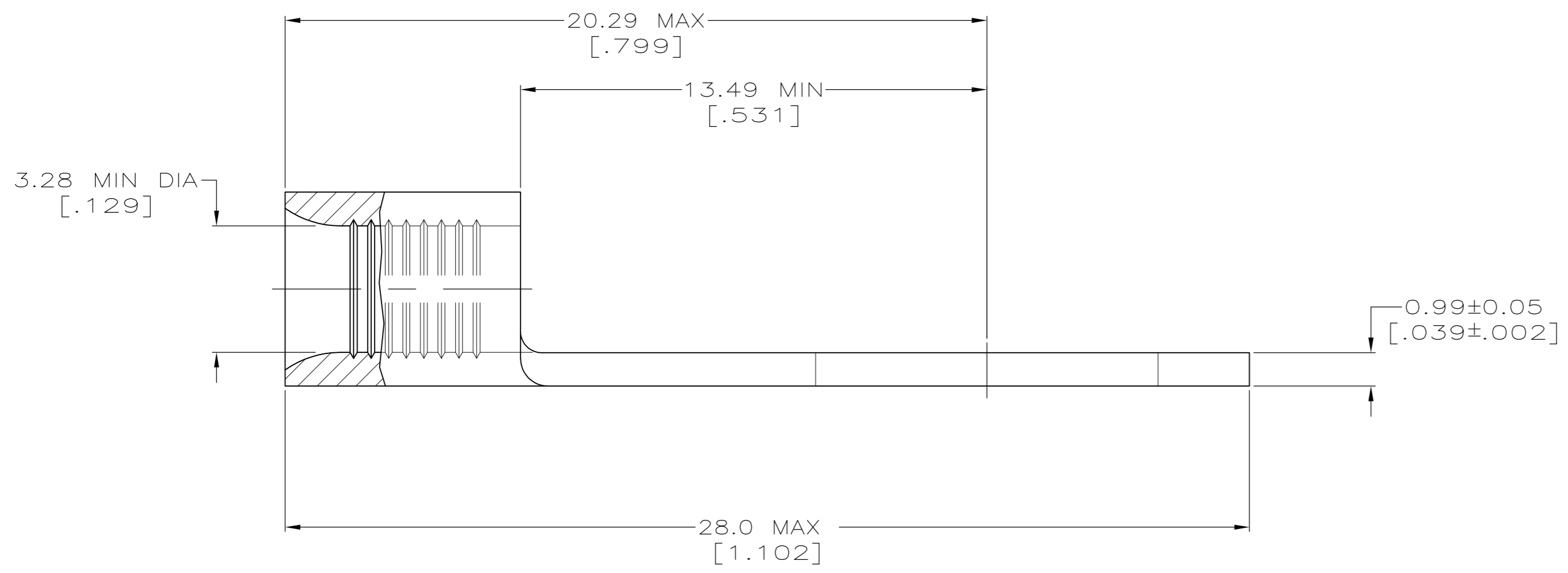
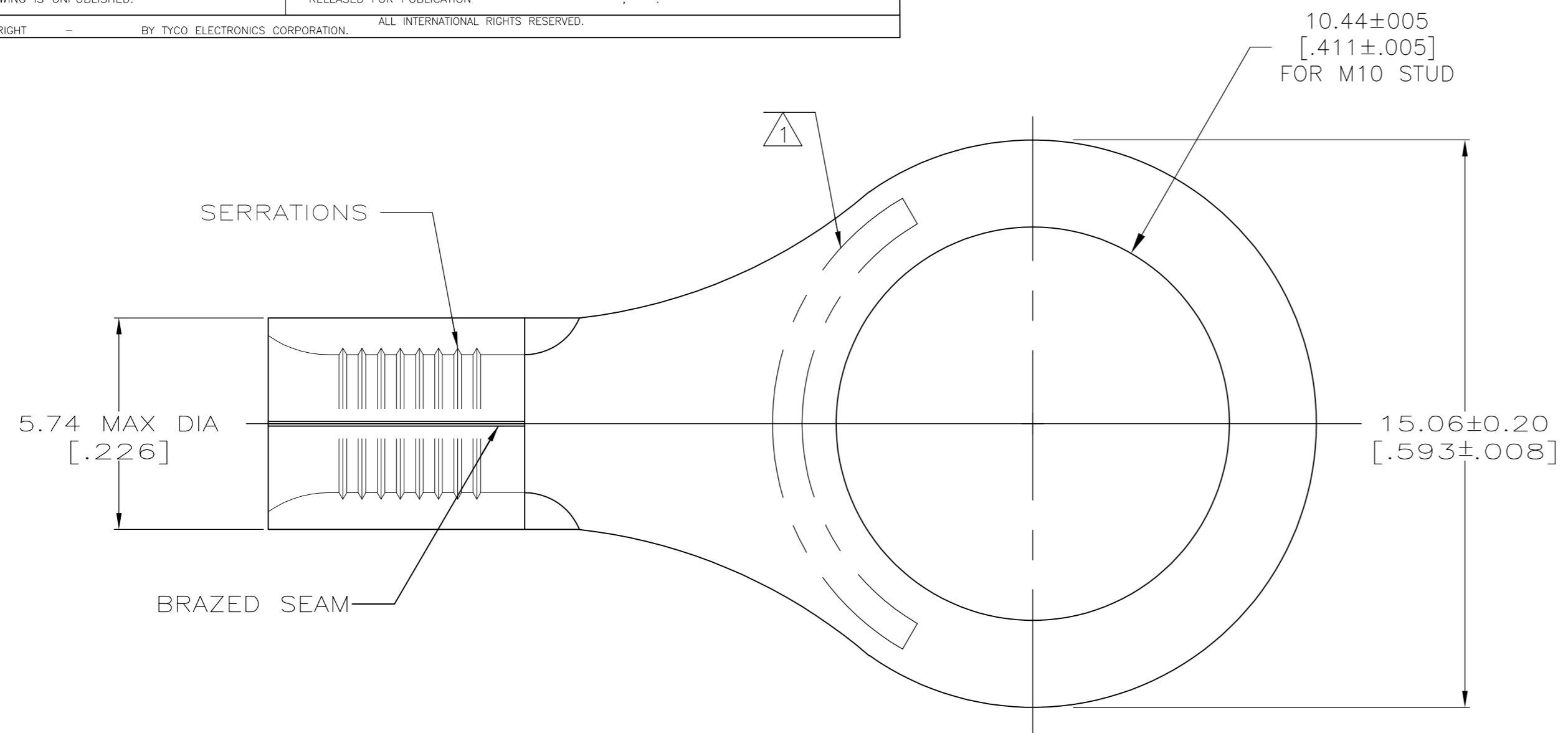

- 1 STAMP AMP 12-10\* LOCATED APPROX AS SHOWN
- 2 COPPER PER ASTM B-152, ANNEALED
- 3 0.00254 [.000100] MIN TIN PER ASTM B-545
- 4 MAX RECOMMENDED OPERATING TEMP 170°C
- 5 WIRE CROSS SECTIONAL AREA RANGE.  
2.62-6.64mm<sup>2</sup> [5,180-13,100] CIR MILS

1000	TAPE MOUNTED	2-160121-1
500	LOOSE PIECE	160121
QTY	PACKAGE TYPE	PART NO.

THIS DRAWING IS A CONTROLLED DOCUMENT.		DWN jr ruth 05JUN08	Tyco Electronics Corporation Harrisburg, PA 17105-3608	
DIMENSIONS: MM [ INCHES ]		CHK T MICHELUTTI 05JUN08	NAME TERMINAL, RING TONGUE, SOLISTRAND	
TOLERANCES UNLESS OTHERWISE SPECIFIED:		APVD T MICHELUTTI 05JUN08	SIZE A2	CAGE CODE 00779
0 PLC ± -		PRODUCT SPEC	DRAWING NO C=160121	RESTRICTED TO
1 PLC ± -		APPLICATION SPEC	SCALE 8:1	SHEET 1 of 1
2 PLC ± 0.2 [.008]		WEIGHT	REV A2	
3 PLC ± -		CUSTOMER DRAWING		
4 PLC ± -				
ANGLES ± -				
FINISH				