

300mA, Low Dropout, Low Noise Ultra-Fast Without Bypass Capacitor CMOS LDO Regulator

General Description

The RT9013B is a high-performance, 300mA LDO regulator, offering extremely high PSRR and ultra-low dropout. The RT9013B is ideal for portable RF and wireless applications with demanding performance and space requirements.

The RT9013B provides quiescent current to be as low as 25uA to extend the battery life. The RT9013B also works with low-ESR ceramic capacitors, reducing the amount of board space necessary for power applications, especially for hand-held wireless devices.

The RT9013B consumes typical 0.7uA in shutdown mode and has fast turn-on time to be less than 40us. The other features include ultra-low dropout voltage, high output accuracy, current limiting protection, and high ripple rejection ratio. The RT9013B is available in the SC-70-5 and WDFN-6L 1.6x1.6 packages.

Ordering Information

| | |
|--------------|------------------------------------|
| RT9013B-□□□□ | |
| □ | Package Type |
| U5 | : SC-70-5 |
| QWC | : WDFN-6L 1.6x1.6 (W-Type) |
| □ | Lead Plating System |
| P | : Pb Free |
| G | : Green (Halogen Free and Pb Free) |
| □ | Fixed Output Voltage |
| 12 | : 1.2V |
| 13 | : 1.3V |
| : | |
| 34 | : 3.4V |
| 35 | : 3.5V |
| 1B | : 1.25V |
| 1H | : 1.85V |
| 2H | : 2.85V |

Note :

Richtek products are :

- ▶ RoHS compliant and compatible with the current requirements of IPC/JEDEC J-STD-020.
- ▶ Suitable for use in SnPb or Pb-free soldering processes.

Features

- Wide Operating Voltage Range : 2.2V to 5.5V
- Low Dropout : 150mV at 300mA
- Ultra-Low-Noise for RF Application
- Ultra-Fast in Line/Load Transient Response
- Current Limiting Protection
- Thermal Shutdown Protection
- High Power Supply Rejection Ratio
- Only 1uF Output Capacitor Required for Stability
- TTL-Logic-Controlled Shutdown Input
- RoHS Compliant and 100% Lead (Pb)-Free

Applications

- CDMA/GSM Cellular Handsets
- Portable Information Appliances
- Laptop, Palmtops, Notebook Computers
- Hand-Held Instruments
- Mini PCI & PCI-Express Cards
- PCMCIA & New Cards

Marking Information

For marking information, contact our sales representative directly or through a Richtek distributor located in your area.

Pin Configurations

(TOP VIEW)

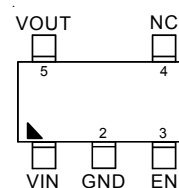

SC-70-5

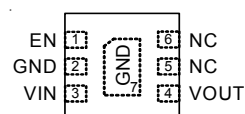

WDFN-6L 1.6x1.6

Typical Application Circuit

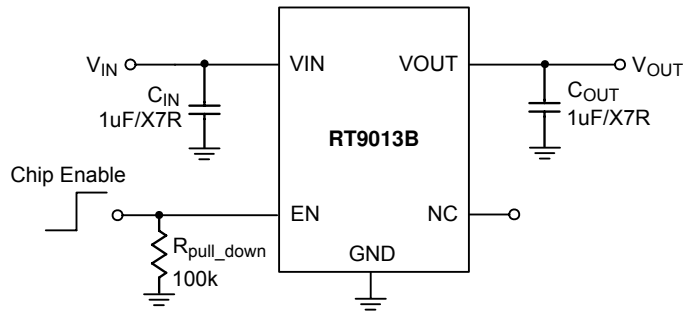

Functional Pin Description

| Pin No. | | Pin Name | Pin Function |
|---------|-----------------------|----------|--|
| SC-70-5 | WDFN-6L 1.6x1.6 | | |
| 1 | 3 | VIN | Supply Input. |
| 2 | 2, 7 (Exposed Pad) | GND | Common Ground. The exposed pad must be soldered to a large PCB and connected to GND for maximum power dissipation. |
| 3 | 1 | EN | Chip Enable (Active High). It is recommended to add a 100kΩ resistor between the EN and GND. |
| 4 | 5, 6 | NC | No Internal Connection. |
| 5 | 4 | VOUT | Regulator Output. |

Function Block Diagram

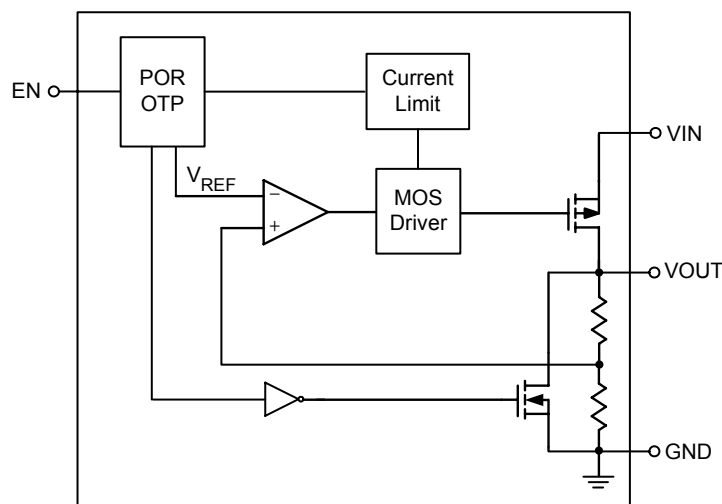

Absolute Maximum Ratings (Note 1)

- Supply Input Voltage ----- 6V
- EN Input Voltage ----- 6V
- Power Dissipation, P_D @ $T_A = 25^\circ\text{C}$
 - SC-70-5 ----- 0.3W
 - WDFN-6L 1.6x1.6 ----- 0.606W
- Package Thermal Resistance (Note 2)
 - SC-70-5, θ_{JA} ----- 333°C/W
 - WDFN-6L 1.6x1.6, θ_{JA} ----- 165°C/W
- Lead Temperature (Soldering, 10 sec.) ----- 260°C
- Junction Temperature ----- 150°C
- Storage Temperature Range ----- -65°C to 150°C
- ESD Susceptibility (Note 3)
 - HBM ----- 2kV
 - MM ----- 200V

Recommended Operating Conditions (Note 4)

- Supply Input Voltage ----- 2.2V to 5.5V
- Junction Temperature Range ----- -40°C to 125°C
- Ambient Temperature Range ----- -40°C to 85°C

Electrical Characteristics

($V_{IN} = V_{OUT} + 0.5V$, $V_{EN} = V_{IN}$, $C_{IN} = C_{OUT} = 1\mu\text{F}/X7R$ (Ceramic), $T_A = 25^\circ\text{C}$, unless otherwise specified)

| Parameter | Symbol | Test Conditions | Min | Typ | Max | Unit |
|--|--------------------|---|-----|------|-----|----------------------------|
| Input Voltage Range | V_{IN} | | 2.2 | -- | 5.5 | V |
| Output Noise Voltage | V_{ON} | $V_{OUT} = 1.5V$ | -- | 30 | -- | μV_{RMS} |
| Output Voltage Accuracy (Fixed Output Voltage) | ΔV_{OUT} | $I_{OUT} = 10\text{mA}$ | -2 | 0 | +2 | % |
| Quiescent Current (Note 5) | I_Q | $V_{EN} = 5V$, $I_{OUT} = 0\text{mA}$ | -- | 25 | 50 | μA |
| Shutdown Current | I_{SHDN} | $V_{EN} = 0V$ | -- | 0.7 | 1.5 | μA |
| Current Limit | I_{LIM} | $R_{LOAD} = 0\Omega$, $2.2V \leq V_{IN} < 5.5V$ | 300 | 400 | 600 | mA |
| Dropout Voltage (Note 6) | V_{DROP} | $I_{OUT} = 300\text{mA}$ | -- | 125 | 240 | mV |
| Load Regulation (Note 7) (Fixed Output Voltage) | ΔV_{LOAD} | $1\text{mA} < I_{OUT} < 300\text{mA}$ $2.2V \leq V_{IN} < 2.7V$ | -- | -- | 0.6 | % |
| | | $1\text{mA} < I_{OUT} < 300\text{mA}$ $2.7V \leq V_{IN} \leq 5.5V$ | -- | -- | 1 | |
| EN Threshold | Logic-Low Voltage | V_{IL} | 0 | -- | 0.6 | V |
| | Logic-High Voltage | V_{IH} | 1.6 | -- | 5.5 | |
| Enable Pin Current | I_{EN} | | -- | 0.1 | 1 | μA |
| Power Supply Rejection Rate | PSRR | $I_{OUT} = 100\text{mA}$, $f = 10\text{kHz}$ | -- | -50 | -- | dB |
| Line Regulation | ΔV_{LINE} | $V_{IN} = (V_{OUT} + 0.5)$ to $5.5V$, $I_{OUT} = 1\text{mA}$ | -- | 0.01 | 0.2 | %/V |
| Thermal Shutdown Temperature | T_{SD} | | -- | 170 | -- | °C |
| Thermal Shutdown Hysteresis | ΔT_{SD} | | -- | 30 | -- | |

- Note 1.** Stresses listed as the above “Absolute Maximum Ratings” may cause permanent damage to the device. These are for stress ratings. Functional operation of the device at these or any other conditions beyond those indicated in the operational sections of the specifications is not implied. Exposure to absolute maximum rating conditions for extended periods may remain possibility to affect device reliability.
- Note 2.** θ_{JA} is measured in the natural convection at $T_A = 25^\circ\text{C}$ on a low effective thermal conductivity single layer test board of JEDEC 51-3 thermal measurement standard.
- Note 3.** Devices are ESD sensitive. Handling precaution is recommended.
- Note 4.** The device is not guaranteed to function outside its operating conditions.
- Note 5.** Quiescent, or ground current, is the difference between input and output currents. It is defined by $I_Q = I_{IN} - I_{OUT}$ under no load condition ($I_{OUT} = 0\text{mA}$). The total current drawn from the supply is the sum of the load current plus the ground pin current.
- Note 6.** The dropout voltage is defined as $V_{IN} - V_{OUT}$, which is measured when V_{OUT} is $V_{OUT(NORMAL)} - 100\text{mV}$.
- Note 7.** Regulation is measured at constant junction temperature by using a 2ms current pulse. Devices are tested for load regulation in the load range from 10mA to 300mA.

Typical Operating Characteristics

($C_{IN} = C_{OUT} = 1\mu/X7R$, unless otherwise specified)

Output Voltage vs. Temperature

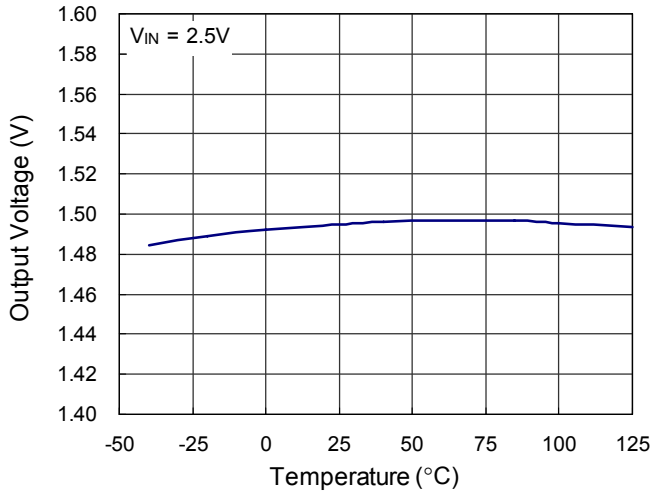

Quiescent Current vs. Temperature

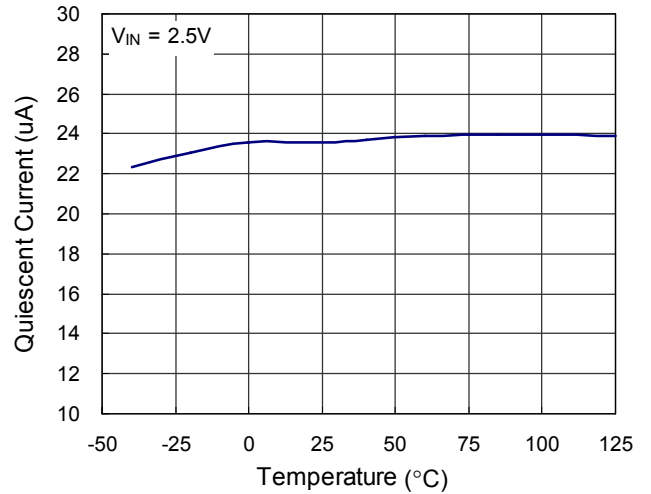

Dropout Voltage vs. Load Current

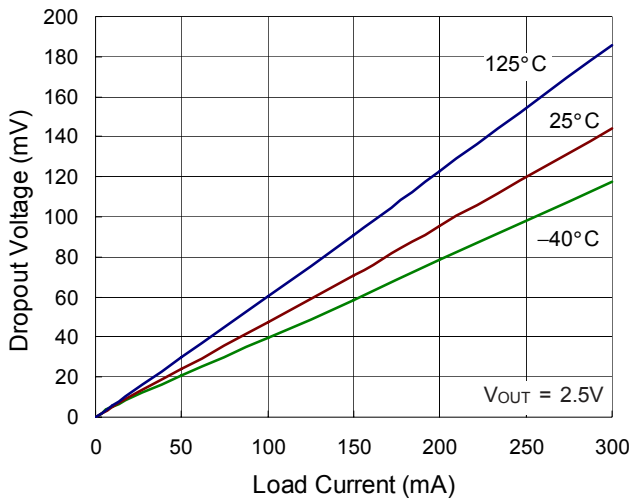

EN Pin Shutdown Response

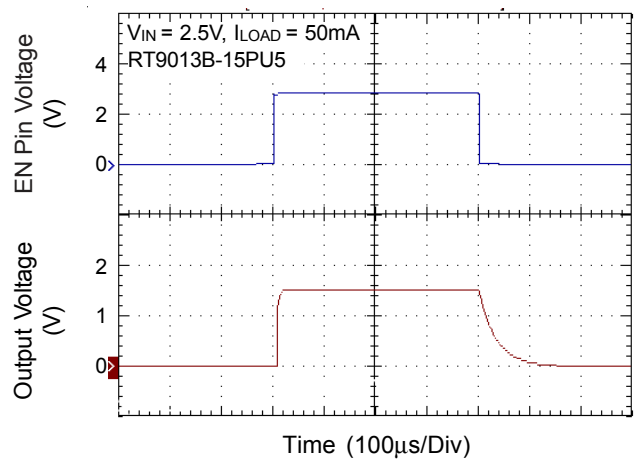

Start Up

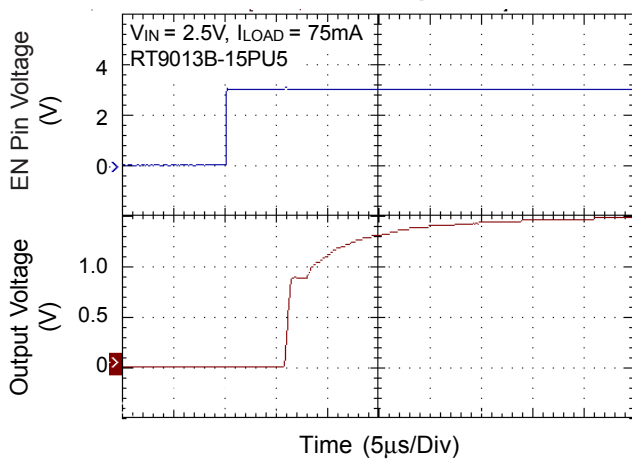

Line Transient Response

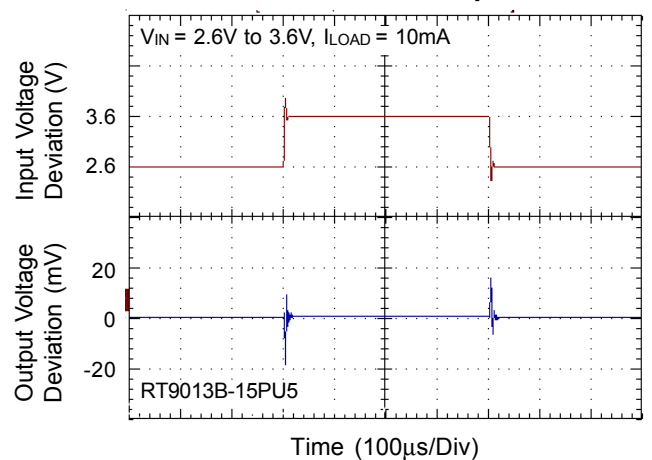

Line Transient Response

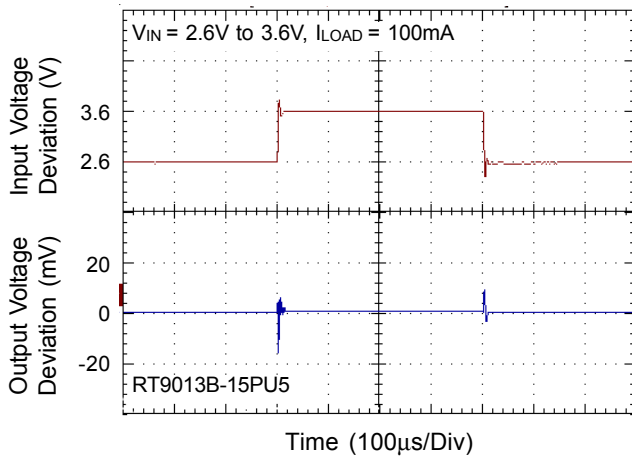

Noise

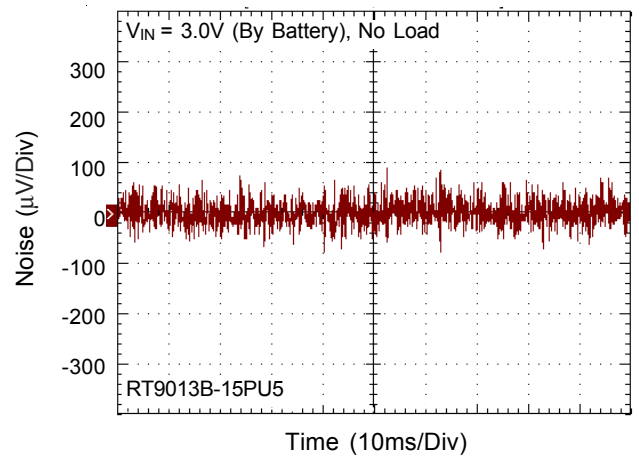

Noise

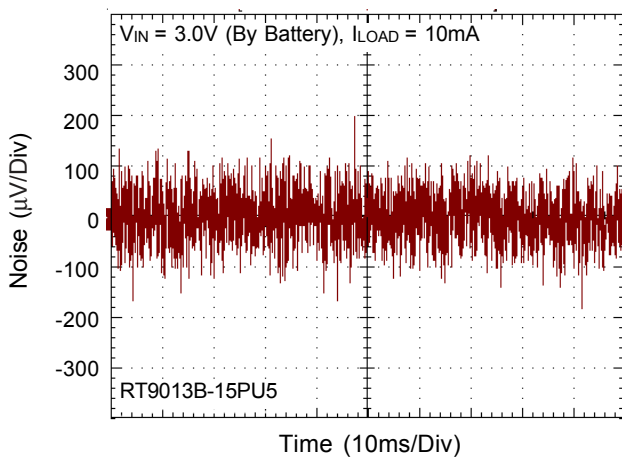

Load Transient Response

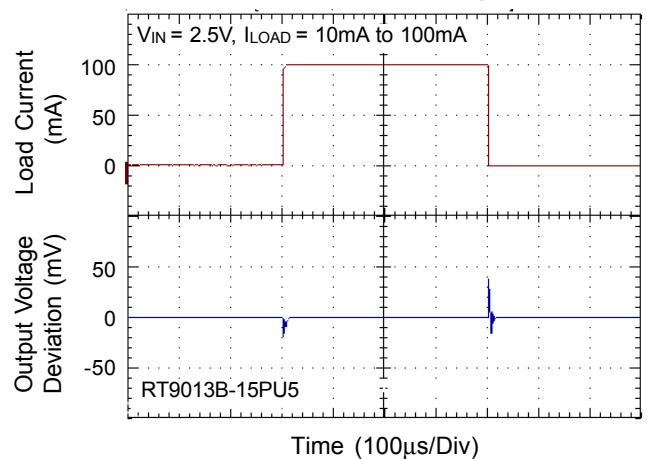

PSRR

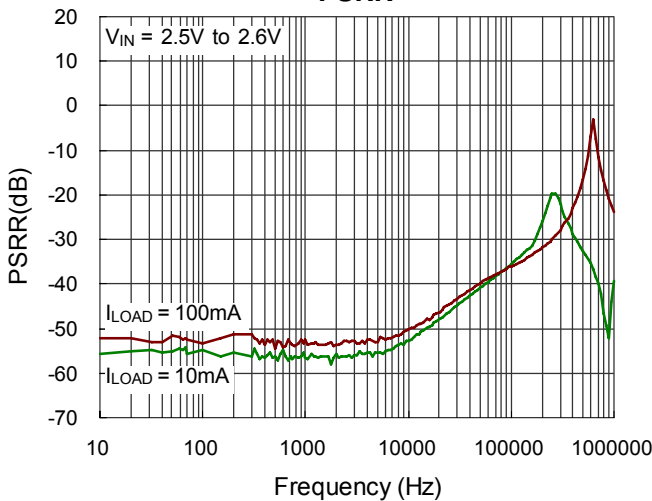

Applications Information

Like any low-dropout regulator, the external capacitors used with the RT9013B must be carefully selected for regulator stability and performance. Using a capacitor whose value is $> 1\mu\text{F} / X7R$ on the RT9013B input and the amount of capacitance can be increased without limit. The input capacitor must be located at a distance of not more than 0.5 inch from the input pin of the IC and returned to a clean analog ground. Any good quality ceramic can be used for this capacitor. The capacitor with larger value and lower ESR (equivalent series resistance) provides better PSRR and line-transient response.

The output capacitor must meet both requirements for minimum amount of capacitance and ESR in all LDOs application. The RT9013B is designed specifically to work with low ESR ceramic output capacitor in space-saving and performance consideration. Using a ceramic capacitor whose value is at least $1\mu\text{F}$ with ESR is $> 20\text{m}\Omega$ on the RT9013B output ensures stability. The RT9013B still works well with output capacitor of other types due to the wide stable ESR range. Figure 1. shows the curves of allowable ESR range as a function of load current for various output capacitor values. Output capacitor of larger capacitance can reduce noise and improve load transient response, stability, and PSRR. The output capacitor should be located not more than 0.5 inch from the VOUT pin of the RT9013B and returned to a clean analog ground.

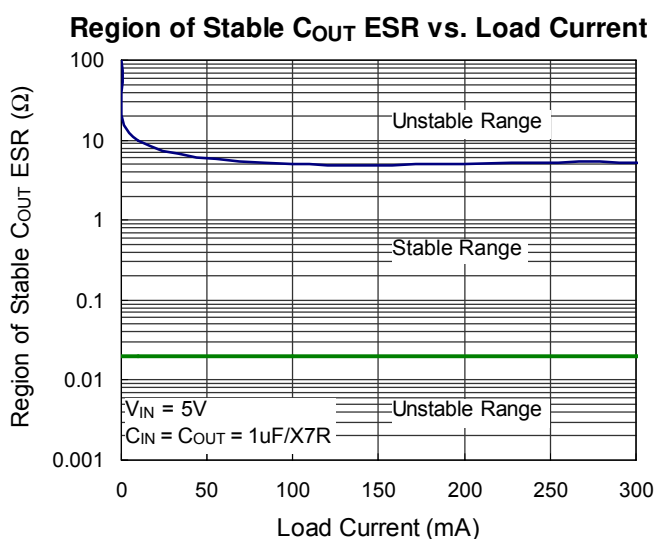

Figure 1

Enable

The RT9013B goes into sleep mode when the EN pin is in a logic low condition. During this condition, the RT9013B has an EN pin to turn on or turn off the regulator. When the EN pin is logic high the regulator will be turned on. The supply current to 0.7uA typical. The EN pin may be directly tied to V_{IN} to keep the part on. The Enable input is CMOS logic and cannot be left floating.

PSRR

The power supply rejection ratio (PSRR) is defined as the gain from the input to output divided by the gain from the supply to the output. The PSRR is found to be

$$\text{PSRR} = 20 \times \log \left(\frac{\Delta \text{Gain Error}}{\Delta \text{Supply}} \right)$$

Note that in heavy load measuring, Δsupply will cause $\Delta \text{temperature}$. And $\Delta \text{temperature}$ will cause Δoutput voltage. So the temperature effect is include in heavy load PSRR measuring.

Current Limit

The RT9013B contains an independent current limiter, which monitors and controls the pass transistor's gate voltage, limiting the output current to 0.4A (typ.). The output can be shorted to ground indefinitely without damaging the part.

Thermal Considerations

Thermal protection limits power dissipation in the RT9013B. When the operation junction temperature exceeds 170°C, the OTP circuit starts the thermal shutdown function and turns the pass element off. The pass element will be turned on again after the junction temperature cools by 30°C.

For continuous operation, do not exceed absolute maximum operation junction temperature 125°C. The power dissipation definition in the device is calculated as follows :

$$P_D = (V_{IN} - V_{OUT}) \times I_{OUT} + V_{IN} \times I_Q$$

The maximum power dissipation depends on the thermal resistance of IC package, PCB layout, the rate of surroundings airflow and temperature difference between

junction to ambient. The maximum power dissipation can be calculated by following formula :

$$P_{D(MAX)} = (T_{J(MAX)} - T_A) / \theta_{JA}$$

Where $T_{J(MAX)}$ is the maximum operation junction temperature, T_A is the ambient temperature and the θ_{JA} is the junction to ambient thermal resistance.

For recommended operating conditions specification of the RT9013B, where $T_{J(MAX)}$ is the maximum junction temperature of the die (125°C) and T_A is the operated ambient temperature. The junction to ambient thermal resistance for SC-70-5 package is 333°C/W and WDFN-6L 1.6x1.6 package is 165°C/W on the standard JEDEC 51-3 single-layer thermal test board. The maximum power dissipation at $T_A = 25^\circ\text{C}$ can be calculated by following formula :

$$P_{D(MAX)} = (125^\circ\text{C} - 25^\circ\text{C}) / (333^\circ\text{C/W}) = 0.3\text{W for SC-70-5 packages}$$

$$P_{D(MAX)} = (125^\circ\text{C} - 25^\circ\text{C}) / (165^\circ\text{C/W}) = 0.606\text{W for WDFN-6L 1.6x1.6 packages}$$

The maximum power dissipation depends on operating ambient temperature for fixed $T_{J(MAX)}$ and thermal resistance θ_{JA} . For RT9013B packages, the Figure 2 of derating curves allows the designer to see the effect of rising ambient temperature on the maximum power allowed.

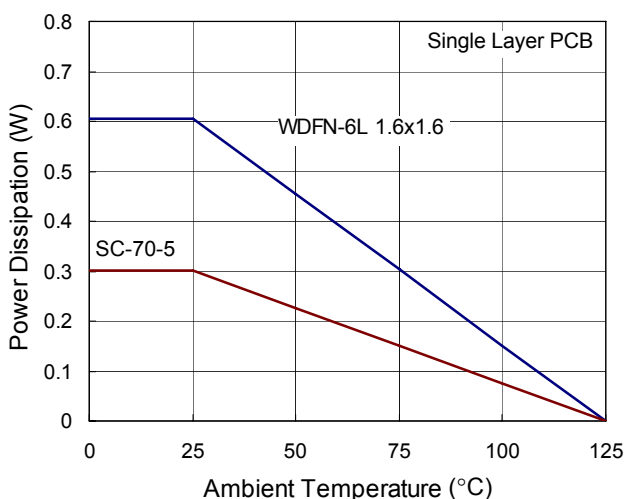
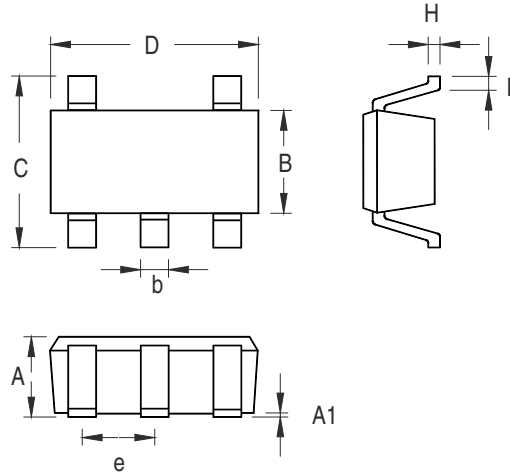

Figure 2. Derating Curves for RT9013B Packages

Outline Dimension



| Symbol | Dimensions In Millimeters | | Dimensions In Inches | |
|--------|---------------------------|-------|----------------------|-------|
| | Min | Max | Min | Max |
| A | 0.800 | 1.100 | 0.031 | 0.044 |
| A1 | 0.000 | 0.100 | 0.000 | 0.004 |
| B | 1.150 | 1.350 | 0.045 | 0.054 |
| b | 0.150 | 0.400 | 0.006 | 0.016 |
| C | 1.800 | 2.450 | 0.071 | 0.096 |
| D | 1.800 | 2.250 | 0.071 | 0.089 |
| e | 0.650 | | 0.026 | |
| H | 0.080 | 0.260 | 0.003 | 0.010 |
| L | 0.210 | 0.460 | 0.008 | 0.018 |

SC-70-5 Surface Mount Package

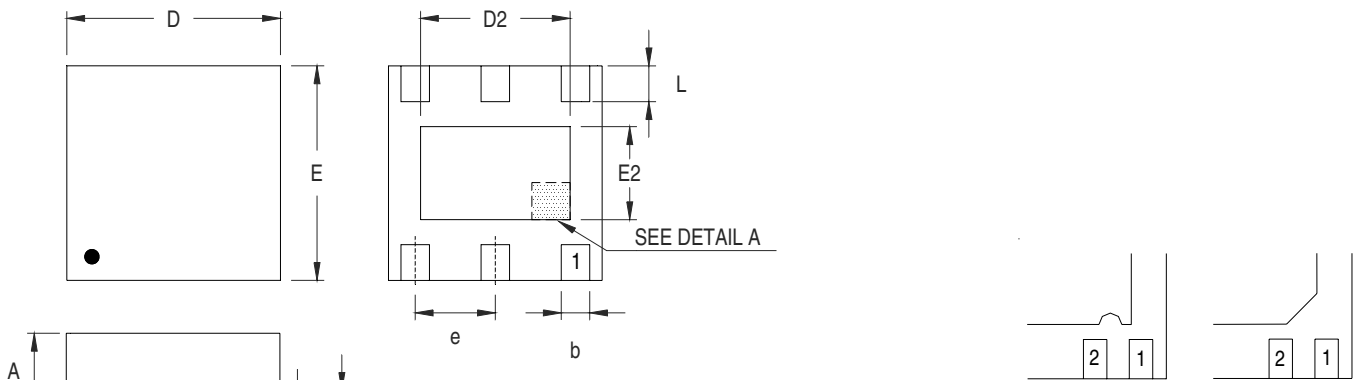

DETAIL A

Pin #1 ID and Tie Bar Mark Options

Note : The configuration of the Pin #1 identifier is optional, but must be located within the zone indicated.

| Symbol | Dimensions In Millimeters | | Dimensions In Inches | |
|--------|---------------------------|-------|----------------------|-------|
| | Min | Max | Min | Max |
| A | 0.700 | 0.800 | 0.028 | 0.031 |
| A1 | 0.000 | 0.050 | 0.000 | 0.002 |
| A3 | 0.175 | 0.250 | 0.007 | 0.010 |
| b | 0.200 | 0.300 | 0.008 | 0.012 |
| D | 1.550 | 1.650 | 0.061 | 0.065 |
| D2 | 0.950 | 1.050 | 0.037 | 0.041 |
| E | 1.550 | 1.650 | 0.061 | 0.065 |
| E2 | 0.550 | 0.650 | 0.022 | 0.026 |
| e | 0.500 | | 0.020 | |
| L | 0.190 | 0.290 | 0.007 | 0.011 |

W-Type 6L DFN 1.6x1.6 Package

Richtek Technology Corporation

Headquarter
 5F, No. 20, Taiyuen Street, Chupei City
 Hsinchu, Taiwan, R.O.C.
 Tel: (8863)5526789 Fax: (8863)5526611

Richtek Technology Corporation

Taipei Office (Marketing)
 5F, No. 95, Minchiuan Road, Hsintien City
 Taipei County, Taiwan, R.O.C.
 Tel: (8862)86672399 Fax: (8862)86672377
 Email: marketing@richtek.com

Information that is provided by Richtek Technology Corporation is believed to be accurate and reliable. Richtek reserves the right to make any change in circuit design, specification or other related things if necessary without notice at any time. No third party intellectual property infringement of the applications should be guaranteed by users when integrating Richtek products into any application. No legal responsibility for any said applications is assumed by Richtek.