

SMD MICROPROCESSOR CRYSTAL

ABLS6M



RoHS / RoHS II Compliant



6.0 x 3.0 x 1.9mm

Moisture Sensitivity Level (MSL) – This product is Hermetically Sealed and not Moisture Sensitive - MSL = N/A: Not Applicable

FEATURES:

- **Reduced footprint from ABLS (standard HC/49US package) by 66%**
- Low profile: 1.9mm typ. height
- Suitable for RoHS compliant reflow
- Tight stability & extended temperature options
- High reliability & Cost effective
- Resistance welded metal package

APPLICATIONS:

- Wireless Applications
- Home electronics
- Computers, modems, and communications
- Microprocessors

STANDARD SPECIFICATIONS:

Parameters	Minimum	Typical	Maximum	Units	Notes
Frequency Range*	12.0		30.0	MHz	
Standard Frequencies	12.0, 16.0			MHz	
Operation Mode	Fundamental (AT-cut)				
Operating Temperature	0		+70	°C	See options
Storage Temperature	-40		+125	°C	
Frequency Tolerance @+25°C	-50		+50	ppm	See options
Frequency Stability over the Operating Temperature (ref. to +25°C)	-50		+50	ppm	See options
Equivalent series resistance (R1)			60	Ω	@+25°C
Shunt capacitance (C0)			5	pF	
Load capacitance (CL)	18			pF	Standard (See options if other than STD)
Drive Level		50	100	μW	
Aging	-5		+5	ppm	@25°C±3°C First year
Insulation Resistance	500			MΩ	@ 100Vdc ± 15V
Drive level dependency (DLD)	10nw ~ 100uw, 12 points Change in ESR (Maximum - Minimum) over DLD range < 30% ESR max.				

* Please contact Abracon for other frequencies.

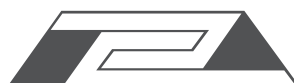

SMD MICROPROCESSOR CRYSTAL

ABLS6M

 RoHS / RoHS II Compliant



6.0 x 3.0 x 1.9mm

PART IDENTIFICATIONS: (Left blank if standard)

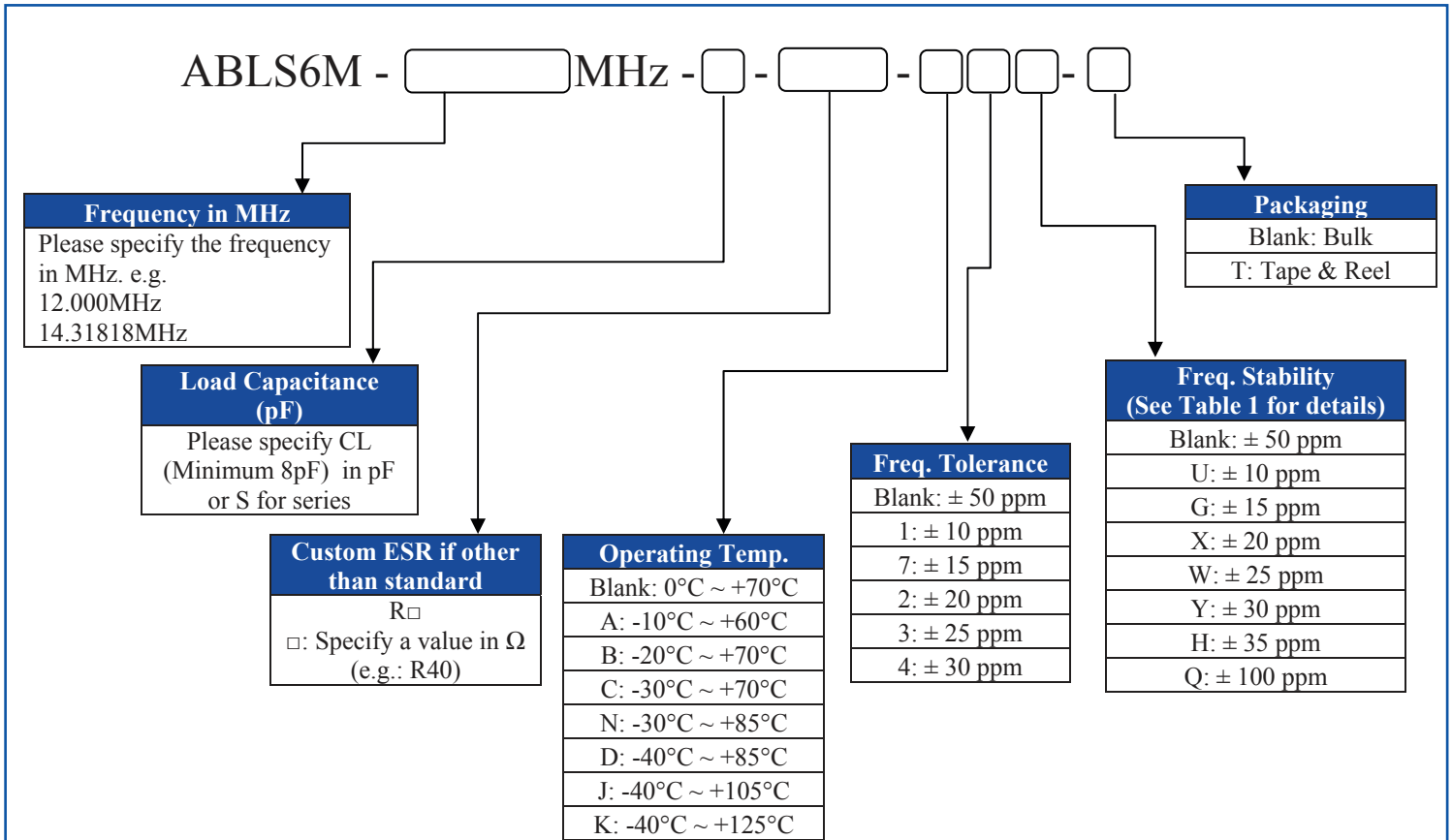

Table 1 Available Combinations of Operating Temp. and Freq. Stability

Operating Temp.	Freq. Stability							
	U:±10ppm	G:±15ppm	X:±20ppm	W:±25ppm	Y:±30ppm	H:±35ppm	Std.:±50ppm	Q:±100ppm
A: -10°C ~ +60°C	√	√	√	√	√	√	√	√
Std.: 0°C ~ +70°C	√	√	√	√	√	√	√	√
B: -20°C ~ +70°C		√	√	√	√	√	√	√
C: -30°C ~ +70°C			√	√	√	√	√	√
N: -30°C ~ +85°C					√	√	√	√
D: -40°C ~ +85°C					√	√	√	√
J: -40°C ~ +105°C							√	√
K: -40°C ~ +125°C								√

Note: Please contact Abracon for other frequency stability and operating temperature range options.



SMD MICROPROCESSOR CRYSTAL

ABLS6M



RoHS / RoHS II Compliant



6.0 x 3.0 x 1.9mm

OUTLINE DIMENSION:

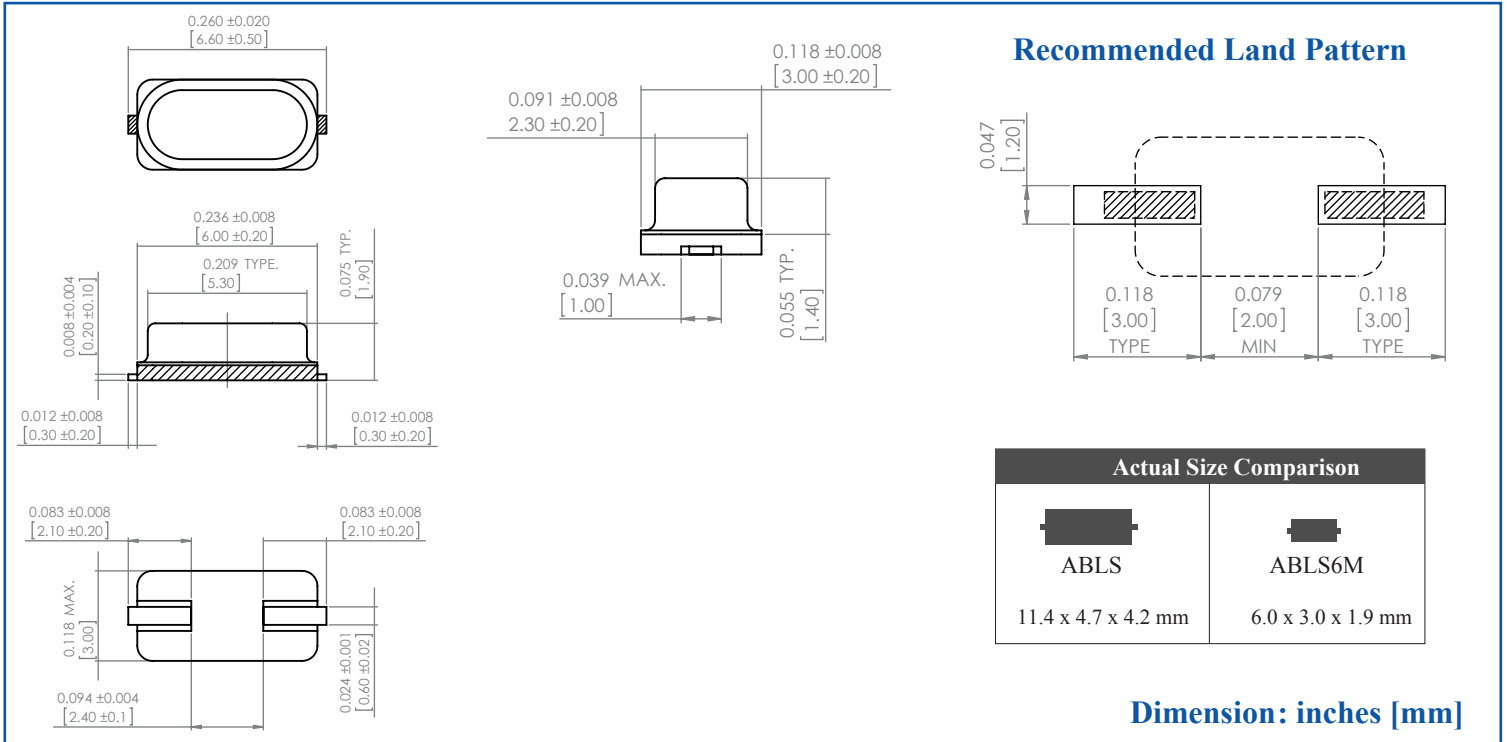

REFLOW PROFILE:

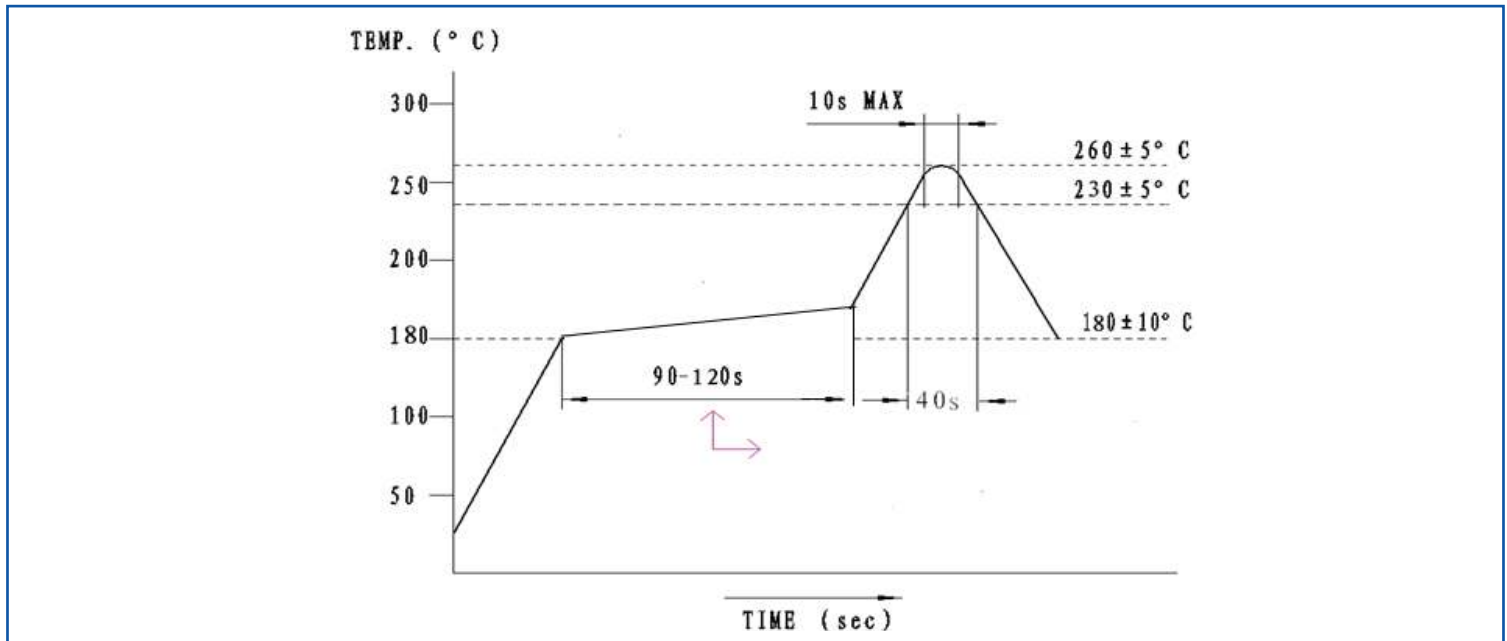

SMD MICROPROCESSOR CRYSTAL

ABLS6M



RoHS / RoHS II Compliant



6.0 x 3.0 x 1.9mm

TAPE & REEL:

T = tape and reel (3000pcs/reel)

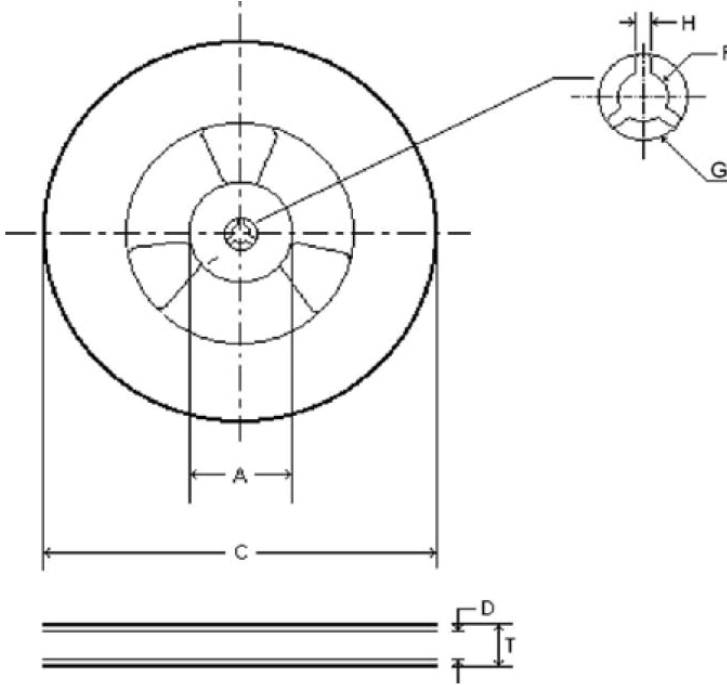

No.	Dimensions (mm)
A	100 ± 1.0
C	330 ± 2.0
D	16.4 ± 1.0
T	20.4 ± 0.5
F	13.0 ± 0.2
G	20.2 min.
H	1.5 min.

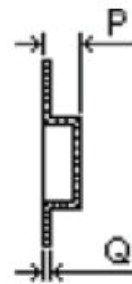
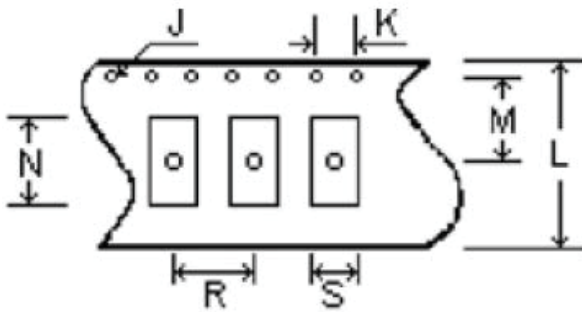

No.	Dimensions (mm)
J	Ø1.5
K	4.0 ± 0.1
L	16.0 ± 0.3
M	7.5 ± 0.1
N	8.8 ± 0.1
P	2.2 ± 0.1
Q	0.3 ± 0.05
R	8.0 ± 0.1
S	3.4 ± 0.1

Dimensions: mm

ATTENTION: Abracon Corporation's products are COTS – Commercial-Off-The-Shelf products; suitable for Commercial, Industrial and, where designated, Automotive Applications. Abracon's products are not specifically designed for Military, Aviation, Aerospace, Life-dependant Medical applications or any application requiring high reliability where component failure could result in loss of life and/or property. For applications requiring high reliability and/or presenting an extreme operating environment, written consent and authorization from Abracon Corporation is required. Please contact Abracon Corporation for more information.

ABRACON IS
ISO9001:2008
CERTIFIED



ABRACON
CORPORATION

2 Faraday, Suite# B | Irvine | CA 92618 **Revised: 01.29.15**

Ph. 949.546.8000 | Fax. 949.546.8001

Visit www.abracon.com for Terms and Conditions of Sale